

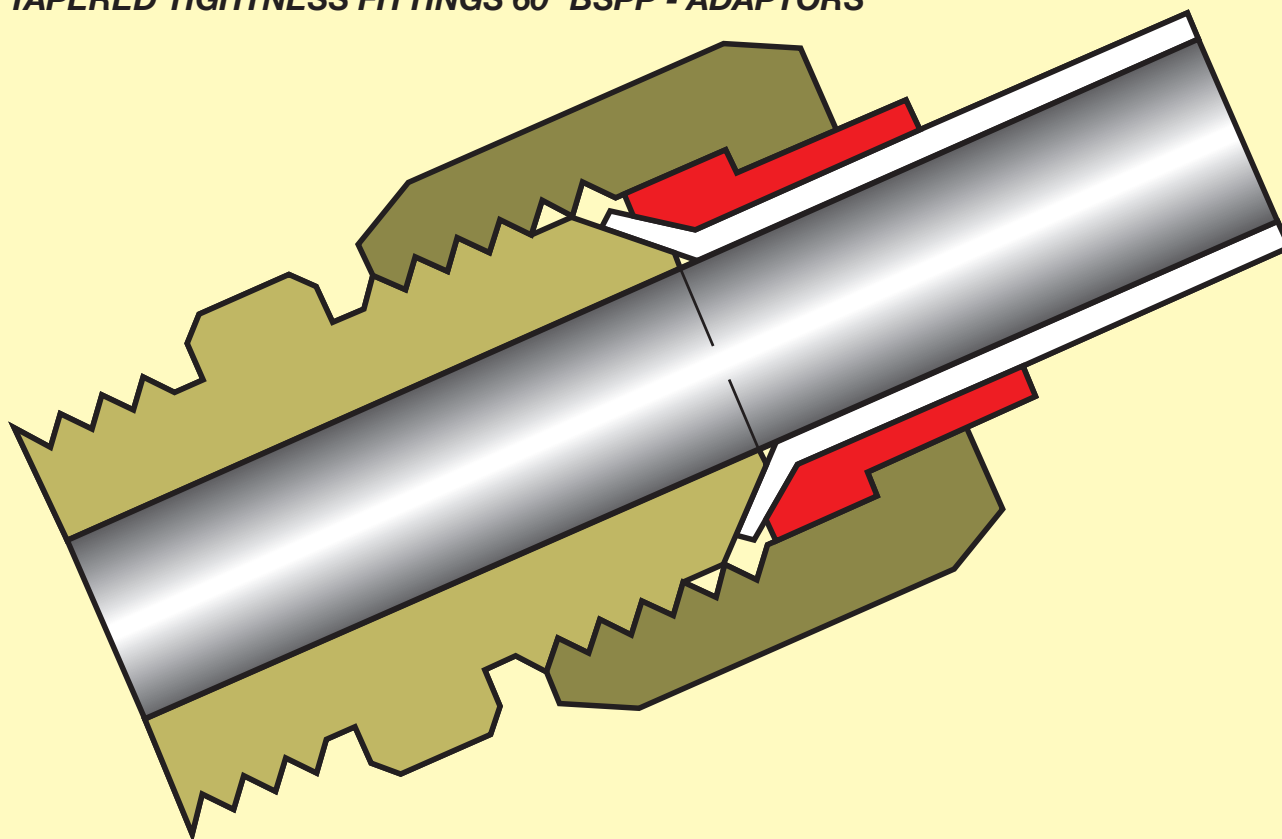

RACCORDI PER TUBI SVASATI - SAE J 514 - 37°
RACCORDI A TENUTA CONICA 60° BSPP - ADATTATORI
RACCORDS POUR TUBES EVASES - SAE J 514 - 37°
RACCORDS AVEC ETANCHEITE CONIQUE 60° BSPP - ADAPTATEURS
FITTINGS FOR FLARED TUBES - SAE J 514 - 37°
TAPERED TIGHTNESS FITTINGS 60° BSPP - ADAPTORS



37° ROHRVERSCHRAUBUNGEN FÜR BÖRDELROHR SAE J 514
DICHTKEGEL - VERSCHRAUBUNGEN 60° BSPP - ADAPTER
RACORES PARA TUBOS ABOCARDADOS - SAE J 514 - 37°
RACORES DE CIERRE CONICO 60° BSPP - ADAPTADORES



**RASTELLI
RACCORDI - s.r.l.**
27019 VILLANTERIO (PV) - ITALIA

Tel (+39) 0382.963000 r.a - 967257 - 967067 - Fax (+39) 0382.963210 - 967080
 e-mail: marketing.it@rastelliraccordi.it - web: www.rastelliraccordi.com
 e-mail: administration.it@rastelliraccordi.it

- TORINO
Corso traiano, 70/72
Tel. 011-611508/6197041
Telefax 011-6191106

- PADOVA
Via Navigazione Interna, 9
Tel. 049-7800933
Telefax 049-7800234

- BOLOGNA
Calderara di Reno
Loc. Bargellino
Via dell'Industria, 4/e
Tel. 051-728889/728886
Telefax 051-727486

- AVELLINO
S.Martino Valle Caudina
Strada Statale 7 - Km. 246
Tel. 0824-832714
Telefax 0824-832720

- D-73760
OSTFILDERN-NELLINGEN
Felix Wankel Str. 21
Tel. (+49) 711-3412086
Telefax (+49) 711-3412142

- 28000 CHARTRES-FRANCE
1 Pôle Atlantis
Téléphone: (+33) 2-37302466
Télécopie: (+33) 2-37907982

- 44335 NANTES-CEDEX 3
61, Rue de la Garde
Téléphone: (+33) 2-40521905
Télécopie: (+33) 2-40521961

- 08107 MARTORELLES
Barcelona (ESPANA)
C/can Fanosa n. 18
Poligono Industrial Roca
Téléphone: (+34) 93-5705895
Telefax: (+34) 93-5705954

- Rastelli raccordi Trading
(Nanjing) Co., Ltd.
Room 908, CFC Building A
#300 Zhongshan Est Road
Baixia District, Nanjing (CHINA)



ESECUZIONE:

ACCIAIO AL CARBONIO

- ACCIAIO INOX AISI 316L
(SU RICHIESTA)
-

FABRICATION:

ACIER AU CARBONE

- ACIER INOX AISI 316L
(SUR DEMANDE)
-

EXECUTION:

CARBON STEEL

- STAINLESS/STEEL AISI 316L
(ON REQUEST)
-

HERSTELLUNG:

KOHLNSTOFF STAHL

- EDELSTHAL AISI 316L
(AUF ANFRAGE)
-

CONSTRUCCION:

ACERO AL CARBONIO

- ACERO INOXIDABLE AISI 316L
(SOBRE DEMANDA)

- Gli articoli su fondo colorato sono disponibili su richiesta con consegna da pronta a 60 giorni. Prezzo: escluso dallo sconto massimo.
- Die Artikel auf buntem Hintergrund stehen zur Verfügung mit sofortiger bis 60-Tage Lieferzeit. Preis: ausgeschlossen vom Höchststrabatt.
- The articles on a coloured background are available on request with prompt to 60-days delivery. Price: excluded from maximum discount.
- Les articles sur fond coloré sont disponibles sur demande avec livraison d'immédiate jusqu'à 60 jours. Prix: exclus de l'escompte maximum.
- Los artículos sobre fondo en color están disponibles a petición con entrega de pronta hasta 60 días. Precio: excluidos del descuento máximo.



**CERTIFICAZIONI DI QUALITA'
QUALITÄTSZERTIFIKATE
QUALITY CERTIFICATES
CERTIFICATION DE QUALITE
CERTIFICACIÓN DE CALIDAD**



RINA
www.rina.org

– CERTIFICATO	N° 95/94/S
– ZERTIFIKATE	N° 95/94/S
– CERTIFICATE	N° 95/94/S
– CERTIFICATION	N° 95/94/S
– CERTIFICADO	N° 95/94/S



– CERTIFICATO	N° IT 2633
– ZERTIFIKATE	N° IT 2633
– CERTIFICATE	N° IT 2633
– CERTIFICATION	N° IT 2633
– CERTIFICADO	N° IT 2633





**I NOSTRI INDIRIZZI - UNSERE ADRESSE - OUR ADRESSES
NOS ADRESSES - NUESTRAS SEÑAS**

**SEDE CENTRALE - HAUPTSITZ - HEAD OFFICE
SIEGE CENTRAL - SEDE CENTRAL**

Rastelli Raccordi - s.r.l.
27019 VILLANTERIO (PV) - ITALIA
Tel. (+39) 0382 / 963000 r.a. - 967257 - 967067
Fax: (+39) 0382 / 967080 - 963210
e-mail: marketing.it@rastelliraccordi.com
administration.it@rastelliraccordi.com
sito intrnet: www.rastelliraccordi.it

Organizzazione di vendita in Italia
Verkaufsorganisation in Italien
Sales organization in Italy
Organisation des ventes en Italie
Organización de ventas en Italia

RIT - TORINO
Corso Traiano, 70/72
Tel. 011-611508 / 6197041 - Fax 011-6191106
e-mail: torino.it@rastelliraccordi.it

RIT - PADOVA
Via Navigazione Interna, 9
Tel. 049-7800933 - Fax 049-7800234
e-mail: padova.it@rastelliraccordi.it

RIT - BOLOGNA
Calderara di Reno - Loc. Bargellino
Via dell'Industria, 4/e
Tel. 051-728889 / 728886 - Fax 051-727486
e-mail: bologna.it@rastelliraccordi.it

RIT - AVELLINO
S. Martino Valle Caudina
Strada Statale 7 - Km. 246
Tel. 0824 / 832714 - Fax 0824 / 832720
e-mail: avellino.it@rastelliraccordi.it

Organizzazione di vendita in Europa
Verkaufsorganisation in Europa
Sales organization in Europe
Organisation des ventes en Europe
Organización de ventas en Europa

D-73760 OSTFILDERN-NELLINGEN
Felix Wankel Str. 21
Tel. (+49) 711-3412086 - Fax (+49) 711-3412142
e-mail: germany@rastelliraccordi.eu

28000 CHARTRES-FRANCE
1, Pôle Atlantis
Téléphone: (+33) 2-37302466
Télécopie: (+33) 2-37907982
e-mail: france1@rastelliraccordi.eu
france2@rastelliraccordi.eu

44335 NANTES-CEDEX 3
61, Rue de la Garde - BP93509
Téléphone: (+33) 2-40521905
Télécopie: (+33) 2-40521961
e-mail: nantes@rastelliraccordi.eu

08107 MARTORELLES Barcelona (ESPAÑA)
C/Can Fanosa n. 18
Poligono Industrial Roca
Teléfono (+34) 93-5705895 -
Telefax (+34) 93-5705954
e-mail: espana@rastelliraccordi.eu

Organizzazione di vendita nel Mondo
Verkaufsorganisation in der Welt
Sales organization in the World
Organisation des ventes dans le Monde
Organización de ventas en el Mundo

Rastelli Raccordi Trading
(Nanjing) Co., Ltd.
Room 908 , CFC Building A
#300 Zhongshan East Road - Baixia District, Nanjing (CHINA)
email: yanhua.wu@rastelliraccordi.it

- CATALOGO:** RACCORDI PER TUBI SVASATI - SAE J 514 - 37°
RACCORDI A TENUTA CONICA 60° BSPP - ADATTATORI
- CATALOGUE:** RACCORDS POUR TUBES EVASES - SAE J 514 - 37°
RACCORDS AVEC ETANCHEITE CONIQUE 60° BSPP - ADAPTATEURS
- CATALOGUE:** FITTINGS FOR FLARED TUBES - SAE J 514 - 37°
TAPERED TIGHTNESS FITTINGS 60° BSPP - ADAPTORS
- KATALOG:** 37° ROHRVERSCHRAUBUNGEN FÜR BÖRDELROHR SAE J 514
DICHTKEGEL VERSCHRAUBUNGEN 60° BSPP - ADAPTER
- CATÁLOGO:** RACORES PARA TUBOS ABOCARDADOS - SAE J 514 - 37°
RACORES DE CIERRE CONICO 60° BSPP - ADAPTADORES



RACCORDI PER ALTA PRESSIONE TIPO SAE

Grazie alle sue particolari caratteristiche, il raccordo SAE J 514 - 37° per condutture in tubi d'acciaio laminato senza saldatura garantisce un montaggio meccanico altamente sicuro.

- Il raccordo per tubi svasati a 37° è composto da tre parti: corpo raccordo, dado e bussola.
 - Il terminale svasato del tubo è bloccato fra due superfici coniche: cono del corpo e bussola. La tenuta è realizzata senza alcuna deformazione di nessun particolare ma solo in modo meccanico.
 - La bussola è autocentrante, essendo caratterizzata da un gioco fra il dado e il tubo, garantisce allineamento corretto fra svasatura bussola e cono del corpo. Viene quindi utilizzata come anello di bloccaggio e supporto del tubo.
 - La pressione di scoppio del raccordo è di gran lunga superiore rispetto a quella del tubo a cui viene collegato.
- Questa caratteristica offre una maggiore garanzia di sicurezza.

APPROVAZIONI

- Norma A.S.M.E.: il raccordo SAE J 514 - 37° soddisfa le specifiche stabilite da A.S.M.E. relative ai tubi ad alta pressione.
- S.A.E. J 514: il raccordo SAE J 514 - 37° soddisfa le normative pubblicate nello standard S.A.E. relativo ai raccordi idraulici.
- Militar Standard da MS 51500 a MS 51534: il raccordo SAE J 514 - 37° soddisfa le specifiche relative ai raccordi svasati a 37° in acciaio al carbonio o in acciaio inossidabile.

RACCORDS POUR HAUTE PRESSION TYPE SAE

Par ses caractéristiques spéciales, le raccord SAE J 514 - 37° pour conduites en acier laminé sans soudures garantit un montage mécanique de haute sécurité.

- Le raccord pour tubes évasés à 37° se compose de trois parties: corps du raccord, écrou et fourreau.
 - L'embout évasé du tube est bloqué entre deux surfaces coniques: cône du corps et fourreau.
- Le joint est fait mécaniquement sans aucune déformation d'élément.
- La fourreau est autocentrante par une possibilité de jeu entre l'écrou et le tube, ce qui garantit un alignement correct entre évasement de la fourreau et cône du corps, et fait fonction dans ce cas d'anneau de blocage et de support du tube.
 - La pression d'éclatement du raccord est très loin supérieure à celle du tube auquel celui-ci est relié.
- Cette caractéristique offre une plus grande sécurité.

APPROBATIONS

- Normes A.S.M.E.: le raccord SAE J 514 - 37° satisfait les règles établies par A.S.M.E. relatives aux tubes à hautes pressions.
- S.A.E. J 514; le raccord SAE J 514 - 37° satisfait les règles publiées dans le standard S.A.E. relatives aux raccords hydrauliques.
- Militar standard de MS 51500 à MS 51534: le raccord SAE J 514 - 37° satisfait aux règles relatives aux raccords évasés à 37° en acier au carbone ou acier inoxydable.

SAE-TYPE HIGH PRESSURE FITTINGS

The particular features of the SAE J 514 - 37° fitting for ducts consisting of weldless, rolled-steel pipes guarantee a very level of mechanical assembly safety.

- The fitting for pipes flared at 37° consists of three parts: fitting body nut and bush.
 - The flared end of the pipes is held between two coneshaped surfaces: body cone and bush. The seal is simply formed by means of a mechanical operation without any part being deformed.
 - The bush is self-centring with a degree of clearance between the nut and the pipe which ensures the correct alignment between the bush flare and the body cone and is therefore used as a ring to hold and support the pipe.
 - The fitting's bursting pressure is far higher than that of the pipe it is connected to.
- This feature gives a greater guarantee of safety.

APPROVALS

- A.S.M.E. standard: the SAE J 514 - 37° fitting conforms with the specification laid down by A.S.M.E. for high-pressure pipes.
- S.A.E. J 514: the SAE J 514 - 37° fitting conforms with the provisions published in the S.A.E. standard for hydraulic fittings.
- Militar Standards from MS 51500 to MS 51534: the SAE J 514 - 37° fitting conforms with specifications for 37° flared fittings made of carbon steel or stainless steel.

HOCHDRUCKVERSCHRAUBUNGEN TYP SAE

Die 37° Verschraubung SAE J 514 für Rohrleitungen aus Walzstahl ohne Schweißstellen garantiert dank ihrer besonderen Merkmale eine mechanische Montage von hoher Sicherheit.

- Die Verschraubung für Rohrleitungen mit einer Bördelung von 37° besteht aus drei Teilen: Verschraubungskörper, Überwurfmutter und Stützhülse.
 - Das gebördelte Endstück der Rohrleitung ist zwischen zwei kegelförmigen Oberflächen eingespannt. Die Spannung ist deformationslos und ausschließlich mechanisch.
 - Die Stützhülse ist selbstzentrierend. Ihr Spiel zwischen der Überwurfmutter und der Rohrleitung bewirkt eine perfekte Ausrichtung zwischen der Stützhülse und dem Konus des Körpers, wodurch die Stützhülse als Sperring und Rohrlagerung dient.
 - Der Platzdruck der Verschraubung ist weitaus höher als der des Rohrs, mit dem sie verbunden wird.
- Diese Eigenschaft bietet eine höhere Sicherheitsgarantie.

ZULASSUNGEN

- A.S.M.E.-Norm: die 37° Verschraubung SAE J 514 erfüllt die A.S.M.E.-Vorgaben für Hochdruckrohrleitungen.
- SAE J 514: die 37° Verschraubung SAE J 514 entspricht den Vorschriften, die im SAE-Standard für Verschraubungen für Wasserrohrleitungen angegeben sind.
- Militar Standard MS 51500 bis MS 51534: Die Verschraubung SAE J 514 erfüllt die Vorschriften für 37°-Bördelverschraubungen aus Kohlenstoffstahl oder aus rostfreiem Stahl.

RACORERIA PARA ALTA PRESIÓN TIPO SAE

El racor SAE J 514 - 37° destinado a conducciones en tubería de acero estirado sin soldadura, dadas sus características intrínsecas, garantiza una alta seguridad de montaje mecánico:

- Racor para tubería abocardada de asiento cónico a 37°; el cual se compone de tres piezas: tuerca, férula y cuerpo.
- El tubo es presionado sobre su espesor entre la superficie del cuerpo del racor y la de la férula.
- El anclaje y la estanqueidad se obtienen mecánicamente, sin que por ello la pieza sufra deformación alguna.
- La férula es usada como soporte de la tubería, al mismo tiempo que protege a ésta. La férula es auto-centrante; existe un juego entre ésta y la tuerca, que permite la correcta alineación de la férula aunque el tubo presente un ligero defecto de alineación axial o angular.
- La presión de estallido del racor es muy superior a la presión de estallido del tubo al cual va destinado, característica que ofrece una mayor seguridad y garantía.

NORMALIZACIÓN

- Norma A.S.M.E.: las especificaciones definidas por el A.S.M.E. para tubos de alta presión son cumplidas por el racordaje SAE J 514 - 37°.
- S.A.E. J 514: el racor SAE J 514 - 37° cumple la normalización que se publica en el standard S.A.E. sobre racores hidráulicos.
- Militar Standard MS 51500 a MS 51534: las especificaciones sobre racores abocardados a 37° fabricados en acero al carbono o en acero inoxidable se cumplen también en el racordaje SAE J 514 - 37°.



MATERIALE

I raccordi SAE J 514 - 37° vengono costruiti da corpi forgiati o da barre in acciaio conformi alle seguenti specifiche:

SPECIFICHE	ITALIANE	TEDESCHE	FRANCESI	INGLESI	AMERICANE
Bussole ricavate da barre	UNI EN 10277 11S Mn Pb 37	DIN W-Nr. 1.0737	AFNOR S 300 Pb	- -	ASTM A 108 C 1137
Dadi stampati	-	DIN W-Nr. 1.0214/1.0502	AFNOR CC 45	- -	ASTM A 576 C 1110
Dadi ricavati da barre	UNI EN 10277 11S Mn Pb 37	DIN W-Nr. 1.0737	AFNOR S 300 Pb	BS 970 PTI 220 Mo 7 Pb	ASTM A 108 12 L14
Corpi ricavati da barre	UNI EN 10277 11S Mn Pb 37	DIN W-Nr. 1.0737	AFNOR S 300 Pb	BS 970 PTI 220 Mo 7 Pb	ASTM A 108 12 L14
Corpi forgiati	UNI 4838 CF 9S Mn 28	DIN W-Nr. 1.0715	AFNOR S200	BS 970 PTI 220 Mo 7	ASTM A 576 12 L14

- PROTEZIONE: trattamento di passivazione BIANCA Fe/Zn 8-UNI ISO 2081 con cromo trivalente (esente da cromo esavalente) con SIGILLANTE in ottemperanza alla NORMATIVA EUROPEA 200/53 CE.

DIMENSIONI DELLA FILETTATURA:

- A) Misura raccordo per tubo in pollici: 8=DIMENSIONE JIC=1/2" (NPTF-BSPT-BSPP).
B) Misura raccordo per tubo in millimetri: 1/2" (NPTF-BSPT-BSPP) 3/4-16" (UNF 2A) M16 (Metrico).

DIAMETRO ESTERNO DEL TUBO:

- A) Misura raccordo per tubo in pollici: 8=DIMENSIONE JIC=DIAMETRO EST. 1/2".
B) Misura raccordo per tubo in millimetri: 12=TUBO DIAM. EST. 12 mm.

MATERIEUX

Les raccords SAEJ514.37° sont construits en corps forgés ou en barres acier conformes aux normes ci-dessous:

DESIGNATIONS	ITALIENNES	ALLEMANDES	FRANCAISES	ANGLAISES	AMERICAINES
Forreaux pirs dans les barres	UNI EN 10277 11S Mn Pb 37	DIN W-Nr. 1.0737	AFNOR S 300 Pb	- -	ASTM A 108 C1137
Ecrous moulés	-	DIN W-Nr. 1.0214/1.0502	AFNOR CC 45	- -	ASTM A 576 C1110
Ecrous pris dans des barres	UNI EN 10277 11S Mn Pb 37	DIN W-Nr. 1.0737	AFNOR S 300 Pb	BS 970 PTI 220 Mo 7 Pb	ASTM A 108 12 L14
Corps pris dans des barres	UNI EN 10277 11S Mn Pb 37	DIN W-Nr. 1.0737	AFNOR S 300 Pb	BS 970 PTI 220 Mo 7 Pb	ASTMA 108 12 L14
Corps forgés	UNI 4838 CF 9S Mn 28	DIN W-Nr. 1.0715	AFNOR S200	BS 970 PTI 220 Mo 7	ASTM A 576 12 L 14

- PROTECTION: traitement ZINGUAGE BLANC Fe/Zn 8-UNI ISO 2081 avec chrome trivalent (exempt de chrome hexavalent) avec fixateur selon la NORME EUROPÉENNE 200/53 CE.

DIMENSIONS DU FILETAGE:

- A) Mesure raccord pour tubes en pouces: 8=DIMENSIONE JIC=1/2" (NPTF-BSPT-BSPP).
B) Mesure raccord pour tubes en millimètres: 1/2" (NPTF-BSPT-BSPP) 3/4-16" (UNF 2A) M16 (Metricque).

DIAMETRE EXTERNE DU TUBE:

- A) Mesure raccord pour tube en pouces: 8=DIMENSIONE JIC= DIAMETRE EXT. 1/2".
B) Mesure raccord pour tubes en millimètres: 12=TUBES DIAMETRE EXT. 12 mm.



MATERIAL

SAE J 514 - 37° fittings are made of forged body or steel bars conforming with the following specification

SPECIFICATION	ITALIAN	GERMAN	FRENCH	ENGLISH	AMERICAN
Bushed made from bars	UNI EN 10277 11S Mn Pb 37	DIN W-Nr. 1.0737	AFNOR S 300 Pb	- -	ASTM A 108 C 1137
Pressed nuts	-	DIN W-Nr. 1.0214/1.0502	AFNOR CC 45	- -	ASTM A 576 C 1110
Nuts made from bars	UNI EN 10277 11S Mn Pb 37	DIN W-Nr. 1.0737	AFNOR S 300 Pb	BS 970 PTI 220 Mo 7 Pb	ASTM A 108 12 L14
Bodies made from bars	UNI EN 10277 11S Mn Pb 37	DIN W-Nr. 1.0737	AFNOR S 300 Pb	BS 970 PTI 220 Mo 7 Pb	ASTM A 108 12 L14
Forged Bodies	UNI 4838 CF 9S Mn 28	DIN W-Nr. 1.0715	AFNOR S 200	BS 970 PTI 220 Mo 7	ASTM A 576 C 12 L14

- PROTECTION: white passivation treatment Fe/Zn 8-UNI ISO 2081 with trivalent Chrome (free from hexavalent chrome) with sealer in compliance with the European Norm EC 200/53.

THREAD DIMENSIONS:

- A) Pipe fitting measurement in inches: 8=DIMENSION JIC=1/2" (NPTF-BSPT-BSPP).
B) Pipe fitting measurement in millimetres: 1/2" (NPTF-BSPT-BSPP) 3/4-16" (UNF 2A) M16 (Metric).

OUTSIDE PIPE DIAMETER:

- A) Pipe fitting measurement in inches: 8=DIMENSION JIC=OUTSIDE PIPE DIAMETER 1/2".
B) Pipe fitting measurement in millimetres:12=OUTSIDE PIPE DIAMETER 12 mm.

MATERIAL

Die 37° Verschraubungen SAE J 514 werden aus Schmiedestücken Oder Stahlstangen nach den folgenden Spezifikationen gearbeitet

SPEZIFIKATIONEN	ITALIENISCHE	DEUTSCHE	FRANZÖSISCHE	ENGLISCHE	AMERIKANISCHE
Aus Stangen gearbeitete Buchsen	UNI EN 10277 11S Mn Pb 37	DIN W-Nr. 1.0737	AFNOR S 300 Pb	- -	ASTM A 108 C 1137
Kaitgeschlagene Schraubenmuttern	-	DIN W-Nr. 1.0214/1.0502	AFNOR CC 45	- -	ASTM A 576 C 1110
Aus Stangen gearbeitete Schraubenmuttern	UNI EN 10277 11S Mn Pb 37	DIN W-Nr. 1.0737	AFNOR S 300 Pb	BS 970 PTI 220 Mo 7 Pb	ASTM A 108 12 L 14
Aus Stangen gearbeitete Körper	UNI EN 10277 11S Mn Pb 37	DIN W-Nr. 1.0737	AFNOR S 300 Pb	BS 970 PTI 220 Mo 7 Pb	ASTM A 108 12 L 14
Schmiedestücke	UNI 4838 CF 9S Mn 28	DIN W-Nr. 1.0715	AFNOR S 200	BS 970 PTI 220 Mo 7	ASTM A 576 C 12 L 14

- OBERFLÄCHENSCHUTZ: behandlung von weißer Passivierung Fe/Zn 8-UNI ISO 2081 mit DREIWEITIGEM CHROM (frei von sechswertigem Chrom) mit Dichtungsmasse gemäß der Europäischen Norm EG 200/53.

GEWINDEGRÖSSEN:

- A) Größe des Rohranschlusses in Zoll: C=GRÖSSE JIC=1/2" (NPTF-BSPT-BSPP).
B) Größe des Rohranschlusses in mm: 1/2"(NPTF-BSPT-BSPP) 3/4-16" (UNF 2A) M16 (Metrisch).

AUSSENDURCHMESSER DES ROHRES:

- A) Größe des Rohranschlusses in Zoll: C=GRÖSSE JIC=AUSSENDURCHMESSER 1/2".
B) Größe des Rohranschlusses in mm:12=ROHR Außendurchmesser 12 mm.

EL MATERIAL

Los racores SAE J 514 - 37° han sido fabricados en acero a partir de pieza forjada o de barra de acuerdo con las siguientes especificaciones

ESPECIFICACIONES	ITALIANAS	ALEMANAS	FRANCESAS	INGLESAS	AMERICANAS
Férulas sacadas de barra	UNI EN 10277 11SMnPb 37	DIN W-Nr. 1.0737	AFNOR S 300 Pb	- -	ASTM A 108 C 1137
Tuercas forjadas	-	DIN W-Nr. 1.0214/1.0502	AFNOR CC 45	- -	ASTM A 576 C 1110
Tuercas sacadas de barras	UNI EN 10277 11S Mn Pb 37	DIN W-Nr. 1.0737	AFNOR S 300 Pb	BS 970 PTI 220 Mo 7 Pb	ASTM A 108 12 L14
Piezas rectas	UNI EN 10277 11S Mn Pb 37	DIN W-Nr. 1.0737	AFNOR S 300 Pb	BS 970 PTI 220 Mo 7 Pb	ASTM A 108 12 L14
Piezas de forma	UNI 4838 CF 9S Mn 28	DIN W-Nr. 1.0715	AFNOR S 200	BS 970 PTI 220 Mo 7	ASTM A 576 C 12 L14

- PROTECCIÓN: tratamiento de PASIVACION BLANCA Fe/Zn 8 UNI ISO 2081 con CROMO TRIVALENTE (libre de cromo hexavalente) con silicona selladora conforme a la NORMATIVA EUROPEA 200/53 CE.

DIMENSIONES DE LA ROSCA:

- A) Designación racor para tubo en pulgadas: 8=MÓDULO JIC=1/2" (NPTF-BSPT-BSPP).
B) Designación racor para tubo milimétrico: 1/2" (NPTF-BSPT-BSPP) 3/4-16" (UNF 2A) M16 (Métrico).

DIÁMETRO EXTERIOR DEL TUBO:

- A) Designación racor para tubo en pulgadas: 8=MÓDULO JIC=PARA Ø EXT. 1/2".
B) Designación racor para tubo milimétrico:12=TUBO Ø EXT. 12 mm.



MONTAGGIO DEL RACCORDO 37° S.A.E.

1. - Porre la parte svasata del tubo sul cono del corpo e della bussola regolandola manualmente.
2. - Stringere con la chiave in modo da ottenere un'unione metallo/metallo completamente stagna (vedere tabella).

COPPIA DI SERRAGGIO			
Diam. tubo mm.	Diam. tubo pollici	Coppia min. Nm	Coppia max. Nm
6	1/4"	10	15
8	5/16"	15	23
10	3/8"	22	34
12	1/2"	31	47
14	-	41	63
15	-	46	70
16	5/8"	51	78
18	-	63	98
20	3/4"	75	118
25	1"	117	176
30	-	157	245
32	1" 1/4	176	274
38	1" 1/2	216	343

3. - Una caratteristica fondamentale del raccordo 37° SAE è la garanzia di un facile e veloce montaggio. Può, infatti, essere montato e smontato più volte grazie alla sua chiusura che rimane sempre a tenuta stagna ed ermetica.

SVASATURA CORRETTA

Una svasatura eseguita correttamente garantisce una durata più lunga e soddisfacente anche in prolungate condizioni critiche di utilizzo. Il diametro esterno massimo della svasatura deve essere uguale a quello esterno della bussola, mentre il diametro minimo deve essere uguale al diametro massimo della bussola.

ESEMPI

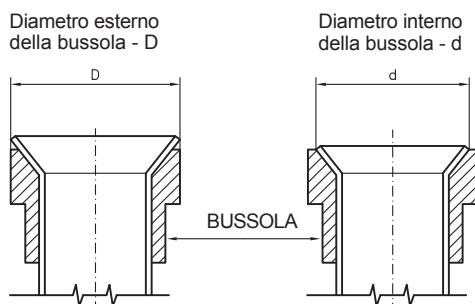

Diam. est. mm	Diam. (min) mm	Diam. (max) mm
6	8	9,7
8	9,5	11,3
10	11,2	12,7
12	14,9	17,3
14	17,9	20,2
15	17,9	20,2
16	17,9	20,2
18	22,3	24,7
20	22,3	24,7
25	28,7	31
30	35,8	38,9
32	35,8	38,9
38	41,4	45,3

MONTAGE DU RACCORD 37° S.A.E.

1. - Placer la partie évasée du tube sur le cône du corps et de la fourreau en réglant celle-ci manuellement.
2. - Serrer à l'aide de la clé de manière à obtenir un ensemble métal/métal complètement étanche (voir table).

COUPLE DE SERRAGE			
Diam. tube mm.	Diam. tube pouces	Couple min. Nm	Couple max. Nm
6	1/4"	10	15
8	5/16"	15	23
10	3/8"	22	34
12	1/2"	31	47
14	-	41	63
15	-	46	70
16	5/8"	51	78
18	-	63	98
20	3/4"	75	118
25	1"	117	176
30	-	157	245
32	1" 1/4	176	274
38	1" 1/2	216	343

3. - Une caractéristique fondamentale du raccord 37° SAE est la garantie d'un montage rapide et facile. Il peut, en effet, être monté et démonté plusieurs fois grâce à sa fermeture qui reste toujours étanche et hermétique.

EVASEMENT CORRECT

Un evasement correct garantit une durée plus longue et satisfaisante même en conditions critiques d'utilisation prolongées. Le diamètre extérieur maximum de l'évasement doit être égal au diamètre externe du fourreau alors que le diamètre minimum doit être égal au diamètre interne maximum de celui-ci.

ESEMPLI

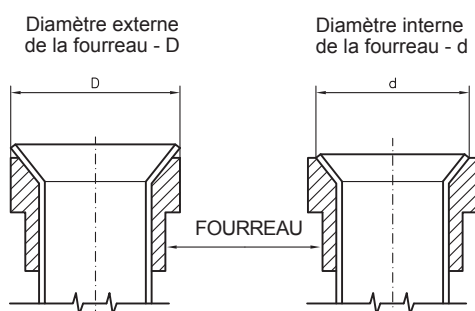

Diam. est. mm	Diam. (min) mm	Diam. (max) mm
6	8	9,7
8	9,5	11,3
10	11,2	12,7
12	14,9	17,3
14	17,9	20,2
15	17,9	20,2
16	17,9	20,2
18	22,3	24,7
20	22,3	24,7
25	28,7	31
30	35,8	38,9
32	35,8	38,9
38	41,4	45,3



S.A.E. 37° FITTING ASSEMBLY

1. - Place the flared part of the pipe on the body/bush cone and adjust manually.
2. - Tighten with the wrench so as to get a totally enclosed metal/metal joint (see table).

TORQUE WRENCH SETTINGS			
Pipe diameter mm.	Pipe diameter inches	Min. torque Nm	Max. torque Nm
6	1/4"	10	15
8	5/16"	15	23
10	3/8"	22	34
12	1/2"	31	47
14	-	41	63
15	-	46	70
16	5/8"	51	78
18	-	63	98
20	3/4"	75	118
25	1"	117	176
30	-	157	245
32	1" 1/4	176	274
38	1" 1/2	216	343

3. - A fundamental feature of the SAE 37° fitting is that it is easy and quick to assemble. It can in fact be assembled and removed on different occasions because of its enclosure which remains water and airtight at all times.

CORRECT FLARING

Flaring which has been done properly guarantees a longer and more satisfactory life even when subject to critical conditions over extended periods. The maximum outside flaring diameter must be the same as the outside bush diameter, while the minimum diameter must be the same as the bush's maximum inside diameter.

EXAMPLES

Out bush diameter - D

Inside bush diameter - d

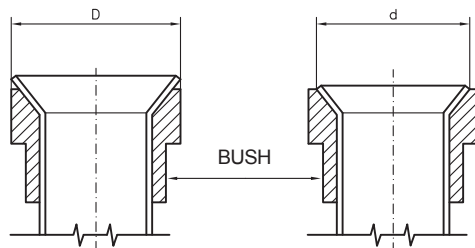

Out Diam. mm	(min) Diam. mm	(max) Diam. mm
6	8	9,7
8	9,5	11,3
10	11,2	12,7
12	14,9	17,3
14	17,9	20,2
15	17,9	20,2
16	17,9	20,2
18	22,3	24,7
20	22,3	24,7
25	28,7	31
30	35,8	38,9
32	35,8	38,9
38	41,4	45,3

MONTAGE DER 37° SAE-Verschraubung

1. - Das gebördelte Teil des Rohres auf den Konus des Körpers und der Stützhülse aufsetzen und manuell ausrichten.
2. - Mit dem Schlüssel festziehen, so daß eine vollkommen dichte Metall/Metall-Verbindung entsteht (siehe Tabelle).

ANZUGSMOMENT			
Rohrdurchm. in mm.	Rohrdurchm. in Zoll	Min. Anzugsmom. Nm	Max. Anzugsmom. Nm
6	1/4"	10	15
8	5/16"	15	23
10	3/8"	22	34
12	1/2"	31	47
14	-	41	63
15	-	46	70
16	5/8"	51	78
18	-	63	98
20	3/4"	75	118
25	1"	117	176
30	-	157	245
32	1" 1/4	176	274
38	1" 1/2	216	343

3. - Das 37° SAE-Stück garantiert grundsätzlich eine einfache und schnelle Montage. Es kann mehrmals dank seines Verschlusses, der immer dicht und hermetisch ist, montiert und demontiert werden.

KORREKTE BÖRDELUNG

Eine korrekt ausgeführte Bördelung garantiert eine längere Lebensdauer und zufriedenstellende Leistungen auch bei längerem Einsatz unter kritischen Bedingungen. Der maximale Außendurchmesser muß gleich dem Außendurchmesser der Stützhülse sein, während der minimale Durchmesser gleich dem maximalen Innendurchmesser der Stützhülse sein muß.

BEISPIELE

Aussendurchmesser der Stützhülse - D

Innendurchmesser der Stützhülse - d

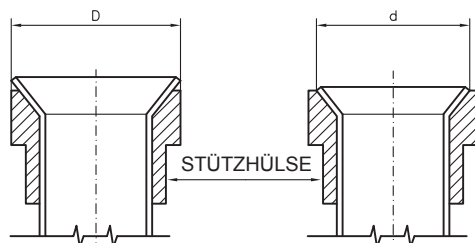

Auss Durchm mm	(min) Durchm mm	(max) Durchm mm
6	8	9,7
8	9,5	11,3
10	11,2	12,7
12	14,9	17,3
14	17,9	20,2
15	17,9	20,2
16	17,9	20,2
18	22,3	24,7
20	22,3	24,7
25	28,7	31
30	35,8	38,9
32	35,8	38,9
38	41,4	45,3



MONTAJE DEL RACOR 37° S.A.E.

- Colocar la parte abocardada con el cono, ajustando éste con la mano.
- Apretar con la llave para obtener una unión metal sobre metal totalmente estanca (ver tabla).

PAR DE APRIETE			
Ø tubo mm.	Ø tubo pulg	Par Min. Nm	Par Max. Nm
6	1/4"	10	15
8	5/16"	15	23
10	3/8"	22	34
12	1/2"	31	47
14	-	41	63
15	-	46	70
16	5/8"	51	78
18	-	63	98
20	3/4"	75	118
25	1"	117	176
30	-	157	245
32	1" 1/4	176	274
38	1" 1/2	216	343

3. - Característica básica del racor 37° SAE es el hecho de que garantiza un fácil y rápido montaje, pudiendo ser montado y desmontado numerosas veces, siendo su cierre siempre estanco y hermético.

ABOCARDADO CORRECTO:

Un abocardado correctamente ejecutado ofrecerá un servicio más largo y satisfactorio, incluso en condiciones de empleo permanentemente críticas. El diámetro exterior máximo del abocardado ha de ser igual al diámetro exterior de la férula. El diámetro mínimo del abocardado debe ser igual al diámetro interior máximo de la férula.

EJEMPLOS

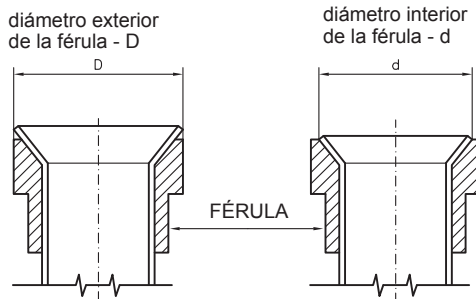

Ø exterior mm	d (míni) mm	D (máxi) mm
6	8	9,7
8	9,5	11,3
10	11,2	12,7
12	14,9	17,3
14	17,9	20,2
15	17,9	20,2
16	17,9	20,2
18	22,3	24,7
20	22,3	24,7
25	28,7	31
30	35,8	38,9
32	35,8	38,9
38	41,4	45,3

In caso di svasatura del tubo troppo corta, quasi tutta la superficie di contatto del raccordo non verrà utilizzata. Sussiste, pertanto, il rischio che la superficie del tubo venga schiacciata a causa della superficie di contatto insufficiente. In questi casi, non viene garantita la sicurezza massima contro perdite o rotture della svasatura. In caso di svasatura del tubo troppo lunga, si verificheranno problemi con la filettatura del dado che rimarrà bloccato impedendo così il corretto montaggio del raccordo. Per garantire un funzionamento ottimale, la svasatura deve essere perpendicolare e concentrica al tubo e alla bussola. Difetti relativi alla perpendicolarità e alla concentricità possono essere causati da taglio errato del tubo o da una formazione irregolare provocata da un utensile da taglio o da una svasatura difettosa. Quando si deve tagliare il tubo bisogna prendere in considerazione un certo valore che deve venire successivamente sommato alla lunghezza della linea. Per determinare tale lunghezza è necessario aggiungere alla lunghezza desiderata del tubo una lunghezza "L" che rappresenta la parte del cono del raccordo che entra nella parte svasata del tubo. Inoltre, ogni svasatura richiede una lunghezza di tubo compreso fra 0,5 e 1 mm; a seconda dello spessore del tubo stesso. Consultare la tabella relativa alla lunghezza "L".

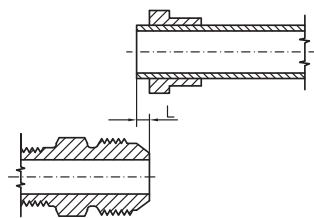

Diam. est. tubo		Lunghezza L mm.	Diam. est. tubo		Lunghezza L mm.
mm.	Pollici		mm.	Pollici	
6	1/4"	2	18		3
8	5/16"	2	20	3/4"	3
10	3/8"	2	25	1"	3
12	1/2"	2,5	30		4
14		2,5	32	1" 1/4	4
15		2,5	38	1" 1/2	4
16	5/8"	2,5			

En cas d'évasement du tube trop court, presque tout la surface de contact du raccord sera inutilisée. Il s'ensuit le risque que la surface du tube soit écrasée à cause de la surface de contact insuffisante. Dans ce cas, la sécurité maximum contre des fuites ou des ruptures de l'évasement n'est pas garantie.

En cas d'évasement du tube trop long, on aura des problèmes de filetage de l'écrou qui se bloquera en empêchant le montage correct du raccord. Pour garantir le fonctionnement optimum, l'évasement doit être perpendiculaire et concentrique au tube et à la fourreau. Des défauts relatifs à la perpendicularité et la concentricité peuvent être causés par une coupe erronée du tube ou par une formation irrégulière provoquée par un outil de coupe ou un évasement défectueux. Lorsque l'on doit couper le tube, il convient de prendre en considération une certaine valeur qui doit être ajoutée par la suite à la longueur de la ligne. Pour déterminer cette longueur, il est nécessaire d'ajouter à la longueur voulue du tube une longueur "L" qui représente la partie du cône du raccord qui entre dans la partie évasée du tube. En outre chaque évasement requiert une longueur de tube comprise entre 0,5 et 1 mm. selon l'épaisseur du tube lui-même. Consulter la table relative à la longueur "L".

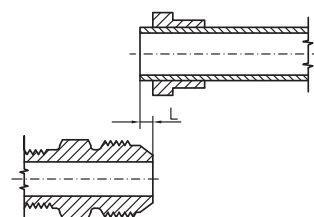

Diam. est. tube		Longueur L mm.	Diam. est. tube		Longueur L mm.
mm.	Pouces		mm.	Pollici	
6	1/4"	2	18		3
8	5/16"	2	20	3/4"	3
10	3/8"	2	25	1"	3
12	1/2"	2,5	30		4
14		2,5	32	1" 1/4	4
15		2,5	38	1" 1/2	4
16	5/8"	2,5			



If the pipe flaring is too short, nearly all the fitting's contact surface will go unutilised. There is therefore the risk that the pipe surface will be squashed owing to the inadequate contact surface. In such cases maximum safety against leaks or the flare breaking is not guaranteed. If the pipe flaring is too long, problems arise with the nut thread which will get jammed and thus prevent the fitting from being assembled properly. To function most efficiently, the flaring must be perpendicular and concentric with the pipe and bush. Imperfect perpendicularity and concentricity could be the result of the pipe being cut incorrectly or an irregular formation caused by a cutting tool or defective flaring. When the pipe needs to be cut, a certain length must be taken into account which must then be added to the length of the line. To establish how long this is, a length "L" representing the part of the fitting cone that enters the flared section of the pipe must be added to the required length of the pipe. Furthermore, each flaring requires a length of pipe between 0.5 and 1 mm; according to the width of the pipe itself. Check the table showing lengths of "L".

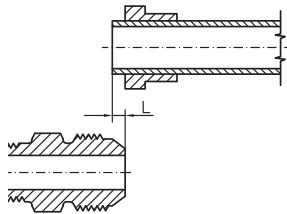

Outside pipe diam		Lenght L mm.	Outside pipe diam		Lenght L mm.
mm.	Inches		mm.	Inches	
6	1/4"	2	18		3
8	5/16"	2	20	3/4"	3
10	3/8"	2	25	1"	3
12	1/2"	2,5	30		4
14		2,5	32	1" 1/4	4
15		2,5	38	1" 1/2	4
16	5/8"	2,5			

Bei einer zu kurzen Bördelung des Rohres wird fast die gesamte Kontaktfläche der Verschraubung nicht belastet. Dadurch entsteht die Gefahr, daß die Rohroberfläche aufgrund der ungenügenden Kontaktfläche zerdrückt wird. In diesem Fall wird keine maximale Sicherheit gegen Leckagen oder Bruchstellen der Bördelung gewährleistet. Bei einer zu langen Bördelung des Rohres entstehen Probleme mit dem Überwurfmuttergewinde, welches blockiert und damit die korrekte Montage der Verschraubung verhindert. Zur Gewährleistung einer optimalen Funktionsweise muß die Bördelung lotrecht und konzentrisch zu Rohr und Stützhülse sein. Fehler der lotrechten Lage und der Konzentrität können durch falschen Schnitt des Rohres, Schneidfehler mit einem Schneidwerkzeug oder falscher Bördelung hervorgerufen werden. Wenn das Rohr geschnitten werden soll, ist ein bestimmter Wert zu beachten, der in der Folge zu der Länge der Linie addiert wird. Zur Bestimmung dieser Länge ist der gewünschten Rohrlänge eine Länge "L" hinzuzufügen, die den Teil des Konus der Verschraubung darstellt, der in das gebördelte Teil des Rohrs eingeführt wird. Jede Bördelung erfordert ausserdem eine Rohrlänge zwischen 0,5 und 1 mm, je nach Stärke des Rohres. Länge "L" siehe Tabelle.

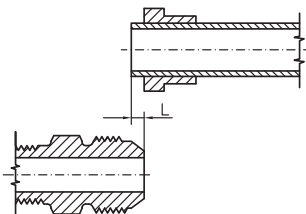

Aussendurchm. D Rohres		Lange L mm.	Aussendurchm. D Rohres		Lange L mm.
mm.	Zoll		mm.	Zoll	
6	1/4"	2	18		3
8	5/16"	2	20	3/4"	3
10	3/8"	2	25	1"	3
12	1/2"	2,5	30		4
14		2,5	32	1" 1/4	4
15		2,5	38	1" 1/2	4
16	5/8"	2,5			

Si el abocardado del tubo es muy corto, la práctica totalidad de la pared de contacto del racor no será utilizada, y la pared del tubo correrá el peligro de ser aplastada por insuficiencia de superficie de contacto. En estos casos no se ofrece la seguridad máxima contra fugas, roturas del abocardado o desencajes. Si el abocardado del tubo es muy largo, producirá una interferencia en los filetes de la tuerca, la cual quedará bloqueada, por lo que no podrá efectuarse el correcto montaje de racor. Para operar correctamente el abocardado debe ser perpendicular y concéntrico al tubo y a la férula. Los defectos de perpendicularidad y de concentricidad son imputables a un corte incorrecto del tubo o a una formación irregular realizada por un útil de cortar o abocardado defectuoso. A la hora de cortar el tubo, se ha de contar con unas cotas que deben añadirse a la longitud de la línea. Para determinar dicha longitud, hay que añadir a la longitud deseada del tubo la longitud "L" que representa la parte entrante de cono del racor en la parte abocardada del tubo. Además, cada abocardado absorbe una longitud de tubo entre 0,5 y 1 mm., según el espesor del tubo. Mirar tabla longitud "L".

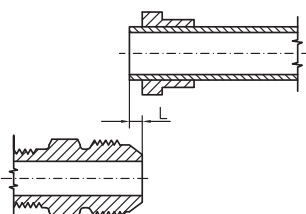

Ø ext. tubo		Longitud L mm.	Ø ext. tubo		Longitud L mm.
mm.	Pulgadas		mm.	Pulgadas	
6	1/4"	2	18		3
8	5/16"	2	20	3/4"	3
10	3/8"	2	25	1"	3
12	1/2"	2,5	30		4
14		2,5	32	1" 1/4	4
15		2,5	38	1" 1/2	4
16	5/8"	2,5			



VALORI DI PRESSIONE MASSIMA DI ESERCIZIO PER RACCORDI SAE JIC 514-37°
VALEURS MAXIMA DE PRESSION DE SERVICE POUR RACCORDS SAE JIC 514-37°
MAXIMUM RATED PRESSURE VALUES FOR SAE JIC 514-37° COUPLINGS
MAX. BETRIEBSDRUCKWERTE FÜR SAE ANSCHLUSSE JIC 514-37°
VALORES DE PRESION MAXIMA DE FUNCIONAMIENTO PARA RACORES SAE JIC 514-37°

La pressione NOMINALE PN corrisponde ad un fattore di sicurezza di: PN x 4 volte.
La pression NOMINALE PN correspond à un facteur de sécurité de: PN x 4 fois.
PN rated pressure corresponds to a safety factor of PN x 4 times.
Der Wenn Druck PN entspricht enthält einem Sicherheitsfaktor von PN x 4.
La presión NOMINAL PN corresponde a un factor de seguridad de PN x 4 veces.

Le pressioni indicate sono da intendersi le MASSIME DI ESERCIZIO compresi i valori di punta in condizioni di lavoro NORMALI e con temperature d'esercizio MASSIME AMMISSIBILI
-40°C + 120°C per l'acciaio (DIN 3859) -60°C + 20°C per l'acciaio INOX AISI 316L

Les pressions indiquées sans les spécifications des tableaux des raccords doivent être considérées comme pressions maximales d'utilisation y compris les valeurs de crête dans des conditions NORMALE et à des températures d'utilisation maximales admissibles TB (DIN 2401) de:
-40°C +120°C pour l'acier (DIN 3859) -60°C +20°C pour l'acier INOX AISI 316L

The pressure values indicated in the relative coupling tables are understood as the maximum operating pressure values inclusive of peak value during standard operating conditions, with maximum permissible TB (DIN 2401) operating temperatures of:
-40°C + 120°C for steel (DIN 3859) -60°C+ 20°C for AISI 316 L stainless steel

Die in den Tabellen für Anschlußstücke angegebenen Drücke entsprechen den maximalen Betriebsdruckwerten einschließlich der Spitzenwerte unter NORMALEN Betriebsbedingungen und bei den höchsten zulässigen Betriebstemperaturen TB (DIN 2401) von:
-40°C + 120°C für Stahl (DIN 3859) -60°C+ 20°C für rostfreien Stahl AISI 316L

Las presiones indicadas deben interpretarse como las máximas de funcionamiento, incluidos los valores punta en condiciones normales de trabajo y con las siguientes temperaturas de funcionamiento MAXIMAS ADMISIBLES.
-40°C + 120°C para el acero (DIN 3859) -60°C+20°C para el acero INOX AISI 316L

Per l'acciaio inox sono necessarie riduzioni di pressione in rapporto all'aumento della temperatura di esercizio.
A noter que pour l'acier INOX des réductions de pression par rapport à l'augmentation de la température d'utilisation sont nécessaires.
With stainless steel, pressure values must be reduced in accordance with increases in the operating temperature.
Für rostfreien Stahl sind Druckminderungen im Verhältnis zum Anstieg der Betriebstemperatur notwendig.
Para el acero inoxidable son necesarias reducciones de presión con respecto al aumento de la temperatura de funcionamiento
+ 50°C = -4%~ della pressione / de la pression / pressure / Druck / con respecto a la presión
+ 100°C = -10%~ della pressione / de la pression / pressure / Druck / con respecto a la presión
+ 200°C = -20%~ della pressione/de la pression/pressure/Druck/con respecto a la presión
+ 300°C = -30%~ della pressione / de la pression / pressure / Druck / con respecto a la presión
+ 400°C = -35%~ della pressione / de la pression / pressure / Druck / con respecto a la presión

Materiale e temperature di ESERCIZIO delle guarnizioni impiegate sui raccordi SAE JIC 514
NBR (Perbunam® - BAYER) = -35°C + 100°C per l'acciaio (DIN 3859)
FPM (Viton® - DU PONT) = -25°C + 200°C per acciaio INOX AISI 316L

Matériau et températures d'utilisation des joints pour les raccords SAE JIC 514
NBR (Perbunam® - BAYER) = -35°C + 100°C pour l'acier (DIN 3859)
FPM (Viton® - DU PONT) = -25°C + 200°C pour l'acier INOX AISI 316L

Materials and operating temperatures for SAE JIC 514 coupling seals
NBR (Perbunam®) - BAYER) = -35°C + 100°C for steel (DIN 3859)
FPM (Viton® - DU PONT) = -25°C + 200°C for AISI 316L stainless steel

Material und Betriebstemperatur der an Anschlußstücken SAE JIC 514 verwendeten Dichtungen
NBR (Perbunam® - BAYER) = -35°C + 100°C für Stahl (DIN 3859)
FPM (Viton® - DU PONT) = -25°C+ 200°C für rostfreien Stahl AISI 316L

Material y temperaturas de funcionamiento de las juntas empleadas en los racores SAE JIC 514
NBR (Perbunam® - BAYER) = -35°C + 100°C para el acero (DIN 3859)
FPM (Viton® - DU PONT) = -25°C+ 200°C para el acero INOX AISI 316L

TENUTA ERMETICA DELLE FILETTATURE CONICHE

Le filettature coniche non sono a tenuta ermetica. Per ottenere una tenuta ermetica, a prove di perdite, sono necessari elementi di tenuta supplementari. Validi sono i nastri di tenuta PTFE (esempio TEFLON).

ETANCHEITE FILETAGES CONIQUES

Les filetages coniques ne sont étanchés. Pour obtenir une étanchéité à l'épreuve de toute perte, des éléments d'étanchéité supplémentaires sont nécessaires. A ce propos, les ruban d'étanchéité PTFE sont très efficaces (es. TEFLON).

HERMETIC SEALS FOR TAPER THREADS

Taper threads are not hermetically sealed. To obtain a watertight hermetic seal additional sealing elements are required such as PTFE sealing tape (eg. TEFLON).

HERMETISCHE ABDICHTUNG BEI KEGLIGEN GEWINDEN

Die kegligen Gewinde schließen nicht hermetisch dicht. Um eine leckagesichere hermetische Abdichtung zu erzielen, müssen zusätzliche Dichtungselemente eingefügt werden. Gut sind PTFE-Dichtungsbänder (z.B. TEFLON).

SELLADO HERMÉTICO DE LAS RUSCAS CÓNICAS

Las ruscas cónicas no son de sellado hermético. Para obtener un sellado hermético a prueba de pérdidas, se necesitan elementos complementarios, tales como las civatas de sellado PTFE (por ejemplo, TEFLON).



TIPI DI FILETTATURE IMPIEGATE SU RACCORDI SAE J 514
AN SAE J 514 ANSCHLUBSTÜCKEN VERWENDETE GEWINDETYPEN
TYPES OF THREAD FOR SAE J 514 COUPLINGS
TYPES DE FILETAGE UTILISÉS POUR LES RACCORDS SAE J 514
TIPOS DE ROSCAS EMPLEADOS EN LOS RACORES SAE J 514

- FILETTATURA BSPP (GAS CILINDRICA) UNI ISO 228 - GEWINDE BSPP (ZYLINDER-GASGEWINDE) UNI ISO 228 - BSPP THREAD (GAS-TYPE CYLINDRICAL) UNI ISO 228 - FILETAGE BSPP (GAZ CYLINDRIQUE) UNI ISO 228 - ROSCADO BSPP (GAS CILINDRICO) UNI ISO 228

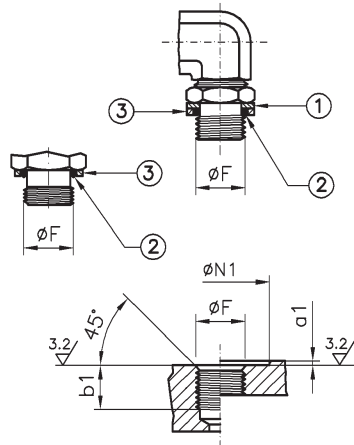

Ø F BSPP	max. a1	min. b1	min. Ø N1	O-Ring Jointe torique Junta tórica (Shore A ca. 90)	Coppia di serraggio Anzugsmoment Torque wrench Couple serrage Pares de apriete MT (Nm) ± 10%
1/8" - 28	1,0	8	16,5	7,97 x 1,88	20
1/4" - 19	1,5	11	21,5	10,77 x 2,62	45
3/8" - 19	1,5	11	25,5	13,94 x 2,62	70
1/2" - 14	1,5	14	30,0	17,86 x 2,62	110
3/4" - 14	1,5	16	36,5	23,47 x 2,62	190
1" - 11	2,0	19	46,0	29,74 x 3,53	310
1" 1/4 - 11	2,0	21	57,0	37,69 x 3,53	450
1" 1/2 - 11	2,0	21	63,5	44,04 x 3,53	540

- ① - Rondella fissa antiestruzione / Feste Druckscheibe / Fixed anti-extrusion ring / Rondelle fixe anti-extrusion / Arandela fija a prueba de extrusión
- ② - O-Ring / Jointe torique / Junta tórica
- ③ - Rondella mobile tenuta O-Ring / Bewegliche Unterlegscheibe f. O-Ring / Mobile O-Ring seal ring / Rondelle mobile d étanchéité (O-Ring) / Arandela móvil de retencion junta tórica

- FILETTATURA UNF (ANSI/ASME B.1.1.1989) - GEWINDE UNF (ANSI/ASME B.1.1.1989) - UNF THREAD (ANSI/ASME B.1.1.1989) - FILETAGE UNF (ANSI/ASME B.1.1.1989) - ROSCADO UNF (ANSI/ASME B.1.1.1989)

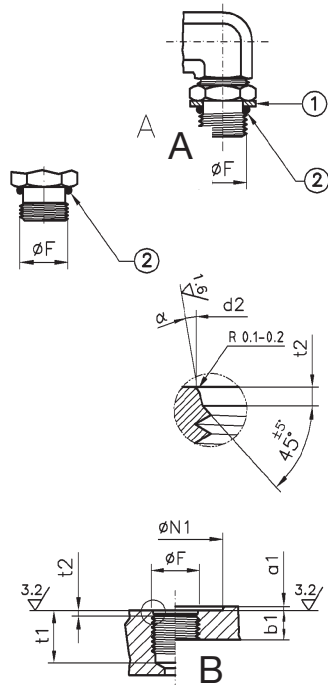

Ø F UNF	max. a1	min. b1	+0,1 d2	min. Ø N1	min. t1	+0,3 t2	±1° α	O-Ring Jointe torique Junta tórica (Shore A ca. 90)	Coppia di serraggio Anzugsmoment Torque wrench Couple serrage Pares de apriete MT (Nm) ± 10%
7/16-20	1,0	12	12,4	21	14	2,4	12°	8,92 x 1,83	20
1/2 - 20	1,0	12	14,0	23	14	2,4	12°	10,52 x 1,83	35
9/16-18	1,0	13	15,6	26	16	2,5	12°	11,89 x 1,98	45
3/4-16	1,5	15	20,6	32	18	2,6	15°	16,36 x 2,21	70
7/8-14	1,5	17	23,9	35	20	2,6	15°	19,18 x 2,46	100
1"1/16-12	1,5	20	29,2	42	24	3,3	15°	23,47 x 2,95	170
1"5/16-12	2,0	20	35,5	50	24	3,3	15°	29,74 x 2,95	310
1"5/8 - 12	2,5	20	43,5	60	24	3,4	15°	37,47 x 3,00	330
1"7/8-12	2,5	20	49,8	65	24	3,4	15°	43,69 x 3,00	420

- ① - Rondella fissa antiestruzione / Feste Druckscheibe / Fixed anti-extrusion ring / Rondelle fixe anti-extrusion / Arandela fija a prueba de extrusión
- ② - O-Ring / Jointe torique / Junta tórica
- A** Perno filettato UNF-2A con guarnizione O-Ring (SAE J 514)
Einschraubzafen UNF-2A mit O-Ring Dichtung (SAE J 514)
Male stud UNF-2A for O-Ring sealing (SAE J 514)
Filetage UNF-2A avec étanchéité par jointe torique (SAE J 514)
Perno roscado UNF-2A con junta tórica (SAE J 514)
- B** Foro filettato UNF-2B per guarnizione O-Ring (SAE J 514)
Einschraubloch UNF-2B für O-Ring Dichtung (SAE J 514)
Port UNF-2B for O-Ring sealing (SAE J 514)
Taraudage UNF-2B pour étanchéité par jointe torique (SAE J 514)
Orificio roscado UNF 2B para junta tórica (SAE J 514)



- FILETTATURA METRICA CILINDRICA (ISO 6149) - METRISCHES ZYLINDERGEWINDE (ISO 6149) - METRIC CYLINDRICAL THREAD (ISO 6149) - FILETAGE METRIQUE CYLINDRIQUE (ISO 6149) - ROSCADO METRICO CILINDRICO (ISO 6149)

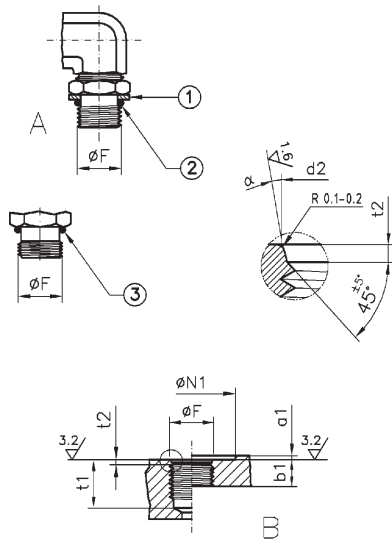

Ø F	max. a1	min. b1	+0.1 d2	min. Ø N1	min. t1	+0.4 t2	±1° α	O-Ring Jointe torique Junta tórica (Shore A ca. 90)	Coppia di serraggio Anzugsmoment Torque wrench Couple serrage Pares de apriete MT (Nm) ± 10%
10 x 1	1,0	10,0	11,1	20	11,5	1,6	12°	8,1 x 1,6	20
12 x 1,5	1,5	11,5	13,8	23	14,0	2,4	15°	9,3 x 2,2	35
14 x 1,5	1,5	11,5	15,8	25	14,0	2,4	15°	11,3 x 2,2	45
16 x 1,5	1,5	13,0	17,8	28	15,5	2,4	15°	13,3 x 2,2	55
18 x 1,5	2,0	14,5	19,8	30	17,0	2,4	15°	15,3 x 2,2	70
22 x 1,5	2,0	15,5	23,8	34	18,0	2,4	15°	19,3 x 2,2	100
27 x 2	2,0	19,0	29,4	40	22,0	3,1	15°	23,6 x 2,9	170
33 x 2	2,5	19,0	35,4	49	22,0	3,1	15°	29,6 x 2,9	310
42 x 2	2,5	19,5	44,4	60	22,5	3,1	15°	38,6 x 2,9	330
48 x 2	2,5	22,0	50,4	66	25,0	3,1	15°	44,6 x 2,9	420

- ① - Rondella fissa antiestrusione / Feste Druckscheibe / Fixed anti-extrusion ring / Rondelle fixe anti-extrusion / Arandela fija a prueba de extrusión
② - O-Ring / Jointe torique / Junta tórica

- FILETTATURA METRICA CILINDRICA - METRISCHES ZYLINDERGEWINDE - METRIC CYLINDRICAL THREAD
- FILETAGE METRIQUE CYLINDRIQUE - ROSCADO METRICO CILINDRICO.

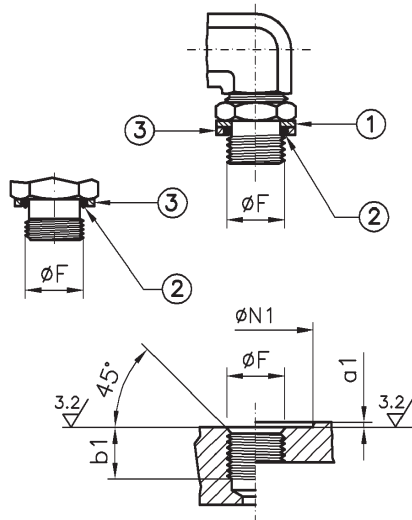

Ø F	max. a1	min. b1	min. Ø N1	O-Ring Jointe torique Junta tórica (Shore A ca. 90)	Coppia di serraggio Anzugsmoment Torque wrench Couple serrage Pares de apriete MT (Nm) ± 10%
10 x 1	1,0	8	15	8,1 x 1,6	20
12 x 1,5	1,5	12	18	9,3 x 2,2	35
14 x 1,5	1,5	12	20	11,3 x 2,2	45
16 x 1,5	1,5	12	23	13,3 x 2,2	55
18 x 1,5	2,0	12	25	15,3 x 2,2	70
22 x 1,5	2,0	14	28	19,3 x 2,2	130
27 x 2	2,5	16	33	23,6 x 2,9	190
33 x 2	2,5	18	41	29,6 x 2,9	310
42 x 2	2,5	20	51	38,6 x 2,9	450
48 x 2	2,5	22	56	44,6 x 2,9	540

- ① - Rondella fissa antiestrusione / Feste Druckscheibe / Fixed anti-extrusion ring / Rondelle fixe anti-extrusion / Arandela fija a prueba de extrusión
② - O-Ring / Jointe torique / Junta tórica
③ - Rondella mobile tenuta O-Ring / Bewegliche Unterlegscheibe f. O-Ring / Mobile O-Ring. seal ring / Rondelle mobile d'étanchéité (O-Ring) / Arandela móvil de retencion junta tórica

FILETTATURA BSPT (GAS CONICA) UNI ISO 7/1
FILETAGE BSPT (GAZ CONIQUE) UNI ISO 7/1
BSPT THREAD (TAPERED GAS-TYPE) UNI ISO 7/1
GEWINDE BSPT (KEGELFÖRMIGES GASGEWINDE) UNI ISO 7/1
ROSCADO BSPT (GAS CONICO) UNI ISO 7/1

Ø F BSPT	b
1/8" -28	4,0
1/4" -19	6,0
3/8" -19	6,4
1/2" 14	8,2
3/4" 14	9,5
1" - 11	10,4
1" 1/4-11	12,7
1" 1/2-11	12,7

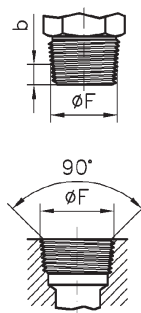

FILETTATURA NPT (ANSI/ASME B.1.20.1.1983)
FILETAGE NPT (ANSI/ASME B.1.20.1.1983)
NPT THREAD (ANSI/ASME B.1.20.1.1983)
GEWINDE NPT (ANSI/ASME B.1.20.1.1983)
ROSCADO NPT (ANSI/ASME B.1.20.1.1983)

Ø F NPT	b
1/8" -27	4,1
1/4" -18	5,8
3/8" -18	6,1
1/2" -14	8,1
3/4" -14	8,6
1" -11 1/2	10,2
1" 1/4-11 1/2	10,7
1" 1/2-11 1/2	10,7



- ESTREMITA' FILETTATE - EINSCHRHAUBGEWINDFE FEINGEWINDE - THREAD COUPLING - UNIONS FILETEES - UNIONES ROSCADAS

Perno filettato forma E
DIN 3852 Foglio 11
Tenuta mediante guarnizione

Einschraubzapfen Form E
DIN 3852 Teil 11
Dichtheit durch Dichtung.

Eje roscado forma X
segùn DIN 3852 Hoja 1-2
(para roscado cilindrico)

Foro filettato forma X
secondo DIN 3852 Foglio 1-2
(per filetti d'avvitamento cilindrico)

Einschraubloch Form X
DIN 3852 Teil 1-2
(für zylindrische Einschraubzapfen)

Agujero roscado forma X
segùn DIN 3852 Hoja 1-2
(para roscado cilindrico)

Male stud, form E
DIN 3852, Part 11
Packing-ensured tightness.

Implantation, forme E
DIN 3852, Partie 11
Etanchéité par garniture.

Port form X
to DIN 3852, Part 1-2
(for parallel stud thread)

Trou taraudé forme X
selon DIN 3852, Partie 1-2
(pour filetage mâle cylindrique)

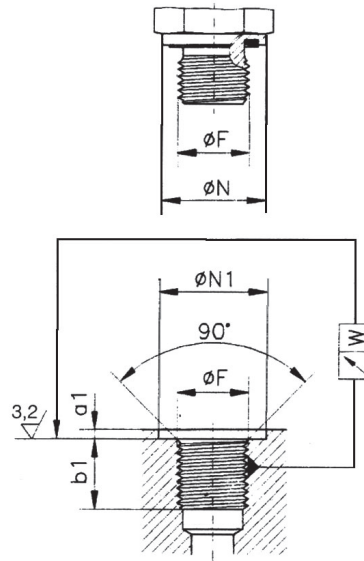

Filettatura gas cilindrica - Whitworth - Rohrgewinde zylindrisch
Thread B.S.P. parallel - Filetage gaz cylindrique - Rosca gas cilindrica

Filettatura metrica cilindrica - Metrisches Feingewinde zylindrisch
Thread metric parallel - Filetage métrique cylindrique - Rosca métrica cilindrica

Ø F	+0,4 Ø N1	Ø N	a1 MAX	b1 MIN	W	Coppia di serraggio Anzugsmoment Torque wrench Couple serrage Pares de apriete MT (Nm) ± 10%
G 1/8"-28	15	13,9	1	8	0,1	20
G 1/4"-19	20	18,9	1,5	12	0,1	50
G 3/8"-1	23	21,9	2	12	0,1	85
G 1/2"-14	28	26,9	2,5	14	0,1	115
G 3/4"-14	33	31,9	2,5	16	0,2	200
G 1" -11	41	39,9	2,5	18	0,2	380
G 1" 1/4-11	51	49,9	2,5	20	0,2	500
G 1" 1/2-11	56	54,9	2,5	22	0,2	600

Ø F	+0,4 Ø N1	Ø N	a1 MAX	b1 MIN	W	Coppia di serraggio Anzugsmoment Torque wrench Couple serrage Pares de apriete MT (Nm) ± 10%
M 10 x 1	15	13,9	1	8	0,1	20
M 12 x 1,5	18	16,9	1,5	12	0,1	40
M 14 x 1,5	20	18,9	1,5	12	0,1	55
M 16 x 1,5	23	21,9	1,5	12	0,1	70
M 18 x 1,5	25	23,9	2	12	0,1	90
M 22 x 1,5	28	26,9	2,5	14	0,1	145
M 27 x 2	33	32	2,5	16	0,2	200
M 33 x 2	41	39,9	2,5	18	0,2	380
M 42 x 2	51	49,9	2,5	20	0,2	500
M 48 x 2	56	54,9	2,5	22	0,2	600

* Classe di tolleranza (A) valida per filettature maschio

* Toleranzklasse (A) gültig nur für Gewindezapfen

* Tolerance class (A) is only valid for male threads

* Classe de tolérance (A) valable seulement pour filetages mâle

* Classe de tolerancia (A) válida para roscas macho



ISTRUZIONI DI MONTAGGIO - MONTAGEANLEITUNG - ASSEMBLY INSTRUCTIONS - INSTRUCTIONS DE MONTAGE - INSTRUCCIONES DE MONTAJE

A

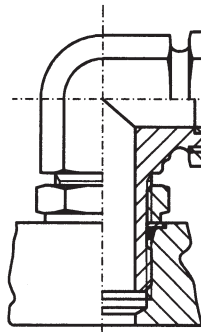

- Versione con filetto UNF/UN e Metrico cilindrico ISO 6149
- Ausführungen UNF/UN-Gewinde Metrisches Zylindrisch ISO 6149
- Version with UNF/UN-thread Metric parallel-thread ISO 6149
- Version avec filetage UNF/UN et Métrique cylindrique ISO 6149
- Versiones con rosca UNF/UN y Metrica cilíndrica ISO 6149

B

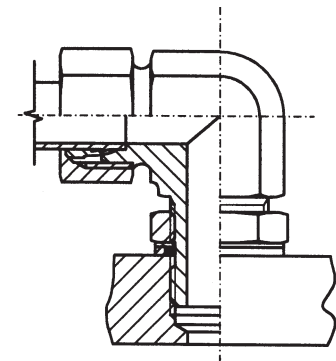

- Versione con filetto Gas cilindrico (BSPP) Metrico cilindrico
- Ausführungen Gewinde BSPP Metrisches Zylindrisch
- Version with BSP parallel Metric cylindrical thread
- Version avec Filetage Gaz cylindrique (BSPP) Métrique cylindrique
- Versiones con rosca Gas cilindrico (BSPP) Metrico cilindrico

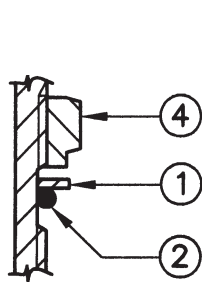

- Svitare il più possibile il controdado. ④
- La guarnizione O-Ring ② e la rondella fissa antiestrusione ① devono trovarsi alla estremità superiore della gola di scarico filetto.
- Oleare la guarnizione O-Ring.
- Nella versione con filetto gas e filetto metrico cilindrico (W) infilare la rondella mobile ③ sulla guarnizione O-Ring.
- Screw back bulkhead nut ④ as far as it goes.
- O-Ring ② and fixed anti-extrusion ring ① should be at the upper end of the notch.
- Oil the O-Ring.
- In the versions with BSPP, Metric cylindrical (W) thread slip mobile ring ③ over O-Ring.

- Kontermutter ④ so weit wie möglich zurückschrauben.
- O-Ring ② und Feste Druckscheibe ① müssen sich am oberen Ende des Freistichs befinden.
- O-Ring ölen.
- Bei den Ausführungen mit withworth-Rohrgewinde, Metrisches Zylindrischgewinde (W) den Bewegliche Unterlegscheibe über ③ O-Ring schieben.

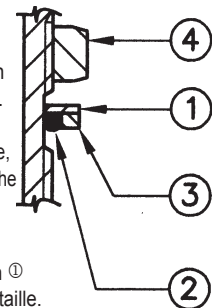

- Dévisser le contre-écrou ④ le plus possible.
- Jointe torique ② et rondelle fixe anti-extrusion ① doivent se trouver tout au bout haut de l'entaille.
- Huiler la Jointe torique.
- Dans le version avec filet GAZ, Métrique cylindrique (W) mettre la rondelle mobile d'étanchéité ③ sur la Jointe torique.

- Desenroscar la contratuercia ④ lo más posible.
- Junta tórica ② y arandela fija a prueba de extrusión ① debe encontrarse en la extremidad superior de la muesca.
- Lubrificar la junta tórica.
- En las versiones con rosca GAS Metrico cilindrico (W) poner la arandela móvil ③ sobre la junta tórica.

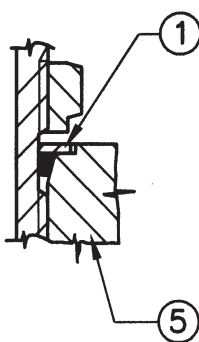

- Avvitare manualmente il raccordo nella sede filettata ⑤ fino a quando la rondella mobile ③ o la rondella fissa antiestrusione ① non appoggia sulla superficie lavorata. ⑤
- Per regolare il raccordo nella posizione desiderata farlo girare in senso antiorario di un giro al massimo
- Manually screw the fitting into the screwing, hole ⑤ till mobile ring ③ or fixed anti-extrusion ring ① comes to rest.
- To adjust in the wanted position turnback by maximum one turn.

- Verschraubung in das Einschraubloch ⑤ von Hand, endrehen, bis Feste Druckscheibe ① oder Bewegliche Unterlegscheibe ③ aufliegt.
- Einteilung in die gewünschte Richtung durch Zurückdrehen um höchstens eine Umdrehung.

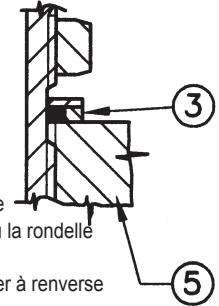

- Visser manuellement le raccord dans le trou de vissage jusqu'à ce que la rondelle mobile ③ ou la rondelle fixe anti-extrusion ① appuie.
- Pour le régler dans la position voulue, le tourner à renverse d'un tour au maximum.

- Atornillar manualmente el racor en el agujero de atornillamiento ⑤ hasta que la arandela móvil ③ o la arandela fija a prueba de extrusión, apoye.
- Para ajustarlo en la posición deseada, hacer girar hacia atrás una vuelta al máximo.

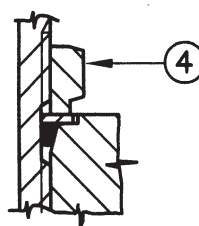

- Serrare completamente il controdado ④ tenendo il corpo del raccordo, con una chiave fissa, nella posizione desiderata.
- Tighten bulkhead nut ④ completely while keeping the fitting body in the wanted position.

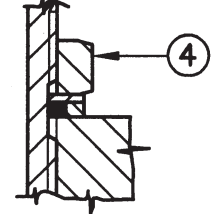

- Kontermutter ④ festziehen und dabei den Verschraubungskörper in der gewünschten Richtung halten.
- Serrer complètement le contre-écrou tout en tenant le corps du raccord dans la position voulue.



- Apretar completamente la contratuercia ④ teniendo el cuerpo del racor en la posición deseada.





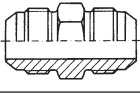
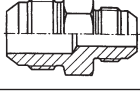
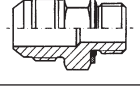
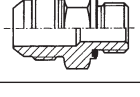
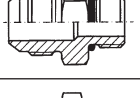
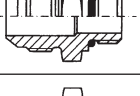
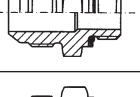
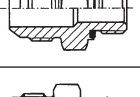
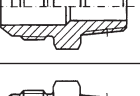
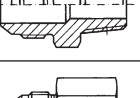
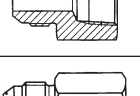
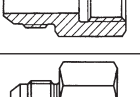
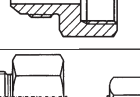
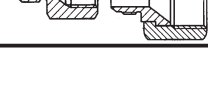





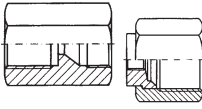

INDICE - INDEX

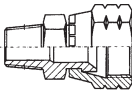
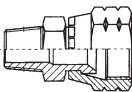
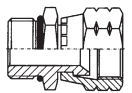
DESCRIZIONE - DESCRIPTION - BESCHREIBUNG - DESCRIPTION	CODICE - REFERENCE - CODE - BEST NR. - REFERENCIA		PAG.
DADO ECROU NÜT UBERWURFMUTTER TUERCA		BA.13	23
BUSSOLA: TUBO POLLICI/TUBO METRICO FOURREAU: TUBE POUÇES/METRIQUE BUSH: INCHES TUBE/METRIC TUBE STÜTZHÜLSE: METRISCHES ROHR/ZÖLLIGES ROHR FERULA: TUBO EN PULGADAS/TUBO METRICO		BA.15 BA.83	
CORPO: UNIONE DIRITTA CORPS: UNION DROIT BODY: STRAIGHT COUPLING KÖRPER: GERADE VERSCHRAUBUNG CUERPO: ADAPTADOR RECTO		BA.17	24
CORPO: UNIONE DIRITTA RIDOTTA CORPS: UNION DROIT DE REDUCTION BODY: REDUCED STRAIGHT COUPLING KÖRPER: GERADE VERSCHRAUBUNG - REDUZIERUNG CUERPO: ADAPTADOR REDUCIDO RECTO		BA.18	
CORPO: TERMINALE DIRITTO MASCHIO BSPP CORPS: TERMINAL DROIT MALE BSPP BODY: MALE STUD BSPP KÖRPER: GERADE EINSCHRAUB BSPP CUERPO: ADAPTADOR RECTO MACHO BSPP		BA.19	25
CORPO: TERMINALE DIRITTO MASCHIO BSPP (FORMA E DIN 3852) CORPS: TERMINAL DROIT MALE BSPP (FORME E DIN 3852) BODY: MALE STUD BSPP (TYPE E DIN 3852) KÖRPER: GERADE EINSCHRAUB BSPP (FORM E DIN 3852) CUERPO: ADAPTADOR RECTO MACHO BSPP (FORMA E DIN 3852)		BA.20	26
CORPO: TERMINALE DIRITTO MASCHIO UNF 2A CORPS: TERMINAL DROIT MALE UNF 2A BODY: MALE STUD UNF 2A KÖRPER: GERADE EINSCHRAUB UNF 2A CUERPO: ADAPTADOR RECTO MACHO UNF 2A		BA.21	27
CORPO: TERMINALE DIRITTO MASCHIO METRICO CILINDRICO - ISO 6149.3 CORPS: TERMINAL DROIT MALE CYLINDRIQUE METRIQUE - ISO 6149.3 BODY: MALE STUD METRIC PARALLEL - ISO 6149.3 KÖRPER: GERADE EINSCHRAUB METRISCH ZYLINDRISCH - ISO 6149.3 CUERPO: ADAPTADOR RECTO MACHO METRICO-CILINDRICO - ISO 6149.3		BA.23	28
CORPO: TERMINALE DIRITTO MASCHIO METRICO CILINDRICO - RONDELLA TENUTA O-RING CORPS: TERMINAL DROIT MALE CYLINDRIQUE METRIQUE - RONDELLE D'ETANCHEITE O-RING BODY: MALE STUD METRIC PARALLEL - O-RING SEAL RING KÖRPER: GERADE EINSCHRAUB METRISCH ZYUNDRISCH - BEWEGLICHE UNTERLEGSCHIBE F.O-RING CUERPO: ADAPTADOR RECTO MACHO METRICO CILINDRICO - ARANDELA DE RETENCION JUNTA TORICA		BA.23W	29
CORPO: TERMINALE DIRITTO MASCHIO METRICO CILINDRICO (FORMA E DIN 3852) CORPS: TERMINAL DROIT MALE CYLINDRIQUE METRIQUE (FORME E DIN 3852) BODY: MALE STUD METRIC PARALLEL (TYPE E DIN 3852) KÖRPER: GERADE EINSCHRAUB METRISCH ZYLINDRISCH (FORMA E DIN 3852) CUERPO: ADAPTADOR RECTO MACHO METRICO CILINDRICO (FORMA E DIN 3852)		BA.24	30
CORPO: TERMINALE DIRITTO MASCHIO NPT CORPS: TERMINAL DROIT MALE NPT BODY: MALE STUD NPT KÖRPER: GERADE EINSCHRAUB NPT CUERPO: ADAPTADOR RECTO MACHO NPT		BA.25	31
CORPO: TERMINALE DIRITTO MASCHIO BSPT CORPS: TERMINAL DROIT MALE BSPT BODY: MALE STUD BSPT KÖRPER: GERADE EINSCHRAUBVERSCHRAUBUNG BSPT CUERPO: ADAPTADOR RECTO MACHO BSPT		BA.26	32
CORPO: TERMINALE DIRITTO FEMMINA NPT CORPS: TERMINAL DROIT FEMELLE NPT BODY: FEMALE STUD NPT KÖRPER: GERADE AUFSCHRAUB NPT CUERPO: ADAPTADOR RECTO HEMBRA NPT		BA.28	33
CORPO: TERMINALE DIRITTO FEMMINA BSPP CORPS: TERMINAL DROIT FEMELLE BSPP BODY: FEMALE STUD BSPP KÖRPER: GERADE AUFSCHRAUB BSPP CUERPO: ADAPTADOR RECTO HEMBRA BSPP		BA.29	34
CORPO: TERMINALE DIRITTO FEMMINA BSPP (RACCORDO PER MANOMETRO) CORPS: TERMINAL DROIT MALE FEMELLE BSPP (UNION POUR MANOMETRE) BODY: FEMALE STUD BSPP (GAUGE COUPLING) KÖRPER: GERADE AUFSCHRAUB BSPP (MANOMETER-VERSCHRAUBUNGEN) CUERPO: ADAPTADOR RECTO HEMBRA BSPP (GAS CILINDRICO)		BA.30	
CORPO: RIDUZIONE CORPS: REDUCTION BODY: STUD ADAPTOR KÖRPER: REDUZIERVERSCHRAUBUNG CUERPO: REDUCCION		BA.31	35



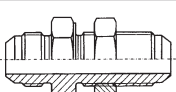
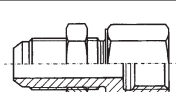
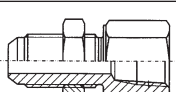
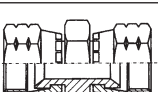







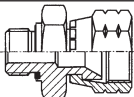
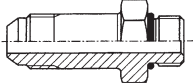



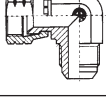

INDICE - INDEX

DESCRIZIONE - DESCRIPTION - BESCHREIBUNG - DESCRIPTION	CODICE - REFERENCE - CODE - BEST NR. - REFERENCIA	PAG.
CORPO: RACCORDO PER PRESA PRESSIONE CORPS: UNION PRISE DE PRESSION BODY: PRESSURE GAUGE CONNECTOR KÖRPER: ADAPTER FÜR PRÜ FANSCHLUß CUERPO: TOMA DE PRESIÓN		BA.33
CORPO: SALDABILE CORPS: A SAUDER BODY: WELDING KÖRPER: ANSCHWEISSBAR CUERPO: SOLDABLE		BA.39
TAPPO PER RACCORDO OBTURATEUR POUR RACCORD PLUG FOR FITTING VERSCHLUSSBOLZEN TAPON PARA RACOR		BA.43
TAPPO PER TUBO OBTURATEUR POUR TUBE PLUG FOR TUBE ROHRVERSCHLUSS TAPON PARA TUBO		BA.45
CORPO: ADATTATORE MASCHIO NPT CON DADO GIREVOLE JIG CORPS: ADAPTATEUR MALE NPT ECROU PIVOTANT JIC BODY: MALE STUD ADAPTOR NPT WITH ROTARY NUT JIC KÖRPER: EINSCHRAUBADAPTER NPT MIT DREHMUTTER JIC CUERPO: ADAPTADOR MACHO NPT CON TUERCA LOCA		BA.46
CORPO: ADATTATORE MASCHIO BSPT (CON DADO GIREVOLE JIC) CORPS: ADAPTATEUR MALE BSPT (ECROU PIVOTANT JIC) BODY: MALE STUD ADAPTOR BSPT (WITH ROTARY NUT JIC) KÖRPER: EINSCHRAUBADAPTER BSPT MIT GREHMUTTER JIC CUERPO: ADAPTADOR MACHO BSPT (CON TUERCA LOCA)		BA.47
CORPO: ADATTATORE MASCHIO UNF-2A CON DADO GIREVOLE JIC CORPS: ADAPTATEUR MALE UNF-2A ECROU PIVOTANT JIC BODY: MALE STUD ADAPTOR UNF-2A WITH ROTARY NUT JIC KÖRPER: EINSCHRAUBADAPTER UNF-2A MIT DREHMUTTER JIC CUERPO: ADAPTADOR MACHO UNF-2A CON TUERCA LOCA		BA.48
CORPO: ADATTATORE MASCHIO BSPP CON DADO GIREVOLE JIC CORPS: ADAPTATEUR MALE BSPP-ECROU PIVOTANT JIC BODY: MALE STUD ADAPTOR BSPP WITH ROTARY NUT JIC KÖRPER: EINSCHRAUBADAPTER BSPP MIT DREHMUTTER JIC CUERPO: ADAPTADOR MACHO BSPP CON TUERCA LOCA		BA.49
CORPO: ADATTATORE MASCHIO (METRICO CILINDRICO) - ISO 6149-3 CORPS: ADAPTATEUR MALE (CYLINDRIQUE METRIQUE) - ISO 6149-3 BODY: MALE STUD ADAPTOR (METRIC PARALLEL) - ISO 6149-3 KÖRPER: EINSCHRAUBADAPTER (METRISCH ZYLINDRISCH) - ISO 6149-3 CUERPO: ADAPTADOR MACHO (METRICO CILINDRICO) - ISO 6149-3		BA.50
CORPO: ADATTATORE MASCHIO (METRICO CILINDRICO) RONDELLA TENUTA O-RING CORPS: ADAPTATEUR MALE (CYLINDRIQUE METRIQUE) RONDELLE D'ETANCHEITÉ O-RING BODY: MALE STUD ADAPTOR (METRIC PARALLEL) O-RING SEAL RING KÖRPER: EINSCHRAUBADAPTER (METRISCH ZYLINDRISCH) BEWEGLICHE UNTERLEGSCHIBE F.O-RING CUERPO: ADAPTADOR MACHO (METRICO CILINDRICO) ARANDELA DE RETENCION JUNTA TORICA		BA.50W
ADATTATORE FLANGIA ADAPTATEUR BRIDE FLANGE ADAPTOR FLANSCHADAPTER ADAPTADOR BRIDA		BA.51
CORPO: UNIONE PASSAPARATIA DIRITTA CORPS: UNION TRAVERSEE DROITE BODY: BULKHEAD CONNECTION KÖRPER: GERADE SCHOTTVERSCHRAUBUNG CUERPO: UNION PASATABIQUE RECTO		BA.53
CORPO: UNIONE PASSAPARATIA MASCHIO-FEMMINA BSPP CORPS: UNION TRAVERSEE MALE-FEMELLE BSPP BODY: BULKHEAD CONNECTION MALE-FEMALE BSPP KÖRPER: EIN-AUFSCHRAUB GERADE SCHOTTVERSCHRAUBUNG BSPP CUERPO: UNION PASATABIQUE MACHO-HEMBRA BSPP		BA.55
CORPO: UNIONE PASSAPARATIA MASCHIO-FEMMINA NPT CORPS: UNION TRAVERSEE MALE-FEMELLE NPT BODY: BULKHEAD CONNECTION MALE-FEMALE NPT KÖRPER: EIN-AUFSCHRAUB GERADE SCHOTTVERSCHRAUBUNG NPT CUERPO: UNION PASATABIQUE MACHO-HEMBRA NPT		BA.56
CORPO: ADATTATORE FEMMINA CORPS: ADAPTATEUR FEMELLE BODY: FEMALE ADAPTOR KÖRPER: AUFSCHRAUBADAPTER CUERPO: ADAPTADOR HEMBRA		BA.57
CORPO: ADATTATORE MASCHIO BSPP (FORMA E DIN 3852) CORPS: ADAPTATEUR MALE BSPP (FORME E DIN 3852) BODY: MALE STUD ADAPTOR BSPP (TYPE E DIN 3852) KÖRPER: EINSCHRAUBADAPTER BSPP (FORM E DIN 3852) CUERPO: ADAPTADOR MACHO BSPP (FORMA E DIN 3852)		BA.58



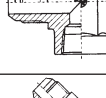

INDICE – INDEX

DESCRIZIONE - DESCRIPTION - BESCHREIBUNG - DESCRIPTION	CODICE - REFERENCE - CODE - BEST NR. - REFERENCIA	PAG.
CORPO: ADATTATORE MASCHIO METRICO CILINDRICO (FORMA E DIN 3852) CORPS: ADAPTATEUR MALE METRIQUE CYLINDRIQUE (FORME E DIN 3852) BODY: MALE STUD ADAPTOR METRIC PARALLEL (TYPE E DIN 3852) KÖRPER: EINSCHRAUBADAPTER METRISCH ZYLINDRISCH (FORM E DIN 3852) CUERPO: ADAPTADOR MACHO METRICO CILINDRICO (FORMA E DIN 3852)		BA.61
CORPO: TERMINALE DIRITTO MASCHIO UNF - LUNGO CORPS: TERMINAL DROIT MALE UNF - LONG BODY: STRAIGHT THREAD CONNECTOR LONG - UNF KÖRPER: EINSCHRAUBVERSCHRAUBUNG UNF MIT LANGEM SCHAFT CUERPO: ADAPTADOR RECTO MACHO UNF - PROLONGACIÓN		BA.62
CONTRODADO CONTRE-ECROU BULKHEAD NUT GEGENMUTTERN CONTRATUERCA		BA.99
CORPO: UNIONE GOMITO 90° CORPS: UNION COUDE 90° BODY: ELBOW COUPLING 90° KÖRPER: WINKELVERSCHRAUBUNG 90° CUERPO: UNION CODO 90°		ST.01
CORPO: GOMITO MASCHIO 90° BSPP CORPS: COUDE MALE 90° BSPP BODY: ELBOW MALE COUPLING 90° BSPP KÖRPER: WINKLEINSCHRAUBVERSCHRAUBUNG 90° BSPP CUERPO: CODO MACHO 90° BSPP		ST.05
CORPO: GOMITO MASCHIO 90° UNF 2A CORPS: COUDE MALE 90° UNF 2A BODY: ELBOW MALE COUPLING 90° UNF 2A KÖRPER: WINKLEINSCHRAUBVERSCHRAUBUNG 90° UNF 2A CUERPO: CODO MACHO 90° UNF 2A		ST.06
CORPO: GOMITO MASCHIO 90° METRICO ISO 6149-3 CORPS: COUDE MALE 90° METRIQUE ISO 6149-3 BODY: ELBOW MALE COUPLING 90° METRIC ISO 6149-3 KÖRPER: WINKLEINSCHRAUBVERSCHRAUBUNG 90° METRISCH ISO 6149-3 CUERPO: CODO MACHO 90° METRICO ISO 6149-3		ST.07
CORPO: GOMITO MASCHIO 90° METRICO - RONDELLA TENUTA O-RING CORPS: COUDE MALE 90° METRIQUE - RONDELLE D'ETANCHEITE O-RING BODY: ELBOW MALE COUPLING 90° METRIC - O-RING SEAL RING KÖRPER: WINKLEINSCHRAUBVERSCHRAUBUNG 90° METRISCH - BEWEGLICHE UNTERLEGSCHIBE F.O-RING CUERPO: CODO MACHO 90° METRICO - ARANDELA DE RETENCION JUNTA TORICA		ST.07W
CORPO: UNIONE GOMITO 90° CON DADO GIREVOLE JIC CORPS: UNION COUDE 90° ECROU PIVOTANT JIC BODY: ELBOW COUPLING 90° WITH ROTARY NUT JIC KÖRPER: WINKELVERSCHRAUBUNG 90° MIT DREHMUTTER JIC CUERPO: CODO MACHO 90° CON TUERCA LOCA JIC		ST.09
CORPO: GOMITO MASCHIO 90° NPT - LUNGO CORPS: COUDE MALE 90° NPT - LONG BODY: ELBOW MALE COUPLING 90° NPT - LONG KÖRPER: WINKLEINSCHRAUBVERSCHRAUBUNG 90° MIT LANGEM SCHAFT-NPT CUERPO: CODO MACHO 90° NPT - PROLONGACIÓN		ST.10
CORPO: GOMITO MASCHIO 90° NPTF CORPS: COUDE MALE 90° NPTF BODY: ELBOW MALE COUPLING 90° NPTF KÖRPER: WINKLEINSCHRAUBVERSCHRAUBUNG 90° NPTF CUERPO: CODO MACHO 90° NPTF		ST.11
CORPO: GOMITO MASCHIO 90° BSPT CORPS: COUDE MALE 90° BSPT BODY: ELBOW MALE COUPLING 90° BSPT KÖRPER: WINKLEINSCHRAUBVERSCHRAUBUNG 90° BSPT CUERPO: CODO MACHO 90° BSPT		ST.12
CORPO: UNIONE PASSAPARATIA GOMITO 90° CORPS: UNION TRAVERSEE COUDE 90° BODY: BULKHEAD ELBOW 90° KÖRPER: WINKELSCHOTTVERSCHRAUBUNG 90° CUERPO: CODO PASATABIQUE CODO 90°		ST.13
CORPO: GOMITO 90° SILDABILE CORPS: COUDE 90° A SOUDER BODY: WELDING ELBOW 90° KÖRPER: ANSCHWEISSWINKEL 90° CUERPO: CODO 90° SOLDABLE		ST.15
CORPO: GOMITO 90° FEMMINA NPT CORPS: COUDE 90° FEMELLE NPT BODY: ELBOW 90° FEMALE NPT KÖRPER: WINKELVERSCHRAUBUNG 90° MUTTERSETTING NPT CUERPO: CODO 90° HEMBRA NPT		ST.17
CORPO: GOMITO MASCHIO 45° BSPP (GAS CILINDRICO) CORPS: COUDE MALE 45° BSPP (GAZ CYLINDRIQUE) BODY: ELBOW MALE COUPLING 45° BSPP (B.S.P. PARALLEL) KÖRPER: WINKLEINSCHRAUBVERSCHRAUBUNG 45° BSPP CUERPO: CODO MACHO 45° BSPP (GAS CILINDRICO)		ST.35



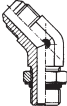

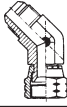
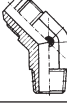
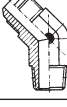
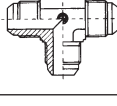
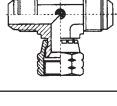
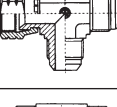
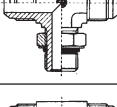
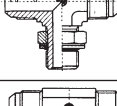
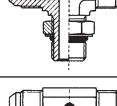
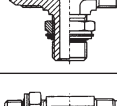
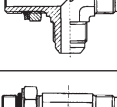
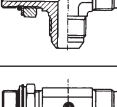
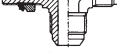



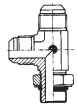
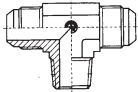
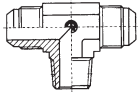
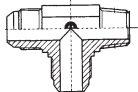
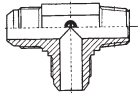
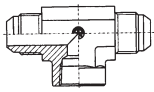
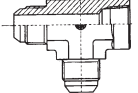
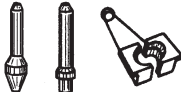

INDICE - INDEX

DESCRIZIONE - DESCRIPTION - BESCHREIBUNG - DESCRIPTION	CODICE - REFERENCE - CODE - BEST NR. - REFERENCIA	PAG.
CORPO: GOMITO MASCHIO 45° UNF 2A CORPS: COUDE MALE 45° UNF 2A BODY: ELBOW MALE COUPLING 45° UNF 2A KÖRPER: WINKELEINSCHRAUBVERSCHRAUBUNG 45° UNF 2A CUERPO: CODO MACHO 45° UNF 2A		ST.36
CORPO: GOMITO MASCHIO 45° METRICO - ISO 6149-3 CORPS: COUDE MALE 45° METRIQUE - ISO 6149-3 BODY: ELBOW MALE COUPLING 45° METRIC - ISO 6149-3 KÖRPER: WINKELEINSCHRAUBVERSCHRAUBUNG 45° METRISCH - ISO 6149-3 CUERPO: CODO MACHO 45° METRICO - ISO 6149-3		ST.37
CORPO: GOMITO MASCHIO 45° METRICO - RONDELLA TENUTA O-RING CORPS: COUDE MALE 45° METRIQUE - RONDELLE D'ETANCHEITE O-RING BODY: ELBOW MALE COUPLING 45° METRIC - O-RING SEAL RING KÖRPER: WINKELEINSCHRAUBVERSCHRAUBUNG 45° METRISCH - BEWEGLICHE UNTERLEGSCHIBE F.O-RING CUERPO: CODO MACHO 45° METRICO - ARANDELA DE RETENCION JUNTA TORICA		ST.37W
CORPO: UNIONE GOMITO 45° CON DADO GIREVOLE JIC CORPS: UNION COUDE 45° ECROU PIVOTANT JIC BODY: ELBOW COUPLING 45° WITH ROTARY NUT JIC KÖRPER: WINKELEINSCHRAUBVERSCHRAUBUNG 45° MIT DREHMUTTER JIC CUERPO: UNION CODO 45° CON TUERCA LOCA JIC		ST.39
CORPO: GOMITO MASCHIO 45° NPT CORPS: COUDE MALE 45° NPT BODY: ELBOW MALE COUPLING 45° NPT KÖRPER: WINKELEINSCHRAUBVERSCHRAUBUNG 45° NPT CUERPO: CODO MACHO 45° NPT		ST.41
CORPO: GOMITO MASCHIO 45° BSPT (GAS CONICO) CORPS: COUDE MALE 45° BSPT (GAZ CONIQUE) BODY: ELBOW MALE COUPLING 45° BSPT (BSP TAPERED) KÖRPER: WINKELEINSCHRAUBVERSCHRAUBUNG 45° BSPT CUERPO: CODO MACHO 45° BSPT (GAS CONICO)		ST.42
CORPO: UNIONE A "T" CORPS: UNION "T" BODY: EQUAL TEES KÖRPER: T-VERSCHRAUBUNG CUERPO: TE-MACHO MACHO		ST.51
CORPO: "T" DI LINEA CON DADO GIREVOLE JIC CORPS: "T" DE LIGNE - ECROU PIVOTANT JIC BODY: "T" OF LINE WITH ROTARY NUT JIC KÖRPER: LINIEN-T MIT DREHMUTTER JIC CUERPO: TE-MACHO FIJO TUERCA LOCA CENTRAL JIC		ST.55
CORPO: "T" DI DERIVAZIONE CON DADO GIREVOLE JIC CORPS: "T" DE DERIVATION - ECROU PIVOTANT JIC BODY: DERIVATING "T" WITH ROTARY NUT JIC KÖRPER: ABLEITUNG "T" MIT DREHMUTTER JIC CUERPO: TE-MACHO FIJO TUERCA LOCA LATERAL JIC		ST.59
CORPO: "T" MASCHIO DI LINEA UNF 2A CORPS: "T" MALE DE LIGNE UNF 2A BODY: "T" MALE LINE UNF 2A KÖRPER: LINIEN EINSCHRAUB-T UNF 2A CUERPO: TE-ORIENTABLE CENTRAL UNF 2A		ST.60
CORPO: "T" MASCHIO DI LINEA BSPP CORPS: "T" MALE DE LIGNE BSPP BODY: "T" MALE LINE BSPP KÖRPER: LINIEN EINSCHRAUB-TBSPP CUERPO: TE-ORIENTABLE CENTRAL BSPP		ST.61
CORPO: "T" MASCHIO DI LINEA METRICO - ISO 6149-3 CORPS: "T" MALE DE LIGNE METRIQUE - ISO 6149-3 BODY: "T" MALE LINE METRIC - ISO 6149-3 KÖRPER: LINIEN EINSCHRAUB-T METRISCH - ISO 6149-3 CUERPO: TE ORIENTABLE CENTRAL METRICO - ISO 6149-3		ST.62
CORPO: "T" MASCHIO DI LINEA METRICO - RONDELLA TENUTA O-RING CORPS: T MALE DE LIGNE METRIQUE - RONDELLE D'ETANCHEITE O-RING BODY: "T" MALE LINE METRIC - O-RING SEAL RING KÖRPER: LINIEN EINSCHRAUB-T METRISCH - BEWEGLICHE UNTERLEGSCHIBE F.O-RING CUERPO: TE ORIENTABLE CENTRAL METRICO - ARANDELA DE RETENCION JUNTA TORICA		ST.62W
CORPO: "T" MASCHIO DI DERIVAZIONE BSPP CORPS: "T" MALE DE DERIVATION BSPP BODY: DERIVATING "T" BSPP KÖRPER: ABLEITUNG "T" BSPP CUERPO: TE-ORIENTABLE LATERAL BSPP		ST.63
CORPO: "T" MASCHIO DI DERIVAZIONE METRICO - ISO 6149-3 CORPS: "T" MALE DE DERIVATION METRIQUE - ISO 6149-3 BODY: DERIVATING "T" METRIC - ISO 6149-3 KÖRPER: ABLEITUNG "T" METRISCH - ISO 6149-3 CUERPO: TE ORIENTABLE LATERAL METRICO - ISO 6149-3		ST.64
CORPO: "T" MASCHIO DI DERIVAZIONE METRICO - RONDELLA TENUTA O-RING CORPS: "T" MALE DE DERIVATION METRIQUE - RONDELLE D'ETANCHEITE O-RING BODY: DERIVATING "T" METRIC - O-RING SEAL RING KÖRPER: ABLEITUNG "T" METRISCH - BEWEGLICHE UNTERLEGSCHIBE F.O-RING CUERPO: TE ORIENTABLE LATERAL METRICO - ARANDELA DE RETENCION JUNTA TORICA		ST.64W



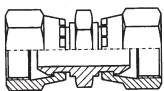

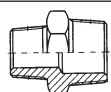
INDICE - INDEX

DESCRIZIONE - DESCRIPTION - BESCHREIBUNG - DESCRIPTION	CODICE - REFERENCE - CODE - BEST NR. - REFERENCIA	PAG.
CORPO: "T" MASCHIO DI DERIVAZIONE UNF 2A CORPS: "T" MALE DE DERIVATION UNF 2A BODY: DERIVATING "T" UNF 2A KÖRPER: ABLEITUNG "T" UNF 2A CUERPO: TE ORIENTABLE LATERAL UNF 2A		ST.65
CORPO: "T" MASCHIO DI LINEA NPT CORPS: "T" MALE DE LIGNE NPT BODY: "T" MALE LINE NPT KÖRPER: LINEN EINSCHRAUß T NPT CUERPO: TE MACHO CÓNICO NPT		ST.66
CORPO: "T" MASCHIO DI LINEA BSPT CORPS: "T" MALE DE LIGNE BSPT BODY: "T" MALE LINE BSPT KÖRPER: LINIEN EINSCHRAUß-T BSPT CUERPO: TE MACHO CÓNICO BSPT		ST.67
CORPO: "T" MASCHIO DI DERIVAZIONE NPT CORPS: "T" MALE DE DERIVATION NPT BODY: DERIVATING "T" NPT KÖRPER: ABLEITUNG "T" NPT CUERPO: TE MACHO DERIVACION NPT		ST.68
CORPO: "T" MASCHIO DI DERIVAZIONE BSPT (GAS CONICO) CORPS: "T" MALE DE DERIVATION BSPT (GAZ CONIQUE) BODY: DERIVATING "T" BSPT (BSP TAPERED) KÖRPER: ABLEITUNG-T BSPT (WITHWORTH-ROHRGEWINDE KEGELIG) CUERPO: TE MACHO DERIVACION BSPT (GAS CONICO)		ST.69
CORPO: "T" DI LINEA FEMMINA NPT CORPS: "T" MALE DE LIGNE FEMELLE NPT BODY: "T" MALE LINE FEMALE NPT KÖRPER: LINIEN EINSCHRAUß-T MUTTERSETTING NPT CUERPO: TE HEMBRA CENTRAL NPT		ST.71
CORPO: "T" DI DERIVAZIONE FEMMINA NPT CORPS: "T" MALE DE DERIVATION FEMELLE NPT BODY: DERIVATING "T" FEMALE NPT KÖRPER: ABLEITUNG "T" MUTTERSETTING NPT CUERPO: "T" DERIVACION HEMBRA NPT		ST.73
UTENSILI PER SVASARE OUTILS A EVASER FLARING TOOLS BORDELWERKZEUGE UTILES PARA ABOCARDAR		TN352 TN353 TN354 TN355
ADATTATORI - BSPP ADAPTATEURS - BSPP ADAPTORS - BSPP ADAPTER - BSPP ADAPTADORES - BSPP		34.00
ADATTATORI RIDOTTI BSPT ADAPTATEURS DE REDUCTION BSPT REDUCED ADAPTORS BSPT ADAPTER REDUZIERUNG BSPT ADAPTADORES REDUCIDO BSPT		34.01
ADATTATORI - BSPT ADAPTATEURS - BSPT ADAPTORS - BSPT ADAPTER - BSPT ADAPTADORES - BSPT		34.02
ADATTATORI RIDOTTI NPT ADAPTATEURS DE REDUCTION NPT REDUCED ADAPTORS NPT ADAPTER REDUZIERUNG NPT ADAPTADORES REDUCIDO NPT		34.03
ADATTATORI - NPT ADAPTATEURS - NPT ADAPTORS - NPT ADAPTER - NPT ADAPTADORES - NPT		34.04
ADATTATORE DIRITTO FEMMINA / FEMMINA DADO GIREVOLE ADAPTATEURS FEMELLE / FEMELLE ECROU PIVOTANT ADAPTORS - FEMALE/FEMALE WITH ROTARY NUT ADAPTER MUTTERSETTING MIT DREHMUTTER ADAPTADORES HEMBRA / HEMBRA CON TUERCA LOCA		34.11
ADATTATORE DIRITTO RIDOTTO FEMMINA / FEMMINA DADO GIREVOLE ADAPTATEURS DE REDUCTION FEMELLE / FEMELLE ECROU PIVOTANT REDUCED ADAPTORS - FEMALE / FEMALE WITH ROTARY NUT ADAPTER REDUZIERUNG MUTTERSETTING MIT BREHMUTTER ADAPTADORES REDUCIDO HEMBRA / HEMBRA CON TUERCA LOCA		34.12
NIPPLIO MASCHIO RIDOTTO FILETTATURA NPT/NPT UNION DOUBLE DE REDUCTION NPT/NPT REDUCED MALE NIPPLE - NPT/NPT THREAD GEWINDE ZAPFEN REDUZIERUNG NPT/NPT GEWINDE ENLACE MACHO - REDUCIDO RECTO ROSCA NPT/NPT		34.57

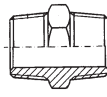
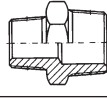
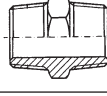
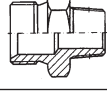
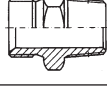
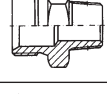
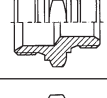
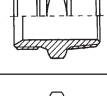
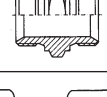
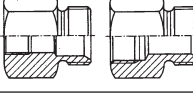

INDICE - INDEX

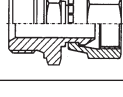
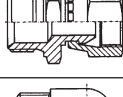
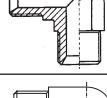
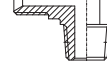
DESCRIZIONE - DESCRIPTION - BESCHREIBUNG - DESCRIPTION	CODICE - REFERENCE - CODE - BEST NR. - REFERENCIA	PAG.
NIPPLO MASCHIO DI ESTREMITÀ DIRITTO FILETTATURA NPT/NPT UNION SIMPLE NPT/NPT MALE NIPPLE STUD COUPLING - NPT/NPT THREAD GEWINDE ZAPFEN NPT/NPT GEWINDE ENLACE MACHO - RECTO ROSCA NPT/NPT		34.58
NIPPLO MASCHIO RIDOTTO FILETTATURA GAS CONICA BSPT UNION DOUBLE DE REDUCTION BSPT REDUCED MALE NIPPLE - STRAIGHT COUPLING BSPT GEWINDE ZAPFEN REDUZIERUNG BSPT KONISCH GEWINDE ENLACE MACHO - REDUCIDO RECTO ROSCA BSPT		34.59
NIPPLO MASCHIO DI ESTREMITÀ DIRITTO BSPT UNION SIMPLE BSPT MALE NIPPLE STUD COUPLING BSPT THREAD GEWINDEZAPFEN BSPT GEWINDE ENLACE MACHO - RECTO ROSCA BSPT		34.60
NIPPLO MASCHIO RIDOTTO BSPP/NPT UNION DOUBLE DE REDUCTION BSPP/NPT REDUCED MALE NIPPLE STRAIGHT BSPP/NPT GEWINDEZAPFEN REDUZIERUNG BSPP/NPT ENLACE MACHO - REDUCIDO RECTO ROSCA BSPP/NPT		34.64
NIPPLO MASCHIO DI ESTREMITÀ DIRITTO BSPP/NPT UNION SIMPLE BSPP/NPT MALE NIPPLE STUD COUPLING BSPP/NPT GEWINDEZAPFEN BSP GEWINDE ZYLINDRISCH/NPT ENLACE MACHO - RECTO ROSCA GAS CILINDRICA BSPP/NPT		34.65
NIPPLO MASCHIO RIDOTTO BSPP/BSPT UNION DOUBLE DE REDUCTION BSPP/BSPT REDUCED MALE NIPPLE STRAIGHT COUPLING BSPP/BSPT GEWINDEZAPFEN REDUZIERUNG BSPP/BSPT ENLACE MACHO - REDUCIDO RECTO ROSCA BSPP/BSPT		34.66
NIPPLO MASCHIO RIDOTTO - INTERMEDIO DIRITTO BSPP UNION DOUBLE DE REDUCTION BSPP REDUCED MALE NIPPLE - STRAIGHT COUPLING BSPP GEWINDEZAPFEN REDUZIERUNG B.S.P GEWINDE ZYLINDRISCH ENLACE MACHO - REDUCIDO RECTO ROSCA GAS CILINDRICA		34.67
NIPPLO MASCHIO - DI ESTREMITÀ DIRITTO BSPP/BSPT UNION SIMPLE BSPP-BSPT MALE NIPPLE - STUD COUPLING - BSP PARALLEL - BSP TAPARED GEWINDEZAPFEN BSP ZYLINDRISCH BSP KONISCH ENLACE MACHO - RECTO ROSCA GAS CILINDRICA - GAS CONICA		34.68
NIPPLO MASCHIO - INTERMEDIO DIRITTO BSPP UNION DOUBLE BSPP MALE NIPPLE - STRAIGHT COUPLING - BSP PARALLEL THREAD GEWINDEZAPFEN BSPP ENLACE MACHO - RECTO ROSCA GAS CILINDRICO		34.69
RIDUZIONE BSPP CONO 60° INTERMEDIAIRE DE REDUCTION BSPP SURFACE 60° STUD ADAPTORS BSPP CONED 60° BSPP REDUZIERUNG / ERWEITERUNG MIT 60° - KONUS RACOR DE REDUCCIÓN ROSCADO BSPP ASIENTO 60°		34.73
TAPPO MASCHIO OBTURATEUR MALE MALE PLUG VERSCHLUSS BUTZEN TAPÓN MACHO		34.75
TAPPO FEMMINA OBTURATEUR FEMELLE FEMALE PLUG VERSCHLUSS KAPPE TAPÓN HEMBRA		34.76
ADATTATORE DIRITTO MASCHIO GAS CIL. 60° - FEMMINA GIREVOLE 60° ADAPTEUR DROIT FBSPP 60° - HBSPP 60° STRAIGHT ADAPTER MALE BSPP CONED 60° - FEMALE CAP SURFACE 60° AUSSENGEWINDE ÜBERWURFMUTTER BSPP ADAPTER ADAPTADOR MACHO TUERCA ROSCA GAS ASIENTO 60°		600.01
ADATTATORE DIRITTO RIDOTTO MASCHIO GAS CIL. 60° - FEMMINA GIREVOLE 60° ADAPTEUR DE REDUCTION DROIT FBSPP 60° - HBSPP 60° REDUCED STRAIGHT ADAPTER MALE BSPP CONED 60° - FEMALE CAP SURFACE 60° AUSSENGEWINDE ÜBERWURFMUTTER BSPP ADAPTER REDUZIERUNG ADAPTADOR REDUCIDO MACHO TUERCA ROSCA GAS ASIENTO 60°		600.02
UNIONE GOMITO 90° UNIONE CODE 90° ELBOW COUPLING 90° WINKELVERSCHRAUBUNG 90° UNION CODO MACHO 90°		60.01
UNIONE GOMITO 90° GAS CILINDRICO - GAS CONICO UNIONE CODE 90° CYLINDRIQUE - GAZ CONIQUE ELBOW COUPLING 90° BSPP - BSPT WINKELVERSCHRAUBUNG 90° BSPP - BSPT UNION CODO MACHO 90° BSPP - BSPT		60.02

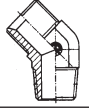
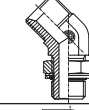
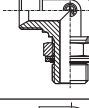
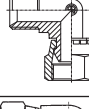
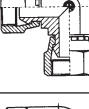
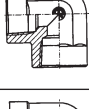
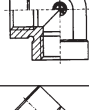
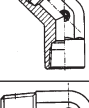
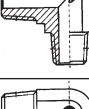
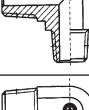
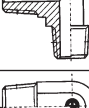
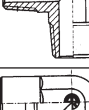
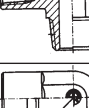
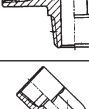
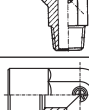
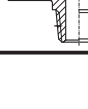

INDICE - INDEX

DESCRIZIONE - DESCRIPTION - BESCHREIBUNG - DESCRIPTION	CODICE - REFERENCE - CODE - BEST NR. - REFERENCIA	PAG.
GOMITO MASCHIO 45° GAS CILINDRICO - GAS CONICO COUDE MALE 45° GAZ CYLINDRIQUE - GAZ CONIQUE ELBOW MALE COUPLING 45° BSPP - BSPT WINKLEINSCHRAUBVERSCHRAUBUNG 45° BSPP - BSPT CODO MACHO 45° BSPP - BSPT		60.03 81
ADATTATORE ORIENTABILE 45° MASCHIO-MASCHIO CON O.RING COUDE ORIENTABLE 45° MALE-MALE AVEC O.RING 45° MALE-MALE O.RING ADJUSTABLE ADAPTOR 45° EINSTELLBARER EINSCHRAUBADAPTER MIT O.RING CUERPO: ADAPTADOR ORIENTABLE 45° MACHO-MACHO CON JUNTA TORICA		60.04 82
ADATTATORE ORIENTABILE 90° MASCHIO-MASCHIO CON O.RING COUDE ORIENTABLE 90° MALE-MALE AVEC O.RING 90° MALE-MALE O.RING ADJUSTABLE ADAPTOR 90° EINSTELLBARER EINSCHRAUBADAPTER MIT O.RING CUERPO: ADAPTADOR ORIENTABLE 90° MACHO-MACHO CON JUNTA TORICA		60.05 83
UNIONE GOMITO 90° CON DADO GIREVOLE UNION COUDE 90° ECROU PIVOTANT ELBOW COUPLING 90° WITH ROTARY NUT WINKELVERSCHRAUBUNG 90° MIT DREHMUTTER UNION CODO 90° CON TUERCA LOCA		60.09 83
UNIONE GOMITO 90° CON DADO GIREVOLE UNION COUDE 90° ECROU PIVOTANT ELBOW COUPLING 90° WITH ROTARY NUT WINKELVERSCHRAUBUNG 90° MIT DREHMUTTER UNION CODO 90° CON TUERCA LOCA		60.10 83
UNIONE GOMITO 90° FEMMINA NPT UNION COUDE 90° FEMELLE NPT ELBOW FEMALE COUPLING 90° WINKELAUFSCHRAUBVERSCHRAUBUNG 90° NPT UNION CODO 90° HEMBRA NPT		60.14 84
UNIONE GOMITO 90° FEMMINA BSPP UNION COUDE 90° FEMELLE BSPP ELBOW FEMALE COUPLING 90° BSPP WINKELVERSCHRAUBVERSCHRAUBUNG 90° BSPP UNION CODO 90° HEMBRA BSPP		60.15 84
UNIONE GOMITO 45° FEMMINA NPT UNION COUDE 45° FEMELLE NPT ELBOW FEMALE COUPLING 45° NPT WINKELVERSCHRAUBVERSCHRAUBUNG 45° NPT UNION CODO 45° HEMBRA NPT		60.16 84
GOMITO MASCHIO RIDOTTO 90° BSPT COUDE MALE DE REDUCTION 90° BSPT REDUCED ELBOW MALE COUPLING 90° BSPT WINKELVERSCHRAUBVERSCHRAUBUNG 90° BSPT CODO MACHO REDUCIDO 90° BSPT		60.19 85
GOMITO MASCHIO 90° BSPT COUDE MALE 90° BSPT MALE COUPLING 90° BSPT WINKELVERSCHRAUBVERSCHRAUBUNG 90° BSPT CODO MACHO 90° BSPT		60.20 85
GOMITO MASCHIO RIDOTTO 90° NPT COUDE MALE DE REDUCTION 90° NPT REDUCED ELBOW MALE COUPLING 90° NPT WINKELVERSCHRAUBVERSCHRAUBUNG 90° NPT CODO MACHO REDUCIDO 90° NPT		60.21 86
GOMITO MASCHIO 90° NPT COUDE MALE 90° NPT MALE COUPLING 90° NPT WINKELVERSCHRAUBVERSCHRAUBUNG 90° NPT CODO MACHO 90° NPT		60.22 86
GOMITO RIDOTTO MASCHIO FEMMINA 90° NPT COUDE DE REDUCTION MALE FEMELLE 90° NPT REDUCED ELBOW MALE FEMALE 90° NPT WINKELVERSCHRAUBVERSCHRAUBUNG 90° NPT CODO MACHO HEMBRA 90° NPT		60.25 86
GOMITO MASCHIO FEMMINA 90° NPT COUDE MALE FEMELLE 90° NPT ELBOW MALE FEMALE 90° NPT WINKELVERSCHRAUBVERSCHRAUBUNG 90° NPT CODO MACHO HEMBRA 90° NPT		60.26 87
GOMITO MASCHIO FEMMINA 45° NPT COUDE MALE FEMELLE 45° NPT ELBOW MALE FEMALE 45° NPT WINKELVERSCHRAUBVERSCHRAUBUNG 45° NPT CODO MACHO HEMBRA 45° NPT		60.27 87
GOMITO RIDOTTO MASCHIO BSPT FEMMINA BSPP 90° COUDE DE REDUCTION MALE BSPT FEMELLE BSPP 90° REDUCED ELBOW MALE BSPT FEMALE BSPP 90° WINKELVERSCHRAUBVERSCHRAUBUNG 90° BSPT/BSPP CODO MACHO BSPT HEMBRA BSPP 90°		60.35 87

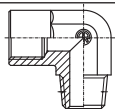
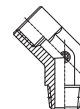
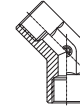
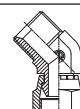
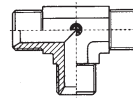
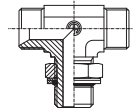
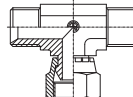
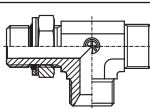
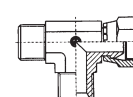
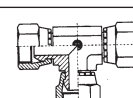
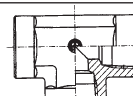
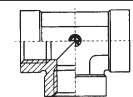
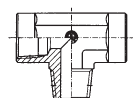
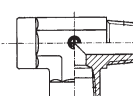
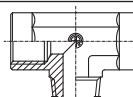
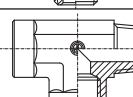

INDICE - INDEX

DESCRIZIONE - DESCRIPTION - BESCHREIBUNG - DESCRIPTION	CODICE - REFERENCE - CODE - BEST NR. - REFERENCIA	PAG.
GOMITO MASCHIO BSPT FEMMINA BSPP 90° COUDE MALE BSPT FEMELLE BSPP 90° ELBOW MALE BSPT FEMALE BSPP 90° VERSCHRAUBVERSCHRAUBUNG 90° BSPT/BSPPMACHO BSPT HEMBRA BSPP 90°	 60.36	87
GOMITO MASCHIO BSPT FEMMINA BSPP 45° COUDE MALE BSPT FEMELLE BSPP 45° ELBOW MALE BSPT FEMALE BSPP 45° WINKELVERSCHRAUBVERSCHRAUBUNG 45° BSPT/BSPP CODO MACHO BSPT HEMBRA BSPP 45°	 60.37	88
UNIONE GOMITO 45° FEMMINA BSPP UNION COUDE 45° FEMELLE BSPP ELBOW FEMALE COUPLING 45° BSPP WINKELVERSCHRAUBVERSCHRAUBUNG 45° BSPP UNION CODO 45° HEMBRA BSPP	 60.38	
UNIONE GOMITO 45° CON DADO GIREVOLE UNION COUDE 45° ECROU PIVOTANT ELBOW COUPLING 45° WITH ROTARY NUT WINKELVERSCHRAUBUNG 45° MIT DREHMUTTER UNION CODO 45° CON TUERCA LOCA	 60.39	
UNIONE A "T" UNION "T" EQUAL TEES T-VERSCHRAUBUNG UNION TE MACHO-MACHO	 60.51	89
ADATTATORE ORIENTABILE A "T" MASCHIO-MASCHIO CON O.RING COUDE ORIENTABLE "T" MALE-MALE AVEC O.RING "T" MALE-MALE O.RING ADJUSTABLE ADAPTOR "T" EINSTELLBARER EINSCHRAUBADAPTER MIT O.RING ADAPTADOR ORIENTABLE "T" MACHO-MACHO CON JUNTA TORICA	 60.53	
"T" DI LINEA CON DADO GIREVOLE "T" DE LIGNE ECROU PIVOTANT "T" OF LINE WITH ROTARY NUT LINIEN T MIT DREHMUTTER TE MACHO TUERCA LOCA CENTRAL	 60.55	90
ADATTATORE ORIENTABILE A "L" MASCHIO-MASCHIO CON O.RING COUDE ORIENTABLE "L" MALE-MALE AVEC O.RING ADJUSTABLE ADAPTOR "L" MALE-MALE O.RING "L" EINSTELLBARER EINSCHRAUBADAPTER MIT O.RING ADAPTADOR ORIENTABLE "L" MACHO-MACHO CON JUNTA TORICA	 60.57	
"T" DI DERIVAZIONE CON DADO GIREVOLE "T" DE DERIVATION ECROU PIVOTANT DERIVATING "T" WITH ROTARY NUT ABLEITUNG-T MIT DREHMUTTER TE MACHO TUERCA LOCA LATERAL	 60.59	91
UNIONE A "T" CON DADO GIREVOLE UNION "T" ECROU PIVOTANT EQUAL TEES WITH ROTARY NUT T-VERSCHRAUBUNG MIT DREHMUTTER UNION TE CON TUERCA LOCA	 60.60	
"T" FEMMINA NPT "T" FEMELLE NPT FEMALE "T" NPT AUFSCHRAUB-T NPT TE HEMBRA NPT	 60.64	
"T" FEMMINA BSPP "T" FEMELLE BSPP FEMALE "T" BSPP AUFSCHRAUB-T BSPP TE HEMBRA BSPP	 60.65	92
"T" DI DERIVAZIONE MASCHIO/FEMMINA NPT "T" MALE/FEMELLE DE DERIVATION NPT DERIVATING "T" MALE/FEMALE NPT ABLEITUNG "T" - NPT TE MACHO/HEMBRA DERIVACION NPT	 60.67	
"L" DI DERIVAZIONE MASCHIO/FEMMINA NPT "L" MALE/FEMELLE DE DERIVATION NPT DERIVATING "L" MALE/FEMALE NPT ABLEITUNG "L" - NPT TE MACHO/HEMBRA DERIVACION NPT	 60.68	
"T" DI DERIVAZIONE MASCHIO BSPT FEMMINA BSPP "T" MALE BSPT FEMELLE BSPP DE DERIVATION DERIVATING "T" MALE BSPT FEMALE BSPP ABLEITUNG "T" - BSPT/BSPP TE MACHO BSPT HEMBRA BSPP DERIVACION	 60.77	93
"L" DI DERIVAZIONE MASCHIO BSPT FEMMINA BSPP "L" MALE BSPT FEMELLE BSPP DE DERIVATION DERIVATING "L" MALE BSPT FEMALE BSPP ABLEITUNG "L" - BSPT/BSPP TE MACHO BSPT HEMBRA BSPP DERIVACION	 60.78	



DADO
ECROU
NUT
ÜBERWURFMUTTER
TUERCA

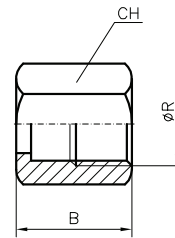

Ø TUBO-TUBE-ROHR		CODICE REFERENCE CODE BEST.-NR. REFERENCIA	Ø R-UNF JIC 37°	B	CH	
mm.	Poll. - Pouces Inch. - Zoll Pulgadas					
6	1/4	● BA.13.00.04	7/16	15,5	14	
8	5/16	● BA.13.00.05	1/2	17	17	
10	3/8	● BA.13.00.06	9/16	18,3	19	
12	1/2	● BA.13.00.08	3/4	21,3	22	
14	-	● BA.13.00.10	7/8	24,6	27	
15	-	● BA.13.00.10	7/8	24,6	27	
16	5/8	● BA.13.00.10	7/8	24,6	27	
18	3/4	● BA.13.00.12	1" 1/16	25,9	32	
20	-	● BA.13.00.14	1"1/16	25,9	32	
25	1"	● BA.13.00.16	1" 5/16	28,4	41	
30	-	● BA.13.00.20	1" 5/8	31	50	
32	1" 1/4	● BA.13.00.20	1" 5/8	31	50	
38	1" 1/2	● BA.13.00.24	1" 7/8	35,8	60	

BUSSOLA: TUBO POLLICI
TUBO METRICO
FOURREAU: TUBE POUCES
TUBE METRIQUE
BUSH: INCHES TUBE
METRIC TUBE
STÜTZHÜLSE: METRISCHES ROHR
ZÖLLIGES ROHR
FERULA: TUBO EN PULGADAS
TUBO METRICO

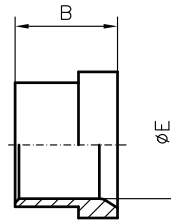

Ø TUBO-TUBE-ROHR		CODICE REFERENCE CODE BEST.-NR. REFERENCIA	B	Ø E	
mm.	Poll. - Pouces Inch. - Zoll Pulgadas				
-	1/4	● BA.15.00.04	10,4	6,55	
-	5/16	● BA.15.00.05	11,2	8,15	
-	3/8	● BA.15.00.06	12,7	9,75	
-	1/2	● BA.15.00.08	14,2	12,90	
-	5/8	● BA.15.00.10	16,8	16,10	
-	3/4	● BA.15.00.12	17,3	19,25	
-	1"	● BA.15.00.16	19,8	25,60	
-	1" 1/4	● BA.15.00.20	23,1	32,10	
-	1" 1/2	● BA.15.00.24	28,4	38,45	
6	-	● BA.83.00.06	10,4	6,13	
8	-	● BA.83.00.08	11,2	8,13	
10	-	● BA.83.00.10	12,7	10,13	
12	-	● BA.83.00.12	14,2	12,13	
14	-	● BA.83.00.14	16,8	14,15	
15	-	● BA.83.00.15	16,8	15,15	
16	-	● BA.83.00.16	16,8	16,15	
18	-	● BA.83.00.18	17,3	18,15	
20	-	● BA.83.00.20	17,3	20,15	
25	-	● BA.83.00.25	19,8	25,15	
30	-	● BA.83.00.30	23,1	30,15	
32	-	● BA.83.00.32	23,1	32,25	
38	-	● BA.83.00.38	28,4	38,35	



CORPO: UNIONE DIRITTA
CORPS: UNION DROIT
BODY: STRAIGHT COUPLING
KÖRPER: GERADE VERSCHRAUBUNG
CUERPO: ADAPTADOR RECTO

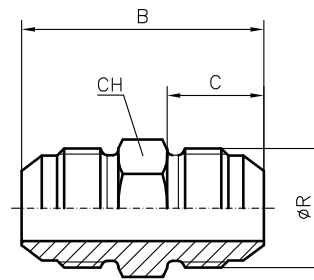

Ø TUBO-TUBE-ROHR		CODICE REFERENCE CODE BEST.-NR. REFERENCIA	Ø R-UNF JIC 37°	B	C	CH	PN	
mm.	Poll. - Pouces Inch. - Zoll Pulgadas							
6	1/4	● BA.17.00.04	7/16	34,8	14	13 1)	350	
8	5/16	● BA.17.00.05	1/2	34,8	14	14	350	
10	3/8	● BA.17.00.06	9/16	35,8	14,1	16 2)	350	
12	1/2	● BA.17.00.08	3/4	41,1	16,7	19	350	
14	-	● BA.17.00.10	7/8	47,8	19,3	24	350	
15	-	● BA.17.00.10	7/8	47,8	19,3	24	350	
16	5/8	● BA.17.00.10	7/8	47,8	19,3	24	350	
18	-	● BA.17.00.12	1" 1/16	54,9	21,9	27	350	
20	3/4	● BA.17.00.12	1" 1/16	54,9	21,9	27	350	
25	1"	● BA.17.00.16	1" 5/16	57,2	23,1	36	280	
30	-	● BA.17.00.20	1" 5/8	61,7	24,3	46	210	
32	1" 1/4	● BA.17.00.20	1" 5/8	61,7	24,3	46	210	
38	1" 1/2	● BA.17.00.24	1" 7/8	69,8	27,5	50	140	

1) AISI 316L CH = 12 2) AISI 316L CH = 17

CORPO: UNIONE DIRITTA RIDOTTA
CORPS: UNION DROIT DE REDUCTION
BODY: REDUCED STRAIGHT COUPLING
KÖRPER: GERADE VERSCHRAUBUNG - REDUZIERUNG
CUERPO: ADAPTADOR REDUCIDO RECTO

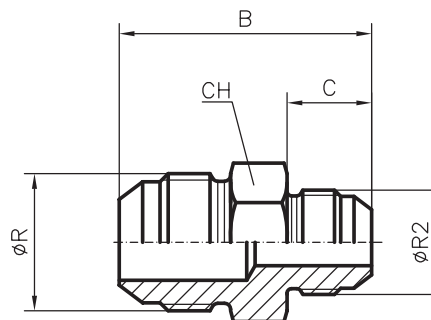

Ø TUBO-TUBE-ROHR		CODICE REFERENCE CODE BEST.-NR. REFERENCIA	Ø R-UNF JIC 37°	Ø R2-UNF JIC 37°	B	C	C2	CH	PN
mm.	Poll. - Pouces Inch. - Zoll Pulgadas								
10	3/8	● BA.18.06.04	9/16	7/16	35,7	14,1	14	16 1)	350
12	1/2	● BA.18.08.06	3/4	9/16	38,5	16,7	14,1	19	350
14	-	● BA.18.10.08	7/8	3/4	45,2	19,3	16,7	24	350
15	-	● BA.18.10.08	7/8	3/4	45,2	19,3	16,7	24	350
16	5/8	● BA.18.10.08	7/8	3/4	45,2	19,3	16,7	24	350
18	-	● BA.18.12.08	1" 1/16	3/4	49,7	21,9	16,7	27	350
20	3/4	● BA.18.12.08	1" 1/16	3/4	49,7	21,9	16,7	27	350
18	-	● BA.18.12.10	1" 1/16	7/8	52,3	21,9	19,3	27	350
20	3/4	● BA.18.12.10	1" 1/16	7/8	52,3	21,9	19,3	27	350
25	1"	● BA.18.16.12	1" 5/16	1"1/16	56	23,1	21,9	36	280

1) AISI 316L CH = 17



CORPO: TERMINALE DIRITTO MASCHIO BSPP (GAS CILINDRICO)
CORPS: TERMINAL DROIT MALE BSPP (GAZ CYLINDRIQUE)
BODY: MALE STUD BSPP (B.S.P. PARALLEL)
KÖRPER: GERADE EINSCHRAUB BSPP (B.S.P. ZYLINDRISCH)
CUERPO: ADAPTADOR RECTO MACHO BSPP (GAS CILINDRICO)

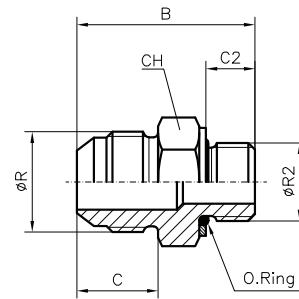

Ø TUBO-TUBE-ROHR		CODICE REFERENCE CODE BEST.-NR. REFERENCIA	Ø R-UNF JIC 37°	Ø R2 BSPP	B	C	C2	CH	PN
mm.	Poll. - Pouces Inch. - Zoll Pulgadas								
6	1/4	● BA.19.04.02	7/16	1/8	28,7	14	6,3	16 1)	350
6	1/4	● BA.19.04.04	7/16	1/4	32	14	9,5	19	350
6	1/4	● BA.19.04.06	7/16	3/8	33	14	9,5	22	350
6	1/4	● BA.19.04.08	7/16	1/2	38,6	14	13	30	350
8	5/16	● BA.19.05.02	1/2	1/8	28,7	14	6,3	16 1)	350
8	5/16	● BA.19.05.04	1/2	1/4	32	14	9,5	19	350
8	5/16	● BA.19.05.06	1/2	3/8	33,7	14	9,5	22	350
10	3/8	● BA.19.06.02	9/16	1/8	28,7	14,1	6,3	16 1)	350
10	3/8	● BA.19.06.04	9/16	1/4	32	14,1	9,5	19	350
10	3/8	● BA.19.06.06	9/16	3/8	33	14,1	9,5	22	350
10	3/8	● BA.19.06.08	9/16	1/2	38,6	14,1	13	30	350
12	1/2	● BA.19.08.04	3/4	1/4	35	16,7	9,5	19	350
12	1/2	● BA.19.08.06	3/4	3/8	36	16,7	9,5	22	350
12	1/2	● BA.19.08.08	3/4	1/2	41,4	16,7	13	30	350
12	1/2	● BA.19.08.12	3/4	3/4	42,4	16,7	13	36	250
14	-	● BA.19.10.06	7/8	3/8	39,1	19,3	9,5	24	350
15	-	● BA.19.10.06	7/8	3/8	39,1	19,3	9,5	24	350
16	5/8	● BA.19.10.06	7/8	3/8	39,1	19,3	9,5	24	350
14	-	● BA.19.10.08	7/8	1/2	43,9	19,3	13	30	350
15	-	● BA.19.10.08	7/8	1/2	43,9	19,3	13	30	350
16	5/8	● BA.19.10.08	7/8	1/2	43,9	19,3	13	30	350
14	-	● BA.19.10.12	7/8	3/4	43,9	19,3	13	36	250
15	-	● BA.19.10.12	7/8	3/4	43,9	19,3	13	36	250
16	5/8	● BA.19.10.12	7/8	3/4	43,9	19,3	13	36	250
18	-	● BA.19.12.06	1" 1/16	3/8	42,4	21,9	9,5	30	350
20	3/4	● BA.19.12.06	1" 1/16	3/8	42,4	21,9	9,5	30	350
18	-	● BA.19.12.08	1" 1/16	1/2	46,7	21,9	13	30	350
20	3/4	● BA.19.12.08	1" 1/16	1/2	46,7	21,9	13	30	350
18	-	● BA.19.12.12	1" 1/16	3/4	47,5	21,9	13	36	250
20	3/4	● BA.19.12.12	1" 1/16	3/4	47,5	21,9	13	36	250
18	-	● BA.19.12.16	1" 1/16	1"	52,6	21,9	16	46	250
20	3/4	● BA.19.12.16	1" 1/16	1"	52,6	21,9	16	46	250
25	1"	● BA.19.16.12	1" 5/16	3/4	48,5	23,1	13	36	250
25	1"	● BA.19.16.16	1" 5/16	1"	53,6	23,1	16	46	250
25	1"	● BA.19.16.20	1" 5/16	1" 1/4	55,1	23,1	16	50	175
25	1"	● BA.19.16.24	1" 5/16	1" 1/2	55,7	23,1	16	60	175
30	-	● BA.19.20.16	1" 5/8	1"	53,6	24,3	16	46	210
32	1" 1/4	● BA.19.20.16	1" 5/8	1"	53,6	24,3	16	46	210
30	-	● BA.19.20.20	1" 5/8	1" 1/4	56,9	24,3	16	50	175
32	1" 1/4	● BA.19.20.20	1" 5/8	1" 1/4	56,9	24,3	16	50	175
30	-	● BA.19.20.24	1" 5/8	1" 1/2	56,8	24,3	16	55	140
32	1" 1/4	● BA.19.20.24	1" 5/8	1" 1/2	56,8	24,3	16	55	140
38	1" 1/2	● BA.19.24.16	1" 7/8	1"	57,5	27,5	16	50	140
38	1" 1/2	● BA.19.24.20	1" 7/8	1" 1/4	60,4	27,5	16	50	140
38	1" 1/2	● BA.19.24.24	1" 7/8	1" 1/2	61	27,5	16	60	140

1) AISI 316L CH = 17



- CORPO: TERMINALE DIRITTO MASCHIO BSPP (GAS CILINDRICO)
GG - GUARNIZIONE GOMMA - FORMA E DIN 3852
- CORPS: TERMINAL DROIT MALE BSPP (GAZ CYLINDRIQUE)
GG - JOINT EN CAOUTCHOUC - FORME E DIN 3852
- BODY: MALE STUD BSPP (B.S.P. PARALLEL)
GG - RUBBER SEAL - TYPE E DIN 3852
- KÖRPER: GERADE EINSCHRAUB BSPP (B.S.P. ZYLINDRISCH)
GG - GUMMIDICHTUNG - FORM E DIN 3852
- CUERPO: ADAPTADOR RECTO MACHO BSPP (GAS CILINDRICO)
GG - JUNTA DE GOMA - FORMA E DIN 3852

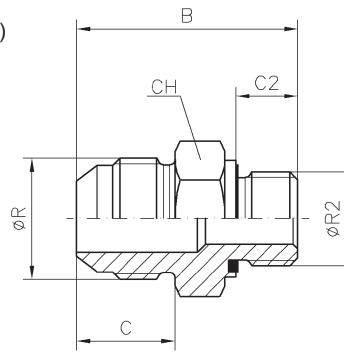

Ø TUBO-TUBE-ROHR		CODICE REFERENCE CODE BEST.-NR. REFERENCIA	Ø R-UNF JIC 37°	Ø R2 BSPP	B	C	C2	CH	PN
mm.	Poll. - Pouces Inch. - Zoll Pulgadas								
6	1/4	● BA.20.04.02	7/16	1/8	30	14	8	14	350
6	1/4	● BA.20.04.04	7/16	1/4	35	14	12	19	350
6	1/4	● BA.20.04.06	7/16	3/8	35,5	14	12	22	350
6	1/4	● BA.20.04.08	7/16	1/2	39	14	14	27	350
8	5/16	● BA.20.05.02	1/2	1/8	30	14	8	14	350
8	5/16	● BA.20.05.04	1/2	1/4	35	14	12	19	350
8	5/16	● BA.20.05.06	1/2	3/8	35,7	14	12	22	350
10	3/8	● BA.20.06.02	9/16	1/8	31	14,1	8	16 1)	350
10	3/8	● BA.20.06.04	9/16	1/4	35	14,1	12	19	350
10	3/8	● BA.20.06.06	9/16	3/8	36	14,1	12	22	350
10	3/8	● BA.20.06.08	9/16	1/2	39,5	14,1	14	27	350
12	1/2	● BA.20.08.04	3/4	1/4	38,5	16,7	12	19	350
12	1/2	● BA.20.08.06	3/4	3/8	39	16,7	12	22	350
12	1/2	● BA.20.08.08	3/4	1/2	42	16,7	14	27	350
12	1/2	● BA.20.08.12	3/4	3/4	45,5	16,7	16	32	250
14	-	● BA.20.10.06	7/8	3/8	42,5	19,3	12	24	350
15	-	● BA.20.10.06	7/8	3/8	42,5	19,3	12	24	350
16	5/8	● BA.20.10.06	7/8	3/8	42,5	19,3	12	24	350
14	-	● BA.20.10.08	7/8	1/2	44,5	19,3	14	27	350
15	-	● BA.20.10.08	7/8	1/2	44,5	19,3	14	27	350
16	5/8	● BA.20.10.08	7/8	1/2	44,5	19,3	14	27	350
14	-	● BA.20.10.12	7/8	3/4	48	19,3	16	32	250
15	-	● BA.20.10.12	7/8	3/4	48	19,3	16	32	250
16	5/8	● BA.20.10.12	7/8	3/4	48	19,3	16	32	250
18	-	● BA.20.12.06	1" 1/16	3/8	45,5	21,9	12	27	350
20	3/4	● BA.20.12.06	1" 1/16	3/8	45,5	21,9	12	27	350
18	-	● BA.20.12.08	1" 1/16	1/2	49	21,9	14	27	350
20	3/4	● BA.20.12.08	1" 1/16	1/2	49	21,9	14	27	350
18	-	● BA.20.12.12	1" 1/16	3/4	51	21,9	16	32	250
20	3/4	● BA.20.12.12	1" 1/16	3/4	51	21,9	16	32	250
18	-	● BA.20.12.16	1" 1/16	1"	53,5	21,9	18	41	250
20	3/4	● BA.20.12.16	1" 1/16	1"	53,5	21,9	18	41	250
25	1"	● BA.20.16.12	1" 5/16	3/4	52,5	23,1	16	36	250
25	1"	● BA.20.16.16	1" 5/16	1"	54,5	23,1	18	41	250
25	1"	● BA.20.16.20	1" 5/16	1" 1/4	58,5	23,1	20	50	175
25	1"	● BA.20.16.24	1" 5/16	1" 1/2	62	23,1	22	55	175
30	-	● BA.20.20.16	1" 5/8	1"	56	24,3	18	46	210
32	1" 1/4	● BA.20.20.16	1" 5/8	1"	56	24,3	18	46	210
30	-	● BA.20.20.20	1" 5/8	1" 1/4	60	24,3	20	50	175
32	1" 1/4	● BA.20.20.20	1" 5/8	1" 1/4	60	24,3	20	50	175
30	-	● BA.20.20.24	1" 5/8	1" 1/2	63,8	24,3	22	55	140
32	1" 1/4	● BA.20.20.24	1" 5/8	1" 1/2	63,8	24,3	22	55	140
38	1" 1/2	● BA.20.24.16	1" 7/8	1"	60	27,5	18	50	140
38	1" 1/2	● BA.20.24.20	1" 7/8	1" 1/4	65	27,5	20	50	140
38	1" 1/2	● BA.20.24.24	1" 7/8	1" 1/2	67	27,5	22	55	140

1) AISI 316L CH = 17



CORPO: TERMINALE DIRITTO MASCHIO UNF 2A

CORPS: TERMINAL DROIT MALE UNF 2A

BODY: MALE STUD UNF 2A

KÖRPER: GERADE EINSCHRAUB UNF 2A

CUERPO: ADAPTADOR RECTO MACHO UNF 2A

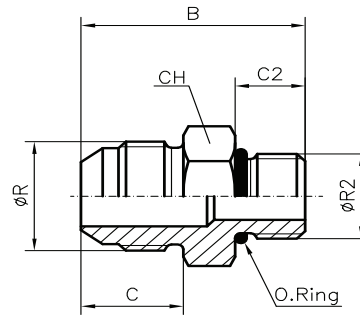

Ø TUBO-TUBE-ROHR		CODICE REFERENCE CODE BEST.-NR. REFERENCIA	Ø R-UNF JIC 37°	Ø R2 UNF	B	C	C2	CH	PN
mm.	Poll. - Pouces Inch. - Zoll Pulgadas								
6	1/4	● BA.21.04.04	7/16	7/16	31,2	14	9,1	14	350
6	1/4	● BA.21.04.05	7/16	1/2	31,2	14	9,1	16 1)	350
6	1/4	● BA.21.04.06	7/16	9/16	33	14	9,9	17	350
6	1/4	● BA.21.04.08	7/16	3/4	35	14	11,1	22	350
8	5/16	● BA.21.05.05	1/2	1/2	31,2	14	9,1	16 1)	350
8	5/16	● BA.21.05.06	1/2	9/16	33	14	9,9	17	350
10	3/8	● BA.21.06.04	9/16	7/16	32,2	14,1	9,1	16 1)	350
10	3/8	● BA.21.06.05	9/16	1/2	32,2	14,1	9,1	16 1)	350
10	3/8	● BA.21.06.06	9/16	9/16	33	14,1	9,9	17	350
10	3/8	● BA.21.06.08	9/16	3/4	35,1	14,1	11,1	22	350
10	3/8	● BA.21.06.10	9/16	7/8	35	14,1	12,7	27	350
12	1/2	● BA.21.08.06	3/4	9/16	36,6	16,7	9,9	19	350
12	1/2	● BA.21.08.08	3/4	3/4	37,6	16,7	11,1	22	350
12	1/2	● BA.21.08.10	3/4	7/8	40,6	16,7	12,7	27	350
12	1/2	● BA.21.08.12	3/4	1" 1/16	44,7	16,7	15,1	32	350
14	-	● BA.21.10.08	7/8	3/4	40,6	19,3	11,1	24	350
15	-	● BA.21.10.08	7/8	3/4	40,6	19,3	11,1	24	350
16	5/8	● BA.21.10.08	7/8	3/4	40,6	19,3	11,1	24	350
14	-	● BA.21.10.10	7/8	7/8	43,2	19,3	12,7	27	350
15	-	● BA.21.10.10	7/8	7/8	43,2	19,3	12,7	27	350
16	5/8	● BA.21.10.10	7/8	7/8	43,2	19,3	12,7	27	350
14	-	● BA.21.10.12	7/8	1" 1/16	47,2	19,3	15,1	32	350
15	-	● BA.21.10.12	7/8	1" 1/16	47,2	19,3	15,1	32	350
16	5/8	● BA.21.10.12	7/8	1" 1/16	47,2	19,3	15,1	32	350
18	-	● BA.21.12.08	1" 1/16	3/4	45,2	21,9	11,1	27	350
20	3/4	● BA.21.12.08	1" 1/16	3/4	45,2	21,9	11,1	27	350
18	-	● BA.21.12.10	1" 1/16	7/8	46,4	21,9	12,7	27	350
20	3/4	● BA.21.12.10	1" 1/16	7/8	46,4	21,9	12,7	27	350
18	-	● BA.21.12.12	1" 1/16	1" 1/16	50	21,9	15,1	32	350
20	3/4	● BA.21.12.12	1" 1/16	1" 1/16	50	21,9	15,1	32	350
18	-	● BA.21.12.16	1" 1/16	1" 5/16	50,8	21,9	15,1	38 2)	350
20	3/4	● BA.21.12.16	1" 1/16	1" 5/16	50,8	21,9	15,1	38 2)	350
25	1"	● BA.21.16.10	1" 5/16	7/8	52,8	23,1	12,7	38 2)	280
25	1"	● BA.21.16.12	1" 5/16	1" 1/16	51,1	23,1	15,1	36	280
25	1"	● BA.21.16.16	1" 5/16	1" 5/16	51,8	23,1	15,1	38 2)	280
25	1"	● BA.21.16.20	1" 5/16	1" 5/8	53,8	23,1	15,1	50	280
30	-	● BA.21.20.16	1" 5/8	1" 5/16	55,1	24,3	15,1	50	210
32	1" 1/4	● BA.21.20.16	1" 5/8	1" 5/16	55,1	24,3	15,1	50	210
30	-	● BA.21.20.20	1" 5/8	1" 5/8	55,1	24,3	15,1	50	210
32	1" 1/4	● BA.21.20.20	1" 5/8	1" 5/8	55,1	24,3	15,1	50	210
30	-	● BA.21.20.24	1" 5/8	1" 7/8	56	24,3	15,1	55	140
32	1" 1/4	● BA.21.20.24	1" 5/8	1" 7/8	56	24,3	15,1	55	140
38	1" 1/2	● BA.21.24.20	1" 7/8	1" 5/8	55,5	27,5	15,1	55	140
38	1" 1/2	● BA.21.24.24	1" 7/8	1" 7/8	60,2	27,5	15,1	55	140

1) AISI 316L CH = 17 2) AISI 316L CH = 41



CORPO: TERMINALE DIRITTO MASCHIO METRICO
CILINDRICO - ISO 6149-3

CORPS: TERMINAL DROIT MALE CYLINDRIQUE
METRIQUE - ISO 6149-3

BODY: MALE STUD METRIC PARALLEL -
ISO 6149-3

KÖRPER: GERADE EINSCHRAUB METRISCH
ZYLINDRISCH - ISO 6149-3

CUERPO: ADAPTADOR RECTO MACHO METRICO
CILINDRICO - ISO 6149-3

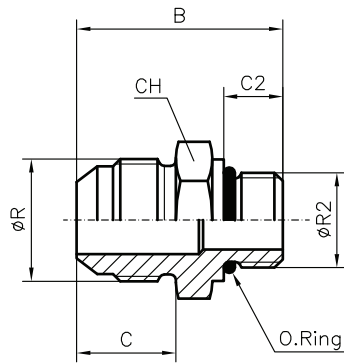

Ø TUBO-TUBE-ROHR		CODICE REFERENCE CODE BEST.-NR. REFERENCIA	Ø R-UNF JIC 37°	Ø R2 Metrico Metrique Metric Metrisch	B	C	C2	CH	PN
mm.	Poll. - Pouces Inch. - Zoll Pulgadas								
6	1/4	● BA.23.04.02	7/16	10x1	31	14	8,5	16 1)	350
6	1/4	● BA.23.04.03	7/16	12x1,5	33	14	11	16	350
8	5/16	● BA.23.05.02	1/2	10x1	30,5	14	8,5	16	350
8	5/16	● BA.23.05.03	1/2	12x1,5	33,5	14	11	19	350
8	5/16	● BA.23.05.04	1/2	14x1,5	33,5	14	11	19	350
10	3/8	● BA.23.06.04	9/16	14x1,5	33,5	14,1	11	19	350
10	3/8	● BA.23.06.05	9/16	16x1,5	35	14,1	11,5	22	350
12	1/2	● BA.23.08.04	3/4	14x1,5	36	16,7	11	19	350
12	1/2	● BA.23.08.05	3/4	16x1,5	37,5	16,7	11,5	22	350
12	1/2	● BA.23.08.06	3/4	18x1,5	39	16,7	12,5	24	350
12	1/2	● BA.23.08.08	3/4	22x1,5	39	16,7	13	27	350
14	-	● BA.23.10.04	7/8	14x1,5	40	19,3	11	24	350
15	-	● BA.23.10.04	7/8	14x1,5	40	19,3	11	24	350
16	5/8	● BA.23.10.04	7/8	14x1,5	40	19,3	11	24	350
14	-	● BA.23.10.06	7/8	18x1,5	42	19,3	12,5	24	350
15	-	● BA.23.10.06	7/8	18x1,5	42	19,3	12,5	24	350
16	5/8	● BA.23.10.06	7/8	18x1,5	42	19,3	12,5	24	350
14	-	● BA.23.10.07	7/8	20x1,5	43	19,3	12,5	27	350
15	-	● BA.23.10.07	7/8	20x1,5	43	19,3	12,5	27	350
16	5/8	● BA.23.10.07	7/8	20x1,5	43	19,3	12,5	27	350
14	-	● BA.23.10.08	7/8	22x1,5	43	19,3	13	27	350
15	-	● BA.23.10.08	7/8	22x1,5	43	19,3	13	27	350
16	5/8	● BA.23.10.08	7/8	22x1,5	43	19,3	13	27	350
18	-	● BA.23.12.06	1" 1/16	18x1,5	44	21,9	12,5	27	350
20	3/4	● BA.23.12.06	1" 1/16	18x1,5	44	21,9	12,5	27	350
18	-	● BA.23.12.08	1" 1/16	22x1,5	45,5	21,9	13	27	350
20	3/4	● BA.23.12.08	1" 1/16	22x1,5	45,5	21,9	13	27	350
18	-	● BA.23.12.14	1" 1/16	27x2	49	21,9	16	32	350
20	3/4	● BA.23.12.14	1" 1/16	27x2	49	21,9	16	32	350
25	1"	● BA.23.16.14	1" 5/16	27x2	50,5	23,1	16	36	280
25	1"	● BA.23.16.16	1" 5/16	33x2	51,5	23,1	16	41	280
30	-	● BA.23.20.20	1" 5/8	42x2	55	24,3	16	50	210
32	1" 1/4	● BA.23.20.20	1" 5/8	42x2	55	24,3	16	50	210
38	1" 1/2	● BA.23.24.24	1" 7/8	48x2	59,5	27,5	17,5	55	140

1) AISI 316L CH = 17



CORPO: TERMINALE DIRITTO MASCHIO METRICO
CILINDRICO - RONDELLA TENUTA O-RING

CORPS: TERMINAL DROIT MALE CYLINDRIQUE
METRIQUE - RONDELLE D'ETANCHEITE
O-RING

BODY: MALE STUD METRIC PARALLEL -
O-RING SEALRING

KÖRPER: GERADE EINSCHRAUB METRISCH
ZYLINDRISCH - BEWEGLICHE
UNTERLEGSCHLEIBE F.O-RING

CUERPO: ADAPTADOR RECTO MACHO METRICO
CILINDRICO - ARANDELA DE RETENCION
JUNTA TORICA

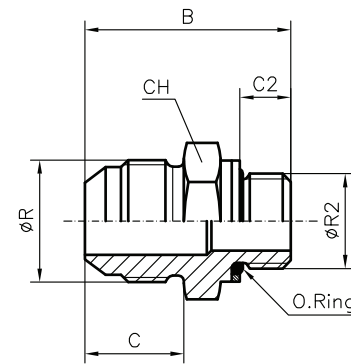

Ø TUBO-TUBE-ROHR		CODICE REFERENCE CODE BEST.-NR. REFERENCIA	Ø R-UNF JIC 37°	Ø R2 Metrico Metric Metric	B	C	C2	CH	PN
mm.	Poll. - Pouces Inch. - Zoll Pulgadas								
6	1/4	● BA.23.04.02 W	7/16	10x1	31	14	7,5	16 1)	350
6	1/4	● BA.23.04.03 W	7/16	12x1,5	33	14	9,5	16 1)	350
8	5/16	● BA.23.05.02 W	1/2	10x1	31,5	14	7,5	16 1)	350
8	5/16	● BA.23.05.03 W	1/2	12x1,5	33,5	14	9,5	19	350
8	5/16	● BA.23.05.04 W	1/2	14x1,5	33,5	14	9,5	19	350
10	3/8	● BA.23.06.04 W	9/16	14x1,5	33,5	14,1	9,5	19	350
10	3/8	● BA.23.06.05 W	9/16	16x1,5	35	14,1	10	22	350
12	1/2	● BA.23.08.04 W	3/4	14x1,5	36	16,7	9,5	19	350
12	1/2	● BA.23.08.05 W	3/4	16x1,5	37,5	16,7	10	22	350
12	1/2	● BA.23.08.06 W	3/4	18x1,5	39	16,7	11	24	350
12	1/2	● BA.23.08.08 W	3/4	22x1,5	39	16,7	11,5	27	350
14	-	● BA.23.10.04 W	7/8	14x1,5	40	19,3	9,5	24	350
15	-	● BA.23.10.04 W	7/8	14x1,5	40	19,3	9,5	24	350
16	5/8	● BA.23.10.04 W	7/8	14x1,5	40	19,3	9,5	24	350
14	-	● BA.23.10.06 W	7/8	18x1,5	42	19,3	11	24	350
15	-	● BA.23.10.06 W	7/8	18x1,5	42	19,3	11	24	350
16	5/8	● BA.23.10.06 W	7/8	18x1,5	42	19,3	11	24	350
14	-	● BA.23.10.07 W	7/8	20x1,5	43	19,3	11,5	27	350
15	-	● BA.23.10.07 W	7/8	20x1,5	43	19,3	11,5	27	350
16	5/8	● BA.23.10.07 W	7/8	20x1,5	43	19,3	11,5	27	350
14	-	● BA.23.10.08 W	7/8	22x1,5	43	19,3	11,5	27	350
15	-	● BA.23.10.08 W	7/8	22x1,5	43	19,3	11,5	27	350
16	5/8	● BA.23.10.08 W	7/8	22x1,5	43	19,3	11,5	27	350
18	-	● BA.23.12.06 W	1" 1/16	18x1,5	44	21,9	11	27	350
20	3/4	● BA.23.12.06 W	1" 1/16	18x1,5	44	21,9	11	27	350
18	-	● BA.23.12.08 W	1" 1/16	22x1,5	45,5	21,9	11,5	27	350
20	3/4	● BA.23.12.08 W	1" 1/16	22x1,5	45,5	21,9	11,5	27	350
18	-	● BA.23.12.14 W	1" 1/16	27x2	49	21,9	14	32	350
20	3/4	● BA.23.12.14 W	1" 1/16	27x2	49	21,9	14	32	350
25	1"	● BA.23.16.14 W	1" 5/16	27x2	50,5	23,1	14	36	250
25	1"	● BA.23.16.16 W	1" 5/16	33x2	51,5	23,1	14	41	250
30	-	● BA.23.20.20 W	1" 5/8	42x2	55	24,3	14	50	210
32	1" 1/4	● BA.23.20.20 W	1" 5/8	42x2	55	24,3	14	50	210
38	1" 1/2	● BA.23.24.24 W	1" 7/8	48x2	59,5	27,5	15,5	55	140

1) AISI 316L CH = 17



CORPO: TERMINALE DIRITTO MASCHIO METRICO CILINDRICO
GG - GUARNIZIONE GOMMA - FORMA E DIN 3852

CORPS: TERMINAL DROIT MALE CYLINDRIQUE METRIQUE
GG - JOINT EN CAOUTCHOUC - FORME E DIN 3852

BODY: MALE STUD METRIC PARALLEL GG - RUBBER
SEAL - TYPE E DIN 3852

KÖRPER: GERADE EINSCHRAUB METRISCH ZYLINDRISCH
GG - GUMMIDICHTUNG - FORM E DIN 3852

CUERPO: ADAPTADOR RECTO MACHO METRICO CILINDRICO
GG - JUNTA DE GOMA - FORMA E DIN 3852

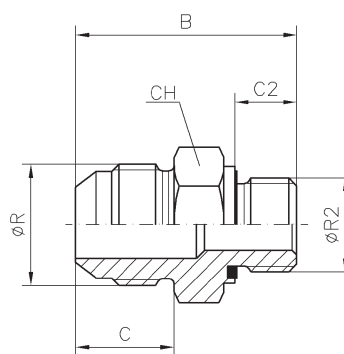

Ø TUBO-TUBE-ROHR		CODICE REFERENCE CODE BEST.-NR. REFERENCIA	Ø R-UNF JIC 37°	Ø R2 Metrico Metrique Metric Metrisch	B	C	C2	CH	PN
mm.	Poll. - Pouces Inch. - Zoll Pulgadas								
6	1/4	● BA.24.04.02	7/16	10x1	30,5	14	8	14	350
6	1/4	● BA.24.04.03	7/16	12x1,5	35,5	14	12	17	350
8	5/16	● BA.24.05.02	1/2	10x1	31,5	14,1	8	14	350
8	5/16	● BA.24.05.03	1/2	12x1,5	35,5	14,1	12	17	350
8	5/16	● BA.24.05.04	1/2	14x1,5	35,5	14,1	12	19	350
10	3/8	● BA.24.06.04	9/16	14x1,5	35,5	14,1	12	19	350
10	3/8	● BA.24.06.05	9/16	16x1,5	37	14,1	12	22	350
12	1/2	● BA.24.08.04	3/4	14x1,5	38,5	16,7	12	19	350
12	1/2	● BA.24.08.05	3/4	16x1,5	39,5	16,7	12	22	350
12	1/2	● BA.24.08.06	3/4	18x1,5	40	16,7	12	24	350
14	-	● BA.24.10.06	7/8	18x1,5	42,5	19,3	12	24	350
15	-	● BA.24.10.06	7/8	18x1,5	42,5	19,3	12	24	350
16	5/8	● BA.24.10.06	7/8	18x1,5	42,5	19,3	12	24	350
14	-	● BA.24.10.07	7/8	20x1,5	43	19,3	11,5	27	350
15	-	● BA.24.10.07	7/8	20x1,5	43	19,3	11,5	27	350
16	5/8	● BA.24.10.07	7/8	20x1,5	43	19,3	11,5	27	350
14	-	● BA.24.10.08	7/8	22x1,5	45	19,3	14	27	350
15	-	● BA.24.10.08	7/8	22x1,5	45	19,3	14	27	350
16	5/8	● BA.24.10.08	7/8	22x1,5	45	19,3	14	27	350
18	-	● BA.24.12.08	1" 1/16	22x1,5	48	21,9	14	27	350
20	3/4	● BA.24.12.08	1" 1/16	22x1,5	48	21,9	14	27	350
18	-	● BA.24.12.14	1" 1/16	27x2	51	21,9	16	32	350
20	3/4	● BA.24.12.14	1" 1/16	27x2	51	21,9	16	32	350
25	1"	● BA.24.16.14	1" 5/16	27x2	53,5	23,1	16	36	280
25	1"	● BA.24.16.16	1" 5/16	33x2	55,5	23,1	18	41	280
30	-	● BA.24.20.20	1" 5/8	42x2	61	24,3	20	50	210
32	1" 1/4	● BA.24.20.20	1" 5/8	42x2	61	24,3	20	50	210
38	1" 1/2	● BA.24.24.24	1" 7/8	48x2	66	27,5	22	55	140



CORPO: TERMINALE DIRITTO MASCHIO NPT
CORPS: TERMINAL DROIT MALE NPT
BODY: MALE STUD NPT
KÖRPER: GERADE EINSCHRAUB NPT
CUERPO: ADAPTADOR RECTO MACHO NPT

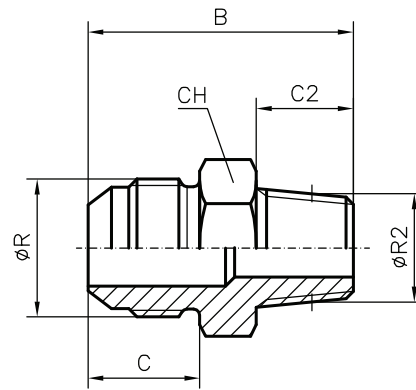

Ø TUBO-TUBE-ROHR		CODICE REFERENCE CODE BEST.-NR. REFERENCIA	Ø R-UNF JIC 37°	Ø R2 NPT	B	C	C2	CH	PN
mm.	Poll. - Pouces Inch. - Zoll Pulgadas								
6	1/4	● BA.25.04.02	7/16	1/8	31	14	9,7	13 ¹⁾	350
6	1/4	● BA.25.04.04	7/16	1/4	36	14	14,2	14	350
6	1/4	● BA.25.04.06	7/16	3/8	37	14	14,2	19	350
6	1/4	● BA.25.04.08	7/16	1/2	42,5	14	19	22	350
8	5/16	● BA.25.05.02	1/2	1/8	31	14	9,7	14	350
8	5/16	● BA.25.05.04	1/2	1/4	36,1	14	14,2	14	350
10	3/8	● BA.25.06.02	9/16	1/8	31,8	14,1	9,7	16 ²⁾	350
10	3/8	● BA.25.06.04	9/16	1/4	36,3	14,1	14,2	16 ²⁾	350
10	3/8	● BA.25.06.06	9/16	3/8	36,3	14,1	14,2	19	350
10	3/8	● BA.25.06.08	9/16	1/2	42,5	14,1	19	22	350
12	1/2	● BA.25.08.04	3/4	1/4	38,9	16,7	14,2	19	350
12	1/2	● BA.25.08.06	3/4	3/8	38,9	16,7	14,2	19	350
12	1/2	● BA.25.08.08	3/4	1/2	45,4	16,7	19	22	350
12	1/2	● BA.25.08.12	3/4	3/4	47	16,7	19	27	350
14	-	● BA.25.10.06	7/8	3/8	43,1	19,3	14,2	24	350
15	-	● BA.25.10.06	7/8	3/8	43,1	19,3	14,2	24	350
16	5/8	● BA.25.10.06	7/8	3/8	43,1	19,3	14,2	24	350
14	-	● BA.25.10.08	7/8	1/2	48	19,3	19	24	350
15	-	● BA.25.10.08	7/8	1/2	48	19,3	19	24	350
16	5/8	● BA.25.10.08	7/8	1/2	48	19,3	19	24	350
14	-	● BA.25.10.12	7/8	3/4	49,5	19,3	19	27	350
15	-	● BA.25.10.12	7/8	3/4	49,5	19,3	19	27	350
16	5/8	● BA.25.10.12	7/8	3/4	49,5	19,3	19	27	350
18	-	● BA.25.12.08	1" 1/16	1/2	52,1	21,9	19	27	350
20	3/4	● BA.25.12.08	1" 1/16	1/2	52,1	21,9	19	27	350
18	-	● BA.25.12.12	1" 1/16	3/4	52,3	21,9	19	27	350
20	3/4	● BA.25.12.12	1" 1/16	3/4	52,3	21,9	19	27	350
18	-	● BA.25.12.16	1" 1/16	1"	57,1	21,9	23,9	36	280
20	3/4	● BA.25.12.16	1" 1/16	1"	57,1	21,9	23,9	36	280
25	1"	● BA.25.16.08	1" 5/16	1/2	53,5	23,1	19	36	280
25	1"	● BA.25.16.12	1" 5/16	3/4	53,5	23,1	19	36	280
25	1"	● BA.25.16.16	1" 5/16	1"	58,4	23,1	23,9	36	280
30	-	● BA.25.20.16	1" 5/8	1"	61,5	24,3	23,9	46	210
32	1" 1/4	● BA.25.20.16	1" 5/8	1"	61,5	24,3	23,9	46	210
30	-	● BA.25.20.20	1" 5/8	1" 1/4	62,2	24,3	24,6	46	210
32	1" 1/4	● BA.25.20.20	1" 5/8	1" 1/4	62,2	24,3	24,6	46	210
38	1" 1/2	● BA.25.24.20	1" 7/8	1" 1/4	68,1	27,5	24,6	50	140
38	1" 1/2	● BA.25.24.24	1" 7/8	1" 1/2	68,1	27,5	25,4	50	140

1) AISI 316L CH = 14 2) AISI 316L CH = 17



CORPO: TERMINALE DIRITTO MASCHIO BSPT
(GAS CONICO)

CORPS: TERMINAL DROIT MALE BSPT
(GAZ CONIQUE)

BODY: MALE STUD BSPT
(BSP TAPERED)

KÖRPER: GERADEEINSCHRAUBVERSCHRAUBUNG
(WHITWORTH-ROHRGEWINDE KEGELIG)

CUERPO: ADAPTADOR RECTO MACHO BSPT
(GAS CONICO)

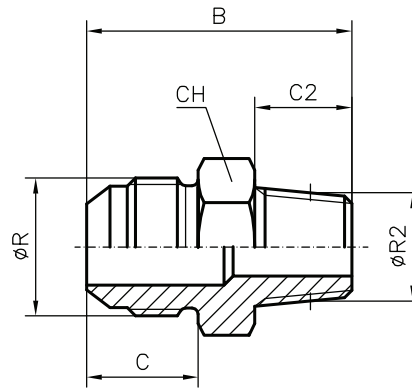

Ø TUBO-TUBE-ROHR		CODICE REFERENCE CODE BEST.-NR. REFERENCIA	Ø R-UNF JIC 37°	Ø R2 BSPT	B	C	C2	CH	PN
mm.	Poll. - Pouces Inch. - Zoll Pulgadas								
6	1/4	● BA.26.04.02	7/16	1/8	30,7	14	9,7	13 1)	350
6	1/4	● BA.26.04.04	7/16	1/4	35,3	14	14,2	14	350
8	5/16	● BA.26.05.02	1/2	1/8	30,7	14	9,7	14	350
8	5/16	● BA.26.05.04	1/2	1/4	35,3	14	14,2	14	350
10	3/8	● BA.26.06.02	9/16	1/8	31,1	14,1	9,7	16 2)	350
10	3/8	● BA.26.06.04	9/16	1/4	35,6	14,1	14,2	16 2)	350
10	3/8	● BA.26.06.06	9/16	3/8	35,6	14,1	14,2	19	350
10	3/8	● BA.26.06.08	9/16	1/2	41,1	14,1	19	22	350
12	1/2	● BA.26.08.04	3/4	1/4	38,1	16,7	14,2	19	350
12	1/2	● BA.26.08.06	3/4	3/8	38,1	16,7	14,2	19	350
12	1/2	● BA.26.08.08	3/4	1/2	43,7	16,7	19	22	350
12	1/2	● BA.26.08.12	3/4	3/4	45,7	16,7	19	27	350
14	-	● BA.26.10.06	7/8	3/8	41,9	19,3	14,2	24	350
15	-	● BA.26.10.06	7/8	3/8	41,9	19,3	14,2	24	350
16	5/8	● BA.26.10.06	7/8	3/8	41,9	19,3	14,2	24	350
14	-	● BA.26.10.08	7/8	1/2	46,7	19,3	19	24	350
15	-	● BA.26.10.08	7/8	1/2	46,7	19,3	19	24	350
16	5/8	● BA.26.10.08	7/8	1/2	46,7	19,3	19	24	350
14	-	● BA.26.10.12	7/8	3/4	48,3	19,3	19	27	350
15	-	● BA.26.10.12	7/8	3/4	48,3	19,3	19	27	350
16	5/8	● BA.26.10.12	7/8	3/4	48,3	19,3	19	27	350
18	-	● BA.26.12.08	1" 1/16	1/2	50,8	21,9	19	27	350
20	3/4	● BA.26.12.08	1" 1/16	1/2	50,8	21,9	19	27	350
18	-	● BA.26.12.12	1" 1/16	3/4	50,8	21,9	19	27	350
20	3/4	● BA.26.12.12	1" 1/16	3/4	50,8	21,9	19	27	350
18	-	● BA.26.12.16	1" 1/16	1"	56,6	21,9	23,9	36	280
20	3/4	● BA.26.12.16	1" 1/16	1"	56,6	21,9	23,9	36	280
25	1"	● BA.26.16.08	1" 5/16	1/2	53,1	23,1	19	36	280
25	1"	● BA.26.16.12	1" 5/16	3/4	53,1	23,1	19	36	280
25	1"	● BA.26.16.16	1" 5/16	1"	57,9	23,1	23,9	36	280
30	-	● BA.26.20.16	1" 5/8	1"	60,2	24,3	23,9	46	210
32	1" 1/4	● BA.26.20.16	1" 5/8	1"	60,2	24,3	23,9	46	210
30	-	● BA.26.20.20	1" 5/8	1" 1/4	61	24,3	24,6	46	210
32	1" 1/4	● BA.26.20.20	1" 5/8	1" 1/4	61	24,3	24,6	46	210
38	1" 1/2	● BA.26.24.20	1" 7/8	1" 1/4	65,5	27,5	24,6	50	140
38	1" 1/2	● BA.26.24.24	1" 7/8	1" 1/2	66,3	27,5	25,4	50	140

1) AISI 316L CH = 14 2) AISI 316L CH = 17



CORPO: TERMINALE DIRITTO FEMMINA NPT
CORPS: TERMINAL DROIT MALE FEMELLE NPT
BODY: FEMALE STUD NPT
KÖRPER: GERADE AUFSCHRAUB NPT
CUERPO: ADAPTADOR RECTO HEMBRA NPT

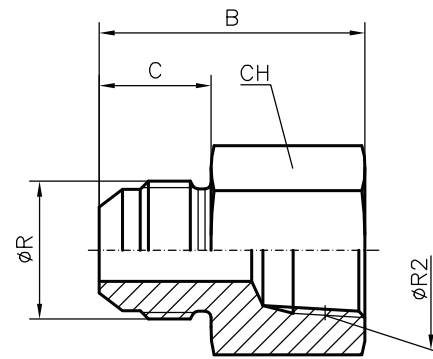

Ø TUBO-TUBE-ROHR		CODICE REFERENCE CODE BEST.-NR. REFERENCIA	Ø R-UNF JIC 37°	Ø R2 NPT	B	C	CH	PN
mm.	Poll. - Pouces Inch. - Zoll Pulgadas							
6	1/4	● BA.28.04.02	7/16	1/8	30,2	14	14	350
6	1/4	● BA.28.04.04	7/16	1/4	35,3	14	19	350
8	5/16	● BA.28.05.02	1/2	1/8	29,7	14	14	350
8	5/16	● BA.28.05.04	1/2	1/4	35,3	14	19	350
10	3/8	● BA.28.06.04	9/16	1/4	35,6	14,1	19	350
10	3/8	● BA.28.06.06	9/16	3/8	37,1	14,1	22	350
12	1/2	● BA.28.08.04	3/4	1/4	39,6	16,7	22	350
12	1/2	● BA.28.08.06	3/4	3/8	39,6	16,7	22	350
12	1/2	● BA.28.08.08	3/4	1/2	45,6	16,7	30	350
14	-	● BA.28.10.08	7/8	1/2	48	19,3	30	350
15	-	● BA.28.10.08	7/8	1/2	48	19,3	30	350
16	5/8	● BA.28.10.08	7/8	1/2	48	19,3	30	350
18	-	● BA.28.12.08	1" 1/16	1/2	52,1	21,9	30	350
20	3/4	● BA.28.12.08	1" 1/16	1/2	52,1	21,9	30	350
18	-	● BA.28.12.12	1" 1/16	3/4	52,3	21,9	36	350
20	3/4	● BA.28.12.12	1" 1/16	3/4	52,3	21,9	36	350
25	1"	● BA.28.16.16	1" 5/16	1"	59,7	23,1	41	250
30	-	● BA.28.20.20	1" 5/8	1" 1/4	63,2	24,3	50	210
32	1" 1/4	● BA.28.20.20	1" 5/8	1" 1/4	63,2	24,3	50	210
38	1" 1/2	● BA.28.24.24	1" 7/8	1" 1/2	66,5	27,5	60	140



CORPO: TERMINALE DIRITTO FEMMINA BSPP
(GAS CILINDRICO)
CORPS: TERMINAL DROIT MALE FEMELLE BSPP
(GAZ CYLINDRIQUE)
BODY: FEMALE STUD BSPP
(B.S.P. TAPERED)
KÖRPER: GERADE AUFSCHRAUB BSPP
(B.S.P. ZYLINDRISCH)
CUERPO: ADAPTADOR RECTO HEMBRA BSPP
(GAS CILINDRICO)

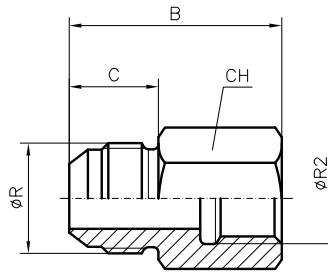

Ø TUBO-TUBE-ROHR		CODICE REFERENCE CODE BEST.-NR. REFERENCIA	Ø R-UNF JIC 37°	Ø R2 BSPP	B	C	CH	PN
mm.	Poll. - Pouces Inch. - Zoll Pulgadas							
6	1/4	● BA.29.04.02	7/16	1/8	30,2	14	14	350
6	1/4	● BA.29.04.04	7/16	1/4	35,3	14	19	350
8	5/16	● BA.29.05.02	1/2	1/8	29,7	14	14	350
8	5/16	● BA.29.05.04	1/2	1/4	35,3	14	19	350
10	3/8	● BA.29.06.04	9/16	1/4	35,6	14,1	19	350
10	3/8	● BA.29.06.06	9/16	3/8	37,1	14,1	22	350
10	3/8	● BA.29.06.08	9/16	1/2	43	14,1	30	350
12	1/2	● BA.29.08.04	3/4	1/4	39,6	16,7	22	350
12	1/2	● BA.29.08.06	3/4	3/8	39,6	16,7	22	350
12	1/2	● BA.29.08.08	3/4	1/2	45,6	16,7	30	350
14	-	● BA.29.10.08	7/8	1/2	48	19,3	30	350
15	-	● BA.29.10.08	7/8	1/2	48	19,3	30	350
16	5/8	● BA.29.10.08	7/8	1/2	48	19,3	30	350
18	-	● BA.29.12.08	1" 1/16	1/2	52,1	21,9	30	350
20	3/4	● BA.29.12.08	1" 1/16	1/2	52,1	21,9	30	350
18	-	● BA.29.12.12	1" 1/16	3/4	52,3	21,9	36	350
20	3/4	● BA.29.12.12	1" 1/16	3/4	52,3	21,9	36	350
25	1"	● BA.29.16.16	1" 5/16	1"	59,7	23,1	46	280
30	-	● BA.29.20.16	1" 5/8	1"	63,2	24,3	50	210
32	1" 1/4	● BA.29.20.16	1" 5/8	1"	63,2	24,3	50	210
30	-	● BA.29.20.20	1" 5/8	1" 1/4	63,2	24,3	50	210
32	1" 1/4	● BA.29.20.20	1" 5/8	1" 1/4	63,2	24,3	50	210
38	1" 1/2	● BA.29.24.20	1" 7/8	1" 1/4	66,5	27,5	60	140
38	1" 1/2	● BA.29.24.24	1" 7/8	1" 1/2	66,5	27,5	60	140

CORPO: TERMINALE DIRITTO FEMMINA BSPP
(GAS CILINDRICO)
RACCORDO PER MANOMETRO
CORPS: TERMINAL DROIT FEMELLE BSPP
(GAZ CYLINDRIQUE)
UNION POUR MANOMETRE
BODY: FEMALE STUD BSPP
(B.S.P. PARALLEL)
GAUGE COUPLINGS
KÖRPER: GERADE AUFSCHRAUB BSPP
(B.S.P. ZYLINDRISCH)
MANOMETER-VERSCHRAUBUNGEN
CUERPO: ADAPTADOR RECTO HEMBRA BSPP
(GAS CILINDRICO)
RACOR PARA MANÓMETRO

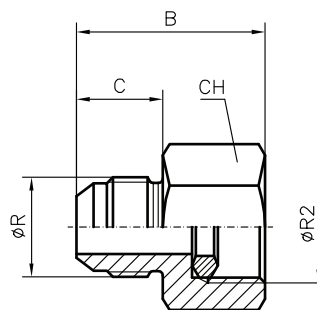

Ø TUBO-TUBE-ROHR		CODICE REFERENCE CODE BEST.-NR. REFERENCIA	Ø R-UNF JIC 37°	Ø R2 BSPP	B	C	CH	PN
mm.	Poll. - Pouces Inch. - Zoll Pulgadas							
6	1/4	● BA.30.04.04	7/16	1/4	33	14	19	350
6	1/4	● BA.30.04.08	7/16	1/2	40	14	27	350
8	5/16	● BA.30.05.04	1/2	1/4	33	14	19	350
8	5/16	● BA.30.05.08	1/2	1/2	40	14	27	350
10	3/8	● BA.30.06.04	9/16	1/4	33,1	14,1	19	350
10	3/8	● BA.30.06.08	9/16	1/2	40,1	14,1	27	350
12	1/2	● BA.30.08.04	3/4	1/4	35,7	16,7	19	350
12	1/2	● BA.30.08.08	3/4	1/2	42,7	16,7	27	350



CORPO: RIDUZIONE
CORPS: REDUCTION
BODY: STUD ADAPTOR
KÖRPER: REDUZIERVERSCHRAUBUNG
CUERPO: REDUCCIÓN

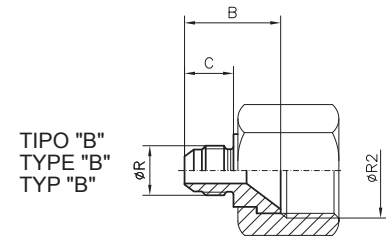
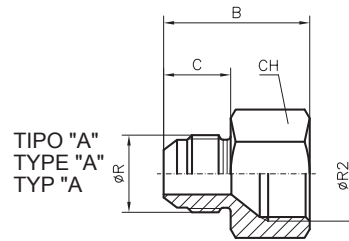

Ø TUBO-TUBE-ROHR				CODICE REFERENCE CODE BEST.-NR. REFERENCIA	Ø R2-UNF JIC37°	Ø R-UNF JIC 37°	B	CH	Tipo Type Typ	C	PN
mm.	mm.	Poll. Pouces Inch. - Zoll Pulgadas	Poll. Pouces Inch. - Zoll Pulgadas								
8	6	5/16	1/4	● BA.31.05.04	1/2	7/16	28	19	A	14	350
10	6	3/8	1/4	● BA.31.06.04	9/16	7/16	24,6	-	B	14	350
10	8	3/8	5/16	● BA.31.06.05	9/16	1/2	29	19	A	14	350
12	6	1/2	1/4	● BA.31.08.04	3/4	7/16	25,4	-	B	14	350
12	8	1/2	5/16	● BA.31.08.05	3/4	1/2	25,4	-	B	14	350
12	10	1/2	3/8	● BA.31.08.06	3/4	9/16	25,4	-	B	14,1	350
14-15-16	6	5/8	1/4	● BA.31.10.04	7/8	7/16	26,2	-	B	14	350
14-15-16	8	5/8	5/16	● BA.31.10.05	7/8	1/2	26,2	-	B	14	350
14-15-16	10	5/8	3/8	● BA.31.10.06	7/8	9/16	26,2	-	B	14,1	350
14-15-16	12	5/8	1/2	● BA.31.10.08	7/8	3/4	36,5	27	A	16,7	350
18-20	6	3/4	1/4	● BA.31.12.04	1" 1/16	7/16	27,6	-	B	14	350
18-20	8	3/4	5/16	● BA.31.12.05	1" 1/16	1/2	27,6	-	B	14	350
18-20	10	3/4	3/8	● BA.31.12.06	1" 1/16	9/16	27,6	-	B	14,1	350
18-20	12	3/4	1/2	● BA.31.12.08	1" 1/16	3/4	30,2	-	B	16,7	350
18-20	14-15-16	3/4	5/8	● BA.31.12.10	1" 1/16	7/8	42,1	32	A	19,3	350
25	6	1"	1/4	● BA.31.16.04	1" 5/16	7/16	29,4	-	B	14	280
25	8	1"	5/16	● BA.31.16.05	1" 5/16	1/2	29,4	-	B	14	280
25	10	1"	3/8	● BA.31.16.06	1" 5/16	9/16	29,4	-	B	14,1	280
25	12	1"	1/2	● BA.31.16.08	1" 5/16	3/4	32,1	-	B	16,7	280
25	14-15-16	1"	5/8	● BA.31.16.10	1" 5/16	7/8	34,7	-	B	19,3	280
25	18-20	1"	3/4	● BA.31.16.12	1" 5/16	1" 1/16	37,3	-	B	21,9	280
30-32	6	1" 1/4	1/4	● BA.31.20.04	1" 5/8	7/16	31,2	-	B	14	210
30-32	8	1" 1/4	5/16	● BA.31.20.05	1" 5/8	1/2	31,2	-	B	14	210
30-32	10	1" 1/4	3/8	● BA.31.20.06	1" 5/8	9/16	31,2	-	B	14,1	210
30-32	12	1" 1/4	1/2	● BA.31.20.08	1" 5/8	3/4	33,9	-	B	16,7	210
30-32	14-15-16	1" 1/4	5/8	● BA.31.20.10	1" 5/8	7/8	36,5	-	B	19,3	210
30-32	18-20	1" 1/4	3/4	● BA.31.20.12	1" 5/8	1" 1/16	39,1	-	B	21,9	210
30-32	25	1" 1/4	1"	● BA.31.20.16	1" 5/8	1" 5/16	40,3	-	B	23,1	210
38	6	1" 1/2	1/4	● BA.31.24.04	1" 7/8	7/16	32,6	-	B	14	140
38	8	1" 1/2	5/16	● BA.31.24.05	1" 7/8	1/2	32,6	-	B	14	140
38	10	1" 1/2	3/8	● BA.31.24.06	1" 7/8	9/16	32,6	-	B	14,1	140
38	12	1" 1/2	1/2	● BA.31.24.08	1" 7/8	3/4	35,3	-	B	16,7	140
38	14-15-16	1" 1/2	5/8	● BA.31.24.10	1" 7/8	7/8	37,9	-	B	19,3	140
38	18-20	1" 1/2	3/4	● BA.31.24.12	1" 7/8	1" 1/16	40,5	-	B	21,9	140
38	25	1" 1/2	1"	● BA.31.24.16	1" 7/8	1" 5/16	41,7	-	B	23,1	140
38	30-32	1" 1/2	1" 1/4	● BA.31.24.20	1" 7/8	1" 5/8	42,9	-	B	24,3	140

- 1) Per il raccordo tipo B il dado BA 13 ___ ___ è fornito su richiesta.
- 2) Pour le raccord type B, l'écrou BA 13 ___ ___ est fourni sur demande.
- 3) For the type B fitting, the nut BA 13 ___ ___ is supplied on request.
- 4) Für Rohrverschraubungen Typ B wird die Mutter BA 13 ___ ___ auf Wunsch geliefert.
- 5) Por el racor tipo B la tuerca BA 13 ___ ___ es suministrada a petición.



CORPO: RACCORDO PER PRESA PRESSIONE
CORPS: UNION PRISE DE PRESSION
BODY: PRESSURE GAUGE CONNECTOR
KÖRPER: ADAPTER FÜR PRÜ FANSCHLUß
CUERPO: TOMA DE PRESIÓN

TIPO "A"
TYPE "A"
TYP "A"

TIPO "B"
TYPE "B"
TYP "B"

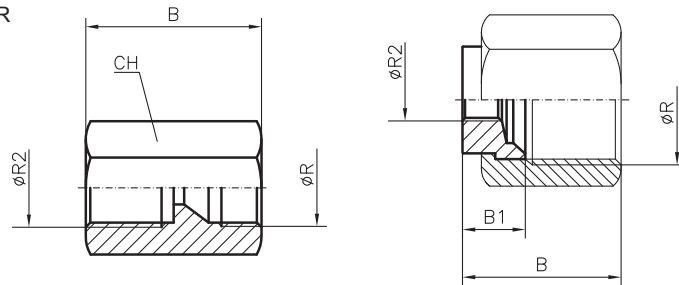

Ø TUBO-TUBE-ROHR		CODICE REFERENCE CODE BEST.-NR. REFERENCIA	Ø R-UNF JIC37°	Ø R2 BSPP	B	B1	CH	Tipo Type Typ	PN
mm.	Poll. - Pouces Inch. - Zoll								
6	1/4	● BA.33.04.04	7/16	1/4	29	-	19	A	350
8	5/16	● BA.33.05.04	1/2	1/4	29	-	19	A	350
10	3/8	● BA.33.06.04	9/16	1/4	29	-	19	A	350
12	1/2	● BA.33.08.04	3/4	1/4	32	-	22	A	350
14-15-16	5/8	● BA.33.10.04	7/8	1/4	32	-	27	A	350
18-20	3/4	● BA.33.12.04	1" 1/16	1/4	25,9	17	32	B	350
25	1"	● BA.33.16.04	1" 5/16	1/4	28,4	17,5	41	B	280
30-32	1" 1/4	● BA.33.20.04	1" 5/8	1/4	31	19	50	B	210
38	1" 1/2	● BA.33.24.04	1" 7/8	1/4	35,8	24	60	B	210

- 1) Per il raccordo tipo B il dado BA 13___ è fornito su richiesta.
- 2) Pour le raccord type B, l'écrou BA 13___ est fourni sur demande.
- 3) For the type B fitting, the nut BA 13___ is supplied on request.
- 4) Für Rohrverschraubungen Typ B wird die Mutter BA 13___ auf Wunsch geliefert.
- 5) Por el racor tipo B la tuerca BA 13___ es suministrada a petición.

CORPO: SALDABILE
CORPS: A SOUDER
BODY: WELDING
KÖRPER: ANSCHWEISSBAR
CUERPO: SOLDABLE

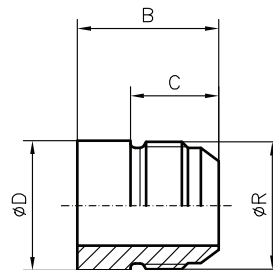

Ø TUBO-TUBE-ROHR		CODICE REFERENCE CODE BEST.-NR. REFERENCIA	Ø R-UNF JIC37°	B	C	Ø D	PN
mm.	Poll. - Pouces Inch. - Zoll						
6	1/4	● BA.39.00.04	7/16	23	14	12	350
8	5/16	● BA.39.00.05	1/2	24	14	13	350
10	3/8	● BA.39.00.06	9/16	24	14,1	15	350
12	1/2	● BA.39.00.08	3/4	27	16,7	20	350
14-15-16	5/8	● BA.39.00.10	7/8	30	19,3	23	350
18-20	3/4	● BA.39.00.12	1" 1/16	34	21,9	28	350
25	1"	● BA.39.00.16	1" 5/16	37	23,1	34	280
30-32	1" 1/4	● BA.39.00.20	1" 5/8	40	24,3	42	210
38	1" 1/2	● BA.39.00.24	1" 7/8	45	27,5	48	210



TAPPO PER RACCORDO
OBTURATEUR POUR RACCORD
PLUG FOR FITTING
VERSCHLUSSBOLZEN
TAPON PARA RACOR

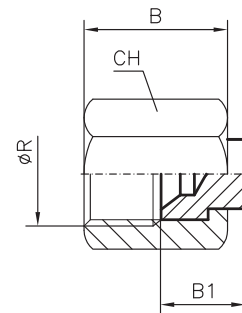

Ø TUBO-TUBE-ROHR		CODICE REFERENCE CODE BEST.-NR. REFERENCIA	Ø R-UNF JIC37°	B	B1	CH	PN	
mm.	Poll. - Pouces Inch. - Zoll Pulgadas							
6	1/4	● BA.43.00.04	7/16	15,5	9	14	350	
8	5/16	● BA.43.00.05	1/2	17	10,5	17	350	
10	3/8	● BA.43.00.06	9/16	18,3	10,5	19	350	
12	1/2	● BA.43.00.08	3/4	21,3	13	22	350	
14-15-16	5/8	● BA.43.00.10	7/8	24,6	14	27	350	
18-20	3/4	● BA.43.00.12	1" 1/16	25,9	14	32	350	
25	1"	● BA.43.00.16	1" 5/16	28,4	17	41	280	
30-32	1" 1/4	● BA.43.00.20	1" 5/8	31	19	50	210	
38	1" 1/2	● BA.43.00.24	1" 7/8	35,8	21	60	240	

TAPPO PER TUBO
OBTURATEUR POUR TUBE
PLUG FOR TUBE
ROHRVESCHLUSS
TAPON PARA TUBO

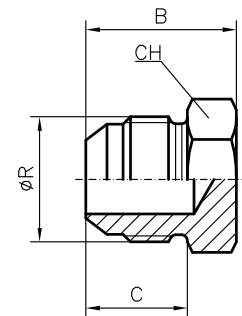

Ø TUBO-TUBE-ROHR		CODICE REFERENCE CODE BEST.-NR. REFERENCIA	Ø R-UNF JIC37°	B	C	CH	PN	
mm.	Poll. - Pouces Inch. - Zoll Pulgadas							
6	1/4	● BA.45.00.04	7/16	20,3	14	13 ¹⁾	350	
8	5/16	● BA.45.00.05	1/2	20,3	14	14	350	
10	3/8	● BA.45.00.06	9/16	21,3	14,1	16 ²⁾	350	
12	1/2	● BA.45.00.08	3/4	23,9	16,7	19	350	
14-15-16	5/8	● BA.45.00.10	7/8	27,9	19,3	24	350	
18-20	3/4	● BA.45.00.12	1" 1/16	32,5	21,9	27	350	
25	1"	● BA.45.00.16	1" 5/16	33,8	23,1	36	280	
30-32	1" 1/4	● BA.45.00.20	1" 5/8	36,8	24,3	46	210	
38	1" 1/2	● BA.45.00.24	1" 7/8	41,9	27,5	50	140	

1) AISI 316L CH = 12 2) AISI 316L CH = 17



CORPO: ADATTATORE MASCHIO NPT
CON DADO GIREVOLE JIC

CORPS: ADAPTATEUR MALE NPT
ECROU PIVOTANT JIC

BODY: MALE STUD ADAPTOR NPT
WITH ROTARY NUT JIC

KÖRPER: EINSCHRAUBADAPTER NPT
MITDREHMUTTER JIC

CUERPO: ADAPTADOR MACHO NPT
CON TUERCA LOCA

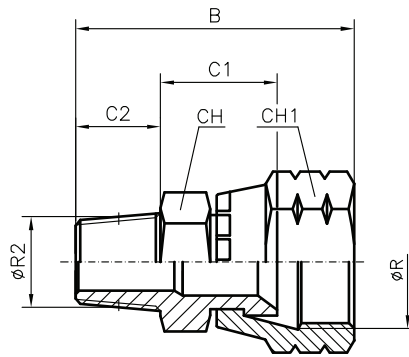

Ø TUBO-TUBE-ROHR		CODICE REFERENCE CODE BEST-NR. REFERENCIA	Ø R-UNF JIC 37°	Ø R2 NPT	B	C1	C2	CH	CH1	PN
mm.	Poll. - Pouces Inch. - Zoll Pulgadas									
6	1/4	● BA.46.04.02	7/16	1/8	34,2	15,8	9,7	13 1)	17	350
6	1/4	● BA.46.04.04	7/16	1/4	39,2	16,3	14,2	14	17	350
8	5/16	● BA.46.05.02	1/2	1/8	37	17,8	9,7	13 2)	19	350
8	5/16	● BA.46.05.04	1/2	1/4	42,1	18,4	14,2	14	19	350
10	3/8	● BA.46.06.02	9/16	1/8	37,6	18,4	9,7	13	19	350
10	3/8	● BA.46.06.04	9/16	1/4	42,1	18,4	14,2	14	19	350
10	3/8	● BA.46.06.06	9/16	3/8	42,2	18,5	14,2	19	19	350
10	3/8	● BA.46.06.08	9/16	1/2	47	18,5	19	22	19	350
12	1/2	● BA.46.08.04	3/4	1/4	45,4	20,5	14,2	19	24	350
12	1/2	● BA.46.08.06	3/4	3/8	45,4	20,5	14,2	19	24	350
12	1/2	● BA.46.08.08	3/4	1/2	51,9	22,2	19	22	24	350
12	1/2	● BA.46.08.12	3/4	3/4	51,9	22,2	19	27	24	350
14-15-16	5/8	● BA.46.10.06	7/8	3/8	48,5	21,6	14,2	22	27	350
14-15-16	5/8	● BA.46.10.08	7/8	1/2	53,5	21,8	19	22	27	350
14-15-16	5/8	● BA.46.10.12	7/8	3/4	53,5	21,8	19	27	27	350
18-20	3/4	● BA.46.12.08	1" 1/16	1/2	58	24,7	19	27	32	350
18-20	3/4	● BA.46.12.12	1" 1/16	3/4	58	24,7	19	27	32	350
25	1"	● BA.46.16.12	1" 5/16	3/4	60	25,9	19	32	38 3)	280
25	1"	● BA.46.16.16	1" 5/16	1"	64,9	25,9	23,9	36	38 3)	280
30-32	1" 1/4	● BA.46.20.16	1" 5/8	1"	68,1	28,3	23,9	41	50	210
30-32	1" 1/4	● BA.46.20.20	1" 5/8	1" 1/4	70,8	30,3	24,6	46	50	210
38	1" 1/2	● BA.46.24.24	1" 7/8	1" 1/2	76,9	32,3	26	50	60	210

1) AISI 316L CH = 12 2) AISI 316L CH = 14 3) AISI 316L CH1 = 41



CORPO: ADATTATORE MASCHIO BSPT (GAS CONICO)
CON DADO GIREVOLE JIC

CORPS: ADAPTATEUR MALE BSPT (GAZ CONIQUE)
ECROU PIVOTANT JIC

BODY: MALE STUD ADAPTOR BSPT (BSP TAPERED)
WITH ROTARY NUT JIC

KÖRPER: EINSCHRAUBADAPTER BSPT
(WHITWORTH-ROHRGEWINDE KEGELIG)
MITDREHMUTTER JIC

CUERPO: ADAPTADOR MACHO BSPT (GAS CONICO)
CON TUERCA LOCA

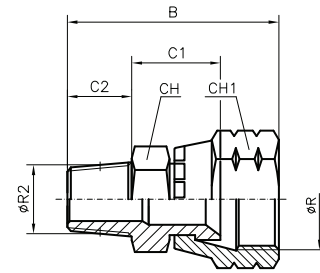

ØTUBO-TUBE-ROHR		CODICE REFERENCE CODE BEST.-NR. REFERENCIA	Ø R-UNF JIC 37°	Ø R2 BSPT	B	C1	C2	CH	CH1	PN
mm.	Poll. - Pouces Inch. - Zoll Pulgadas									
6	1/4	● BA.47.04.02	7/16	1/8	33,9	15,5	9,7	13 1)	17	350
6	1/4	● BA.47.04.04	7/16	1/4	38,5	15,6	14,2	14	17	350
8	5/16	● BA.47.05.02	1/2	1/8	36,8	17,6	9,7	13	19	350
8	5/16	● BA.47.05.04	1/2	1/4	41,3	17,6	14,2	14	19	350
10	3/8	● BA.47.06.04	9/16	1/4	41,5	17,8	14,2	14	19	350
10	3/8	● BA.47.06.06	9/16	3/8	41,5	17,8	14,2	19	19	350
12	1/2	● BA.47.08.04	3/4	1/4	44,6	19,7	14,2	19	24	350
12	1/2	● BA.47.08.06	3/4	3/8	44,6	19,7	14,2	19	24	350
12	1/2	● BA.47.08.08	3/4	1/2	49,4	19,7	19	22	24	350
14-15-16	5/8	● BA.47.10.06	7/8	3/8	47,3	20,4	14,2	22	27	350
14-15-16	5/8	● BA.47.10.08	7/8	1/2	52,1	20,4	19	22	27	350
14-15-16	5/8	● BA.47.10.12	7/8	3/4	54,1	22,4	19	27	27	350
18-20	3/4	● BA.47.12.08	1" 1/16	1/2	56,7	23,4	19	27	32	350
18-20	3/4	● BA.47.12.12	1" 1/16	3/4	56,7	23,4	19	27	32	350
18-20	3/4	● BA.47.12.16	1" 1/16	1"	61,6	23,4	23,9	36	32	350
25	1"	● BA.47.16.12	1" 5/16	3/4	59,6	25,5	19	32	38 2)	280
25	1"	● BA.47.16.16	1" 5/16	1"	64,4	25,4	23,9	36	38 2)	280
30-32	1" 1/4	● BA.47.20.20	1" 5/8	1" 1/4	69,6	29,1	24,6	46	50	210
38	1" 1/2	● BA.47.24.24	1" 7/8	1" 1/2	75,7	31,1	26	50	60	210

1) AISI 316L CH = 12 2) AISI 316L CH1 = 41

CORPO: ADATTATORE MASCHIO UNF-2A
CON DADO GIREVOLE JIC

CORPS: ADAPTATEUR MALE UNF-2A
ECROU PIVOTANT JIC

BODY: MALE STUD ADAPTOR UNF-2A
WITH ROTARY NUT JIC

KÖRPER: EINSCHRAUBADAPTER UNF-2A
MITDREHMUTTER JIC

CUERPO: ADAPTADOR MACHO UNF-2A
CON TUERCA LOCA

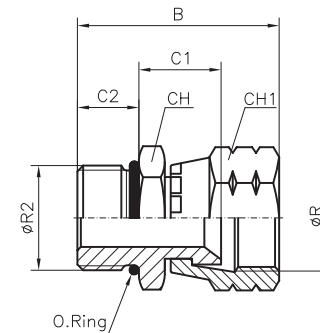

Ø TUBO-TUBE-ROHR		CODICE REFERENCE CODE BEST.-NR. REFERENCIA	Ø R-UNF JIC 37°	Ø R2 UNF	B	C1	C2	CH	CH1	PN
mm.	Poll. - Pouces Inch. - Zoll Pulgadas									
6	1/4	● BA.48.04.04	7/16	7/16	32	14,2	9,1	14	17	350
8	5/16	● BA.48.05.05	1/2	1/2	34,1	15,5	9,1	16 1)	19	350
10	3/8	● BA.48.06.06	9/16	9/16	35,8	16,4	9,9	17	19	350
12	1/2	● BA.48.08.08	3/4	3/4	40,2	18,5	11,1	22	24	350
14-15-16	5/8	● BA.48.10.10	7/8	7/8	44,2	18,8	12,7	27	27	350
18-20	3/4	● BA.48.12.12	1" 1/16	1" 1/16	49,6	20,3	15,1	32	32	350
25	1"	● BA.48.16.16	1" 5/16	1" 5/16	52,2	22,1	15,1	38 2)	38 2)	280
30-32	1" 1/4	● BA.48.20.20	1" 5/8	1" 5/8	58,1	27,2	15,1	50	50	210
38	1" 1/2	● BA.48.24.24	1" 7/8	1" 7/8	66,9	33,2	15,1	55	60	210

1) AISI 316L CH = 17 2) AISI 316L CH/CH1 = 41



- CORPO: ADATTATORE MASCHIO BSPP (GAS CILINDRICO)
CON DADO GIREVOLE JIC
- CORPS: ADAPTATEUR MALE BSPP (GAZ CYLINDRIQUE)
ECROU PIVOTANT JIC
- BODY: MALE STUD ADAPTOR BSPP (BSP PARALLEL)
WITH ROTARY NUT JIC
- KÖRPER: EINSCHRAUBADAPTER BSPP
(BSP ZYLINDRISCH) MIT DREHMUTTER JIC
- CUERPO: ADAPTADOR MACHO BSPP (GAS CILINDRICO)
CON TUERCA LOCA

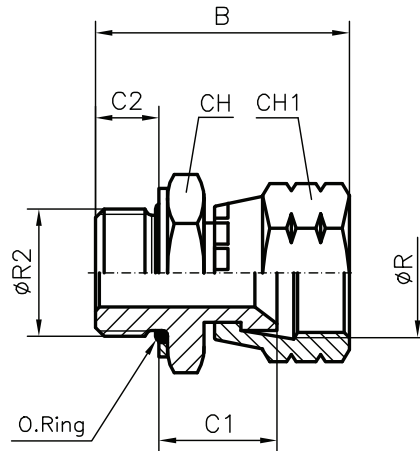

Ø TUBO-TUBE-ROHR		CODICE REFERENCE CODE BEST.-NR. REFERENCIA	Ø R-UNF JIC 37°	Ø R2 BSPP	B	C1	C2	CH	CH1	PN
mm.	Poll. - Pouces Inch. - Zoll Pulgadas									
6	1/4	● BA.49.04.02	7/16	1/8	31,4	16,4	6,3	16 1)	17	350
6	1/4	● BA.49.04.04	7/16	1/4	34,6	16,4	9,5	19	17	350
6	1/4	● BA.49.04.06	7/16	3/8	34,6	16,4	9,5	22	17	350
8	5/16	● BA.49.05.02	1/2	1/8	33,6	17,8	6,3	16 1)	19	350
8	5/16	● BA.49.05.04	1/2	1/4	37,5	18,5	9,5	19	19	350
8	5/16	● BA.49.05.06	1/2	3/8	37,5	18,5	9,5	22	19	350
10	3/8	● BA.49.06.04	9/16	1/4	38	19	9,5	19	19	350
10	3/8	● BA.49.06.06	9/16	3/8	39	20	9,5	22	19	350
10	3/8	● BA.49.06.08	9/16	1/2	42,5	20	13	27	19	350
12	1/2	● BA.49.08.04	3/4	1/4	41,2	21	9,5	19	24	350
12	1/2	● BA.49.08.06	3/4	3/8	41,7	21,5	9,5	22	24	350
12	1/2	● BA.49.08.08	3/4	1/2	46,2	22,5	13	27	24	350
14-15-16	5/8	● BA.49.10.06	7/8	3/8	44,2	22	9,5	22	27	350
14-15-16	5/8	● BA.49.10.08	7/8	1/2	47,9	22,2	13	30	27	350
14-15-16	5/8	● BA.49.10.12	7/8	3/4	47,9	22,2	13	36	27	350
18-20	3/4	● BA.49.12.08	1" 1/16	1/2	50,3	23	13	30	32	350
18-20	3/4	● BA.49.12.12	1" 1/16	3/4	50,3	23	13	36	32	350
18-20	3/4	● BA.49.12.16	1" 1/16	1"	54	23,7	16	46	32	350
25	1"	● BA.49.16.12	1" 5/16	3/4	55,6	27,5	13	36	38 2)	280
25	1"	● BA.49.16.16	1" 5/16	1"	58,6	27,5	16	46	38 2)	280
25	1"	● BA.49.16.20	1" 5/16	1" 1/4	58,6	27,5	16	50	38 2)	280
30-32	1" 1/4	● BA.49.20.16	1" 5/8	1"	61,9	30	16	46	50	210
30-32	1" 1/4	● BA.49.20.20	1" 5/8	1" 1/4	64,9	33	16	50	50	175
38	1" 1/2	● BA.49.24.20	1" 7/8	1" 1/4	70,1	35,5	16	50	60	140
38	1" 1/2	● BA.49.24.24	1" 7/8	1" 1/2	70,1	35,5	16	55	60	140

1) AISI 316L CH = 17 2) AISI 316L CH1 = 41



- CORPO: ADATTATORE MASCHIO (METRICO CILINDRICO)
ISO 6149-3 CON DADO GIREVOLE JIC
- CORPS: ADAPTATEUR MALE (CYLINDRIQUE METRIQUE)
ISO 6149-3 ECROU PIVOTANT JIC
- BODY: MALE STUD ADAPTOR (METRIC PARALLEL)
ISO 6149-3 WITH ROTARY NUT JIC
- KÖRPER: EINSCHRAUBADAPTER (METRISCH ZYLINDRISCH)
ISO 6149-3 MIT DREHMUTTER JIC
- CUERPO: ADAPTADOR MACHO (METRICO CILINDRICO)
ISO 6149-3 CON TUERCA LOCA

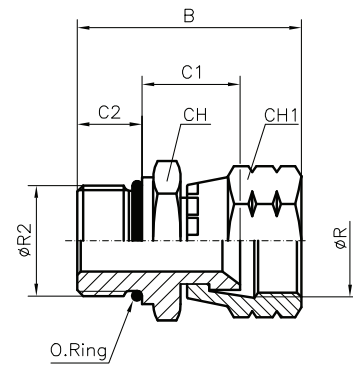

Ø TUBO-TUBE-ROHR		CODICE REFERENCE CODE BEST.-NR. REFERENCIA	Ø R-UNF JIC 37°	Ø R2 Metric Metric Metrisch	B	C1	C2	CH	CH1	PN
mm.	Poll. - Pouces Inch. - Zoll Pulgadas									
6	1/4	● BA.50.04.02	7/16	10x1	33,6	16,4	8,5	16 1)	17	350
8	5/16	● BA.50.05.03	1/2	12x1,5	37,7	17,2	11	19	19	350
10	3/8	● BA.50.06.04	9/16	14x1,5	38,5	18	11	19	19	350
12	1/2	● BA.50.08.05	3/4	16x1,5	43	20,8	11,5	22	24	350
12	1/2	● BA.50.08.06	3/4	18x1,5	44,6	21,4	12,5	24	24	350
14-15-16	5/8	● BA.50.10.06	7/8	18x1,5	46	20,8	12,5	24	27	350
14-15-16	5/8	● BA.50.10.08	7/8	22x1,5	46,5	20,8	13	27	27	350
18-20	3/4	● BA.50.12.08	1" 1/16	22x1,5	52,9	25,6	13	27	32	350
18-20	3/4	● BA.50.12.14	1" 1/16	27x2	54,2	23,9	16	36	32	350
25	1"	● BA.50.16.14	1" 5/16	27x2	56	24,9	16	36	38 2)	280
25	1"	● BA.50.16.16	1" 5/16	33x2	56,3	25,2	16	41	38 2)	280
30-32	1" 1/4	● BA.50.20.20	1" 5/8	42x2	62,6	30,7	16	50	50	210
38	1" 1/2	● BA.50.24.24	1" 7/8	48x2	72	35,9	17,5	55	60	140

1) AISI 316L CH = 17 2) AISI 316L CH1 = 41

- CORPO: ADATTATORE MASCHIO (METRICO CILINDRICO)
RONDELLA TENUTA O-RING CON DADO GIREVOLE JIC
- CORPS: ADAPTATEUR MALE (CYLINDRIQUE METRIQUE)
RONDELLE D'ETANCHEITE O-RING ECROU PIVOTANT JIC
- BODY: MALE STUD ADAPTOR (METRIC PARALLEL)
O-RING SEAL RING WITH ROTARY NUT JIC
- KÖRPER: EINSCHRAUBADAPTER (METRISCH ZYLINDRISCH)
BEWEGLICHE UNTERLEGSCHLEIBE F.O-RING MIT
DREHMUTTER JIC
- CUERPO: ADAPTADOR MACHO (METRICO CILINDRICO)
ARANDELA DE RETENCION JUNTA TONICA
CON TUERCA LOCA

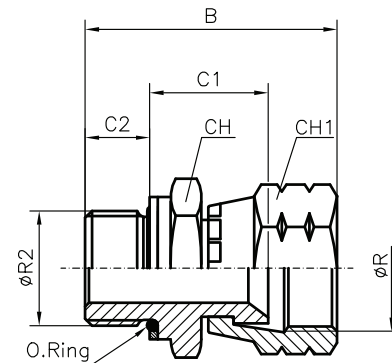

Ø TUBO-TUBE-ROHR		CODICE REFERENCE CODE BEST.-NR. REFERENCIA	Ø R-UNF JIC 37°	Ø R2 Metric Metric Metrisch	B	C1	C2	CH	CH1	PN
mm.	Poll. - Pouces Inch. - Zoll Pulgadas									
6	1/4	● BA.50.04.02 W	7/16	10x1	33,6	17,4	7,5	16 1)	17	350
8	5/16	● BA.50.05.03 W	1/2	12x1,5	37,7	18,7	9,5	19	19	350
10	3/8	● BA.50.06.04 W	9/16	14x1,5	38,5	19,5	9,5	19	19	350
12	1/2	● BA.50.08.05 W	3/4	16x1,5	43	22,3	10	22	24	350
12	1/2	● BA.50.08.06 W	3/4	18x1,5	44,6	22,9	11	24	24	350
14-15-16	5/8	● BA.50.10.06 W	7/8	18x1,5	46	22,3	11	24	27	350
14-15-16	5/8	● BA.50.10.08 W	7/8	22x1,5	46,5	22,3	11,5	27	27	350
18-20	3/4	● BA.50.12.08 W	1" 1/16	22x1,5	52,9	27,1	11,5	27	32	350
18-20	3/4	● BA.50.12.14 W	1" 1/16	27x2	54,2	25,9	14	36	32	350
25	1"	● BA.50.16.14 W	1" 5/16	27x2	56	26,9	14	36	38 2)	250
25	1"	● BA.50.16.16 W	1" 5/16	33x2	56,3	27,2	14	41	38 2)	250
30-32	1" 1/4	● BA.50.20.20 W	1" 5/8	42x2	62,6	32,7	14	50	50	210
38	1" 1/2	● BA.50.24.24 W	1" 7/8	48x2	72	37,9	15,5	55	60	140

1) AISI 316L CH = 17 2) AISI 316L CH1 = 41



ADATTATORE FLANGIA - 3000 PSI
ADAPTATEUR BRIDE - 3000 PSI
FLANGE ADAPTOR - 3000 PSI
FLANSCHADAPTER - 3000 PSI
ADAPTADORA BRIDA - 3000 PSI

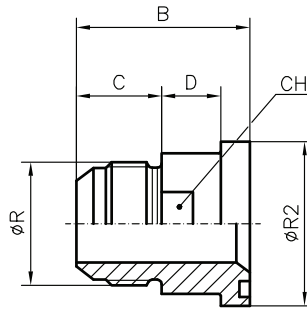

Ø TUBO-TUBE-ROHR		CODICE REFERENCE CODE BEST.-NR. REFERENCIA	Ø R-UNF JIC 37°	Ø R2	B	C	D	CH	PN
mm.	Poll.- Pouces Inch.- Zoll Pulgadas								
12	1/2	BA.51.08.08	3/4	30,2	37,6	16,7	14,3	21	350
18	3/4	BA.51.12.12	1" 1/16	38,1	44,6	21,9	16,1	27	350
20	3/4	BA.51.12.12	1" 1/16	38,1	44,6	21,9	16,1	27	350
25	1"	BA.51.16.16	1" 5/16	44,5	47	23,1	16	34	280
25	1"	BA.51.20.16	1" 5/16	50,8	49	23,1	18	36	280
30	1" 1/4	BA.51.20.20	1" 5/8	50,8	50	24,3	17,8	38	210
32	1" 1/4	BA.51.20.20	1" 5/8	50,8	50	24,3	17,8	38	210
38	1" 1/2	BA.51.24.24	1" 7/8	60,3	53,5	27,5	18,1	45	140

CORPO: UNIONE PASSAPARATIA DIRITTA
CORPS: UNION TRAVERSEE DROITE
BODY: BULKHEAD CONNECTION
KÖRPER: GERADE SCHOTTVERSCHRAUBUNG
CUERPO: UNION PASATABIQUE RECTO

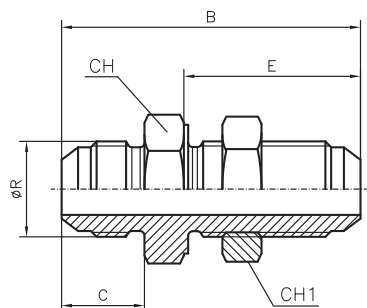

Ø TUBO-TUBE-ROHR		CODICE REFERENCE CODE BEST.-NR. REFERENCIA	Ø R-UNF JIC 37°	B	C	CH	CH1	E	PN
mm.	Poll.- Pouces Inch.- Zoll Pulgadas								
6	1/4	● BA.53.00.04	7/16	52,6	14	17	17	31,5	350
8	5/16	● BA.53.00.05	1/2	52,6	14	19	19	31,5	350
10	3/8	● BA.53.00.06	9/16	55,4	14,1	22	22	33,5	350
12	1/2	● BA.53.00.08	3/4	62	16,7	24	24	37,6	350
14	-	● BA.53.00.10	7/8	69,6	19,3	30	30	41,1	350
15	-	● BA.53.00.10	7/8	69,6	19,3	30	30	41,1	350
16	5/8	● BA.53.00.10	7/8	69,6	19,3	30	30	41,1	350
18	-	● BA.53.00.12	1" 1/16	78,5	21,9	36	36	45,4	350
20	3/4	● BA.53.00.12	1" 1/16	78,5	21,9	36	36	45,4	350
25	1"	● BA.53.00.16	1" 5/16	79,8	23,1	41	41	45,4	280
30	-	● BA.53.00.20	1" 5/8	84,1	24,3	50	50	46,7	210
32	1" 1/4	● BA.53.00.20	1" 5/8	84,1	24,3	50	50	46,7	210
38	1" 1/2	● BA.53.00.24	1" 7/8	89,4	27,5	55	55	47	140

SPESSORE MASSIMO DELLA PARATIA = 9,5 mm.
EPAISSEUR MAX. DE LA CLOISON = 9,5 mm.

MAXIMUM BULKHEAD THICKNESS = 9,5 mm.
MAXIMALE SCHOTTWANDDICKE = 9,5 mm.
ESPESOR MAXIMO DE PARED = 9,5 mm.



- CORPO: UNIONE PASSAPARATIA MASCHIO-FEMMINA BSPP
(GAS CLINDRICO)
- CORPS: UNION TRAVERSEE MALE-FEMELLE BSPP
(GAZ CYLINDRIQUE)
- BODY: BULKHEAD CONNECTION MALE-FEMALE BSPP
(BSP PARALLEL)
- KÖRPER: EIN-AUFSCHRAUB GERADE SCHOTTVERSCHRAUBUNG
BSPP (BSP ZYLINDRISCH)
- CUERPO: UNION PASATABIQUE MACHO-HEMBRA BSPP
(GAS CILINDRICO)

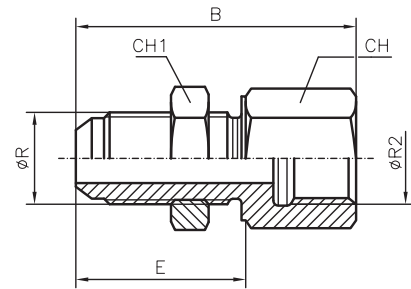

Ø TUBO-TUBE-ROHR		CODICE REFERENCE CODE BEST.-NR. REFERENCIA	Ø R-UNF JIC 37°	Ø R2 BSPP	B	CH	CH1	E	PN
mm.	Poll.- Pouces Inch.- Zoll Pulgadas								
12	1/2	● BA.55.08.06	3/4	3/8	59,6	24	24	37,6	350
14	-	● BA.55.10.08	7/8	1/2	67,8	30	30	41,1	350
15	-	● BA.55.10.08	7/8	1/2	67,8	30	30	41,1	350
16	5/8	● BA.55.10.08	7/8	1/2	67,8	30	30	41,1	350

- CORPO: UNIONE PASSAPARATIA MASCHIO-FEMMINA NPT
UNION TRAVERSÉE
- CORPS: MALE-FEMELLE NPT
- BODY: BULKHEAD CONNECTION MALE-FEMALE NPT
- KÖRPER: EIN-AUFSCHRAUB GERADE
SCHOTTVERSCHRAUBUNG NPT
- CUERPO: UNION PASATABIQUE MACHO-HEMBRA NPT

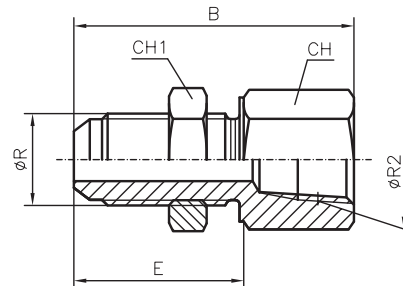

Ø TUBO-TUBE-ROHR		CODICE REFERENCE CODE BEST.-NR. REFERENCIA	Ø R-UNF JIC 37°	Ø R2 NPT	B	CH	CH1	E	PN
mm.	Poll.- Pouces Inch.- Zoll Pulgadas								
6	1/4	● BA.56.04.02	7/16	1/8	46,7	17	17	31,5	350
6	1/4	● BA.56.04.04	7/16	1/4	50,3	19	17	31,5	350
10	3/8	● BA.56.06.04	9/16	1/4	52,3	22	22	33,5	350
12	1/2	● BA.56.08.06	3/4	3/8	59,4	24	24	37,6	350
14	-	● BA.56.10.08	7/8	1/2	67,6	30	30	41,1	350
15	-	● BA.56.10.08	7/8	1/2	67,6	30	30	41,1	350
16	5/8	● BA.56.10.08	7/8	1/2	67,6	30	30	41,1	350
18	-	● BA.56.12.12	1" 1/16	3/4	73,9	36	36	45,4	350
20	3/4	● BA.56.12.12	1" 1/16	3/4	73,9	36	36	45,4	350
25	1"	● BA.56.16.16	1" 5/16	1"	78,5	41	41	45,4	250



CORPO: ADATTATORE FEMMINA
CORPS: ADAPTATEUR FEMELLE
BODY: FEMALE ADAPTOR
KÖRPER: AUFSCHRAUBADAPTER
CUERPO: ADAPTADOR HEMBRA

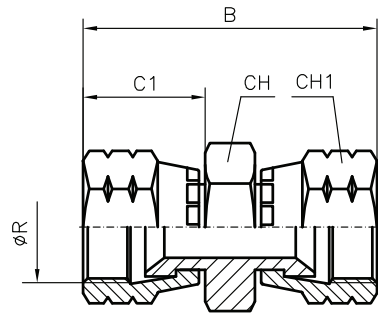

Ø TUBO-TUBE-ROHR		CODICE REFERENCE CODE BEST.-NR. REFERENCIA	Ø R-UNF JIC 37°	B	C1	CH	CH1	PN
mm.	Poll.- Pouces Inch.- Zoll Pulgadas							
12	1/2	● BA.57.00.08	3/4	54,5	24	22	24	350
14-15-16	5/8	● BA.57.00.10	7/8	59,5	26	27	27	350
18-20	3/4	● BA.57.00.12	1" 1/16	67,5	28	32	32	350

CORPO: ADATTATORE MASCHIO BSPP
(GAS CILINDRICO) CON DADO GIREVOLE JIC
GG-GUARNIZIONE GOMMA - FORMA E DIN 3852
CORPS: ADAPTATEUR MALE BSPP
(GAZ CYLINDRIQUE) ECROU PIVOTANT JIC
GG-JOINT EN CAOUTCHOUC - FORME E DIN 3852
BODY: MALE STUD ADAPTOR BSPP
(BSP PARALLEL) WITH ROTARY NUT JIC
GG-RUBBER SEAL - TYPE E DIN 3852
KÖRPER: EINSCHRAUBADAPTER BSPP
(BSP ZYLINDRISCH) MIT DREHMUTTER JIC
GG-GUMMIDICHTUNG - FORM E DIN 3852
CUERPO: ADAPTADOR MACHO BSPP
(GAS CILINDRICO) CON TUERCA LOCA
GG-JUNTA DE GOMA - FORMA E DIN 3852

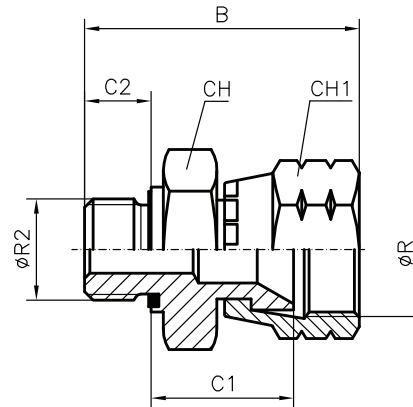

Ø TUBO-TUBE-ROHR		CODICE REFERENCE CODE BEST.-NR. REFERENCIA	Ø R-UNF JIC 37°	Ø R2 BSPP	B	C1	C2	CH	CH1	PN
mm.	Poll.- Pouces Inch.- Zoll Pulgadas									
6	1/4	● BA.58.04.02	7/16	1/8	32,9	16,2	8	14	17	350
6	1/4	● BA.58.04.04	7/16	1/4	37,1	16,4	12	19	17	350
8	5/16	● BA.58.05.02	1/2	1/8	35,5	18	8	14	19	350
8	5/16	● BA.58.05.04	1/2	1/4	40	18,5	12	19	19	350
10	3/8	● BA.58.06.04	9/16	1/4	40,5	19	12	19	19	350
10	3/8	● BA.58.06.06	9/16	3/8	42	20,5	12	22	19	350
12	1/2	● BA.58.08.04	3/4	1/4	44,2	21,5	12	19	24	350
12	1/2	● BA.58.08.06	3/4	3/8	44,7	22	12	22	24	350
14-15-16	5/8	● BA.58.10.06	7/8	3/8	47,4	22,7	12	24	27	350
14-15-16	5/8	● BA.58.10.08	7/8	1/2	49,9	23,2	14	27	27	350
18-20	3/4	● BA.58.12.08	1" 1/16	1/2	52,3	24	14	27	32	350
18-20	3/4	● BA.58.12.12	1" 1/16	3/4	54,3	24	16	32	32	350
25	1"	● BA.58.16.12	1" 5/16	3/4	59,6	28,5	16	32	38 1)	280
25	1"	● BA.58.16.16	1" 5/16	1"	61,6	28,5	18	41	38 1)	280
30-32	1" 1/4	● BA.58.20.16	1" 5/8	1"	67,4	33,5	18	41	50	210
30-32	1" 1/4	● BA.58.20.20	1" 5/8	1" 1/4	69,4	33,5	20	50	50	210
38	1" 1/2	● BA.58.24.20	1" 7/8	1" 1/4	74,6	36	20	50	60	140
38	1" 1/2	● BA.58.24.24	1" 7/8	1" 1/2	76,6	36	22	55	60	140

1) AISI 316L CH1 = 41



- CORPO:** ADATTATORE MASCHIO
METRICO CILINDRICO CON DADO GIREVOLE JIC
GG-GUARNIZIONE GOMMA - FORMA E DIN 3852
- CORPS:** ADAPTATEUR MALE
METRIQUE CYLINDRIQUE ECROU PIVOTANT JIC
GG-JOINT EN CAOUTCHOUC - FORME E DIN 3852
- BODY:** MALE STUD ADAPTOR
METRIC PARALLEL WITH ROTARY NUT JIC
GG-RUBBER SEAL - TYPE E DIN 3852
- KÖRPER:** EINSCHRAUBADAPTER
METRISCH ZYLINDRISCH MIT DREHMUTTER JIC
GG-GUMMIDICHTUNG - FORM E DIN 3852
- CUERPO:** ADAPTADOR MACHO
METRICO CILINDRICO CON TUERCA LOCA
GG-JUNTA DE GOMA - FORMA E DIN 3852

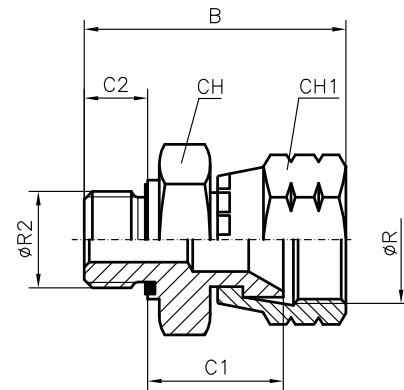

Ø TUBO-TUBE-ROHR		CODICE REFERENCE CODE BEST-NR. REFERENCIA	Ø R-UNF JIC 37°	Ø R2 Metrico Metric Metrisch	B	C1	C2	CH	CH1	PN
mm.	Poll.- Pouces Inch.- Zoll Pulgadas									
6	1/4	● BA.61.04.02	7/16	10x1	32,1	15,4	8	14	17	350
8	5/16	● BA.61.05.03	1/2	12x1,5	38,2	16,7	12	17	19	350
10	3/8	● BA.61.06.04	9/16	14x1,5	39	17,5	12	19	19	350
12	1/2	● BA.61.08.05	3/4	16x1,5	43	20,3	12	22	24	350
12	1/2	● BA.61.08.06	3/4	18x1,5	43,6	20,9	12	24	24	350
14-15-16	5/8	● BA.61.10.06	7/8	18x1,5	45,6	20,9	12	24	27	350
14-15-16	5/8	● BA.61.10.08	7/8	22x1,5	48	21,3	14	27	27	350
18-20	3/4	● BA.61.12.08	1" 1/16	22x1,5	54,4	26,1	14	27	32	350
18-20	3/4	● BA.61.12.14	1" 1/16	27x2	56,7	26,4	16	32	32	350
25	1"	● BA.61.16.16	1" 5/16	33x2	59,5	26,4	18	41	38 1)	280
30-32	1" 1/4	● BA.61.20.20	1" 5/8	42x2	66,6	30,7	20	50	50	210

1) AISI 316L CH 1 = 41

- CORPO:** TERMINALE DIRITTO MASCHIO
UNF - LUNGO
- CORPS:** TERMINAL DROIT MALE
UNF - LONG
- BODY:** STRAIGHT THREAD
CONNECTOR LONG - UNF
- KÖRPER:** FINSCHRAUBVERSCHRAUBUNG UNF
MIT LANGEM SCHAFT
- CUERPO:** ADAPTADOR RECTO MACHO
UNF - PROLONGACIÓN

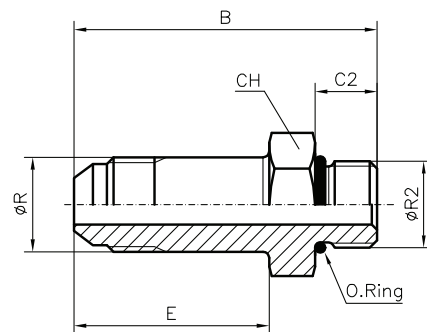

Ø TUBO-TUBE-ROHR		CODICE REFERENCE CODE BEST-NR. REFERENCIA	Ø R-UNF JIC 37°	Ø R2 UNF	B	C2	E	CH	PN
mm.	Poll.- Pouces Inch.- Zoll Pulgadas								
6	1/4	● BA.62.04.04	7/16	7/16	52,8	9,1	35,3	14	350
10	3/8	● BA.62.06.06	9/16	9/16	58,7	9,9	39,6	17	350
12	1/2	● BA.62.08.08	3/4	3/4	68,6	11,1	47,8	22	350
14	-	● BA.62.10.10	7/8	7/8	77,2	12,7	53,1	27	350
15	-	● BA.62.10.10	7/8	7/8	77,2	12,7	53,1	27	350
16	5/8	● BA.62.10.10	7/8	7/8	77,2	12,7	53,1	27	350
18	-	● BA.62.12.12	1" 1/16	1" 1/16	91,7	15,1	63,5	32	350
20	3/4	● BA.62.12.12	1" 1/16	1" 1/16	91,7	15,1	63,5	32	350
25	1"	● BA.62.16.16	1" 5/16	1" 5/16	101	15,1	72,1	38 1)	280
30	-	● BA.62.20.20	1" 5/8	1" 5/8	119,1	15,1	88,1	50	210
32	1" 1/4	● BA.62.20.20	1" 5/8	1" 5/8	119,1	15,1	88,1	50	210

1) AISI 316L CH = 41



CONTRODADO
CONTRE-ECROU
BULKHEAD NUT
GEGENMUTTERN
CONTRATUERCA

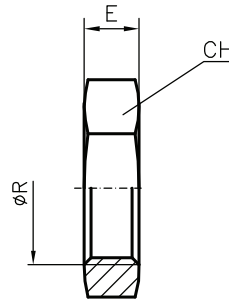

Ø TUBO-TUBE-ROHR		CODICE REFERENCE CODE BEST.-NR. REFERENCIA	Ø R-UNF	E	CH	
mm.	Poll.- Pouces Inch.- Zoll Pulgadas					
6	1/4	● BA.99.00.04	7/16	6,4	17	
8	5/16	● BA.99.00.05	1/2	6,4	19	
10	3/8	● BA.99.00.06	9/16	6,9	22	
12	1/2	● BA.99.00.08	3/4	7,9	24	
14-15-16	5/8	● BA.99.00.10	7/8	9,1	30	
18-20	3/4	● BA.99.00.12	1" 1/16	10,4	36	
25	1"	● BA.99.00.16	1" 5/16	10,4	41	
30-32	1" 1/4	● BA.99.00.20	1" 5/8	10,4	50	
38	1" 1/2	● BA.99.00.24	1" 7/8	10,4	55	

CORPO: UNIONE GOMITO 90°
CORPS: UNION COUDE 90°
BODY: ELBOW COUPLING 90°
KÖRPER: WINKELVERSCHRAUBUNG 90°
CUERPO: UNION CODO 90°

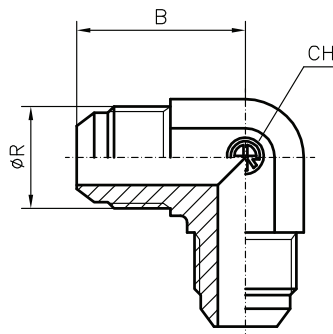

Ø TUBO-TUBE-ROHR		CODICE REFERENCE CODE BEST.-NR. REFERENCIA	Ø R-UNF JIC 37°	B	CH	PN	
mm.	Poll.- Pouces Inch.- Zoll Pulgadas						
6	1/4	● ST. 01.00.04	7/16	22,6	11 1)	350	
8	5/16	● ST. 01.00.05	1/2	24,1	13 2)	350	
10	3/8	● ST. 01.00.06	9/16	26,9	14	350	
12	1/2	● ST. 01.00.08	3/4	31,8	19	350	
14	-	● ST. 01.00.10	7/8	36,8	22	350	
15	-	● ST. 01.00.10	7/8	36,8	22	350	
16	5/8	● ST. 01.00.10	7/8	36,8	22	350	
18	-	● ST. 01.00.12	1" 1/16	42,2	27	350	
20	3/4	● ST. 01.00.12	1" 1/16	42,2	27	350	
25	1"	● ST. 01.00.16	1" 5/16	46	33	280	
30	-	● ST. 01.00.20	1" 5/8	52,3	41	210	
32	1" 1/4	● ST. 01.00.20	1" 5/8	52,3	41	210	
38	1" 1/2	● ST. 01.00.24	1" 7/8	59,2	48	140	

1) - 2) AISI 316L CH = 14 B = 26,9



CORPO: GOMITO MASCHIO 90° BSPP
(GAS CILINDRICO)

CORPS: COUDE MALE 90° BSPP
(GAZ CYLINDRIQUE)

BODY: ELBOW MALE COUPLING 90° BSPP
(BSP PARALLEL)

KÖRPER: WINKELEINSCHRAUBVERSCHRAUBUNG 90° BSPP
(BSP ZYLINDRISCH)

CUERPO: CODO MACHO 90° BSPP
(GAS CILINDRICO)

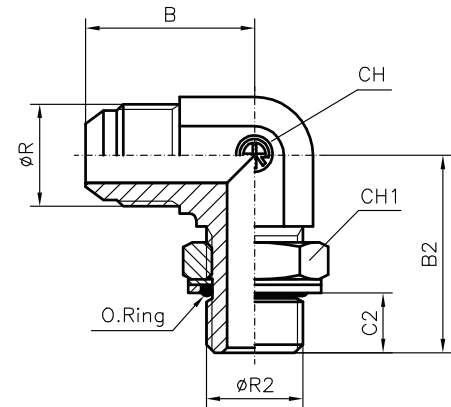

Ø TUBO-TUBE-ROHR		CODICE REFERENCE CODE BEST.-NR. REFERENCIA	Ø R-UNF JIC 37°	Ø R2 BSPP	B	B2	C2	CH	CH1	PN
mm.	Poll.- Pouces Inch.- Zoll Pulgadas									
6	1/4	● ST. 05.04.02	7/16	1/8	22,6	26	6,3	11 1)	14	350
6	1/4	● ST. 05.04.04	7/16	1/4	26,9	32	9,5	14	19	350
6	1/4	● ST. 05.04.06	7/16	3/8	26,9	37	9,5	19	22	350
6	1/4	● ST. 05.04.08	7/16	1/2	26,9	43	13	22	27	350
8	5/16	● ST. 05.05.02	1/2	1/8	24,1	27	6,3	13 2)	14	350
8	5/16	● ST. 05.05.04	1/2	1/4	26,9	32	9,5	14	19	350
8	5/16	● ST. 05.05.06	1/2	3/8	29	37	9,5	19	22	350
10	3/8	● ST. 05.06.04	9/16	1/4	26,9	32	9,5	14	19	350
10	3/8	● ST. 05.06.06	9/16	3/8	29	37	9,5	19	22	350
10	3/8	● ST. 05.06.08	9/16	1/2	31,1	43	13	22	27	350
12	1/2	● ST. 05.08.04	3/4	1/4	31,8	37	9,5	19	19	350
12	1/2	● ST. 05.08.06	3/4	3/8	31,8	37	9,5	19	22	350
12	1/2	● ST. 05.08.08	3/4	1/2	33,7	43	13	22	27	350
12	1/2	● ST. 05.08.12	3/4	3/4	33,7	49,5	13	27	36	350
14	-	● ST. 05.10.06	7/8	3/8	36,8	43	9,5	22	22	350
15	-	● ST. 05.10.06	7/8	3/8	36,8	43	9,5	22	22	350
16	5/8	● ST. 05.10.06	7/8	3/8	36,8	43	9,5	22	22	350
14	-	● ST. 05.10.08	7/8	1/2	36,8	43	13	22	27	250
15	-	● ST. 05.10.08	7/8	1/2	36,8	43	13	22	27	350
16	5/8	● ST. 05.10.08	7/8	1/2	36,8	43	13	22	27	350
14	-	● ST. 05.10.12	7/8	3/4	38,9	49,5	13	27	36	250
15	-	● ST. 05.10.12	7/8	3/4	38,9	49,5	13	27	36	250
16	5/8	● ST. 05.10.12	7/8	3/4	38,9	49,5	13	27	36	250
18	-	● ST. 05.12.08	1" 1/16	1/2	42,2	49,5	13	27	27	350
20	3/4	● ST. 05.12.08	1" 1/16	1/2	42,2	49,5	13	27	27	350
18	-	● ST. 05.12.12	1" 1/16	3/4	42,2	49,5	13	27	36	250
20	3/4	● ST. 05.12.12	1" 1/16	3/4	42,2	49,5	13	27	36	250
18	-	● ST. 05.12.16	1" 1/16	1"	44,8	52	16	33	41	250
20	3/4	● ST. 05.12.16	1" 1/16	1"	44,8	52	16	33	41	250
25	1"	● ST. 05.16.12	1" 5/16	3/4	46	52	16	33	36	250
25	1"	● ST. 05.16.16	1" 5/16	1"	46	52	16	33	41	250
25	1"	● ST. 05.16.20	1" 5/16	1" 1/4	51	57	16	41	50	175
30	-	● ST. 05.20.16	1" 5/8	1"	52,3	57	16	41	41	210
32	1" 1/4	● ST. 05.20.16	1" 5/8	1"	52,3	57	16	41	41	210
30	-	● ST. 05.20.20	1" 5/8	1" 1/4	52,3	57	16	41	50	175
32	1" 1/4	● ST. 05.20.20	1" 5/8	1" 1/4	52,3	57	16	41	50	175
38	1" 1/2	● ST. 05.24.20	1" 7/8	1" 1/4	59,2	60,5	16	48	50	140
38	1" 1/2	● ST. 05.24.24	1" 7/8	1" 1/2	59,2	60,5	16	48	55	140

1) - 2) Al31 316L CH = 14 B = 26,9 B2 = 28,5



CORPO: GOMITO MASCHIO 90° UNF 2A
CORPS: COUDE MALE 90° UNF 2A
BODY: ELBOW MALE COUPLING 90° UNF 2A
KÖRPER: WINKELEINSCHRAUBVERSCHRAUBUNG 90° UNF 2A
CUERPO: CODO MACHO 90° UNF 2A

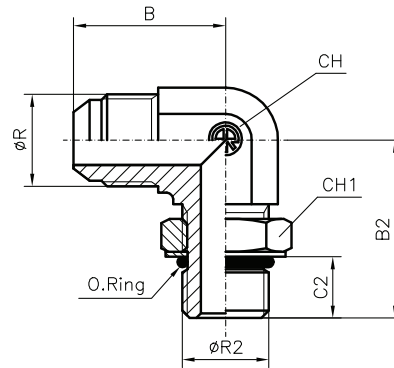

Ø TUBO-TUBE-ROHR		CODICE REFERENCE CODE BEST.-NR. REFERENCIA	Ø R-UNF JIC 37°	Ø R2 UNF	B	B2	C2	CH	CH1	PN
mm.	Poll.- Pouces Inch.- Zoll Pulgadas									
6	1/4	● ST. 06.04.04	7/16	7/16	22,6	26,2	9	11 1)	14	350
6	1/4	● ST. 06.04.06	7/16	9/16	26,9	31,8	10	14	17	350
8	5/16	● ST. 06.05.05	1/2	1/2	24,1	27,7	9	13 2)	16 3)	350
8	5/16	● ST. 06.05.06	1/2	9/16	26,9	31,8	10	14	17	350
10	3/8	● ST. 06.06.04	9/16	7/16	26,9	30,8	9	14	14	350
10	3/8	● ST. 06.06.05	9/16	1/2	26,9	30,8	9	14	16 3)	350
10	3/8	● ST. 06.06.06	9/16	9/16	26,9	31,8	10	14	17	350
10	3/8	● ST. 06.06.08	9/16	3/4	29	36,8	11	19	22	350
10	3/8	● ST. 06.06.10	9/16	7/8	31	43,2	12,7	22	27	350
12	1/2	● ST. 06.08.06	3/4	9/16	31,8	33,5	10	19	17	350
12	1/2	● ST. 06.08.08	3/4	3/4	31,8	36,8	11	19	22	350
12	1/2	● ST. 06.08.10	3/4	7/8	34	43,2	12,7	22	27	350
12	1/2	● ST. 06.08.12	3/4	1" 1/16	36,8	49,3	15	27	32	350
14	-	● ST. 06.10.08	7/8	3/4	36,8	39,1	11	22	22	350
15	-	● ST. 06.10.08	7/8	3/4	36,8	39,1	11	22	22	250
16	5/8	● ST. 06.10.08	7/8	3/4	36,8	39,1	11	22	22	350
14	-	● ST. 06.10.10	7/8	7/8	36,8	43,2	12,7	22	27	350
15	-	● ST. 06.10.10	7/8	7/8	36,8	43,2	12,7	22	27	350
16	5/8	● ST. 06.10.10	7/8	7/8	36,8	43,2	12,7	22	27	350
14	-	● ST. 06.10.12	7/8	1" 1/16	39,2	49,3	15	27	32	350
15	-	● ST. 06.10.12	7/8	1" 1/16	39,2	49,3	15	27	32	350
16	5/8	● ST. 06.10.12	7/8	1" 1/16	39,2	49,3	15	27	32	350
18	-	● ST. 06.12.08	1" 1/16	3/4	42,2	41,2	11	27	22	350
20	3/4	● ST. 06.12.08	1" 1/16	3/4	42,2	41,2	11	27	22	350
18	-	● ST. 06.12.10	1" 1/16	7/8	42,2	45,2	12,7	27	27	350
20	3/4	● ST. 06.12.10	1" 1/16	7/8	42,2	45,2	12,7	27	27	350
18	-	● ST. 06.12.12	1" 1/16	1" 1/16	42,2	49,3	15	27	32	350
20	3/4	● ST. 06.12.12	1" 1/16	1" 1/16	42,2	49,3	15	27	32	350
18	-	● ST. 06.12.16	1" 1/16	1" 5/16	44,7	52,1	15	33	38 4)	350
20	3/4	● ST. 06.12.16	1" 1/16	1" 5/16	44,7	52,1	15	33	38 4)	350
25	1"	● ST. 06.16.12	1" 5/16	1" 1/16	46	52,1	15	33	32	280
25	1"	● ST. 06.16.16	1" 5/16	1" 5/16	46	52,1	15	33	38 4)	280
25	1"	● ST. 06.16.20	1" 5/16	1" 5/8	52,3	57,2	15	41	50	210
30	-	● ST. 06.20.20	1" 5/8	1" 5/8	52,3	57,2	15	41	50	210
32	1" 1/4	● ST. 06.20.20	1" 5/8	1" 5/8	52,3	57,2	15	41	50	210
38	1" 1/2	● ST. 06.24.24	1" 7/8	1" 7/8	59,2	60,7	15	48	55	140

1) - 2) AISI 316L CH = 14 B = 26,9 B2 = 30,8
3) AISI 316L CH 1 = 17 4) AISI 316L CH 1 = 41



CORPO: GOMITO MASCHIO 90°
METRICO ISO 6149-3

CORPS: COUDE MALE 90° METRIQUE
ISO 6149-3

BODY: ELBOW MALE COUPLING 90°
METRIC ISO 6149-3

KÖRPER: WINKELEINSCHRAUBVERSCHRAUBUNG 90°
METRISCH ISO 6149-3

CUERPO: CODO MACHO 90°
METRICO ISO 6149-3

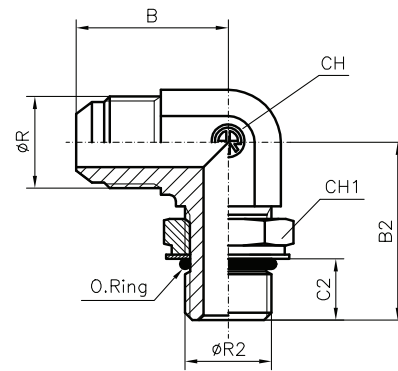

Ø TUBO-TUBE-ROHR		CODICE REFERENCE CODE BEST.-NR. REFERENCIA	Ø R-UNF JIC 37°	Ø R2 Metrico Metric Metrisch	B	B2	C2	CH	CH1	PN
mm.	Poll.- Pouces Inch.- Zoll Pulgadas									
6	1/4	● ST. 07.04.02	7/16	10x1	22,6	27	8,5	11 1)	14	350
6	1/4	● ST. 07.04.03	7/16	12x1,5	24,1	29	11	14	17	350
8	5/16	● ST. 07.05.02	1/2	10x1	26,9	27,5	8,5	14	14	350
8	5/16	● ST. 07.05.03	1/2	12x1,5	24,1	29	11	13 2)	17	350
8	5/16	● ST. 07.05.04	1/2	14x1,5	26,9	32	11	14	19	350
10	3/8	● ST. 07.06.04	9/16	14x1,5	26,9	34	11	14	19	350
10	3/8	● ST. 07.06.05	9/16	16x1,5	29	36	11,5	19	22	350
12	1/2	● ST. 07.08.05	3/4	16x1,5	31,8	36	11,5	19	22	350
12	1/2	● ST. 07.08.06	3/4	18x1,5	31,8	38	12,5	19	24	350
14	-	● ST. 07.10.06	7/8	18x1,5	36,8	41,5	12,5	22	24	350
15	-	● ST. 07.10.06	7/8	18x1,5	36,8	41,5	12,5	22	24	350
16	5/8	● ST. 07.10.06	7/8	18x1,5	36,8	41,5	12,5	22	24	350
14	-	● ST. 07.10.07	7/8	20x1,5	36,8	42,5	12,5	22	27	350
15	-	● ST. 07.10.07	7/8	20x1,5	36,8	42,5	12,5	22	27	350
16	5/8	● ST. 07.10.07	7/8	20x1,5	36,8	42,5	12,5	22	27	350
14	-	● ST. 07.10.08	7/8	22x1,5	36,8	42,5	12,5	22	27	350
15	-	● ST. 07.10.08	7/8	22x1,5	36,8	42,5	12,5	22	27	350
16	5/8	● ST. 07.10.08	7/8	22x1,5	36,8	42,5	12,5	22	27	350
18	-	● ST. 07.12.08	1" 1/16	22x1,5	42,2	45	12,5	27	27	350
20	3/4	● ST. 07.12.08	1" 1/16	22x1,5	42,2	45	12,5	27	27	350
18	-	● ST. 07.12.14	1" 1/16	27x2	42,2	51	15,5	27	32	350
20	3/4	● ST. 07.12.14	1" 1/16	27x2	42,2	51	15,5	27	32	350
25	1"	● ST. 07.16.14	1" 5/16	27x2	46	53	15,5	33	32	280
25	1"	● ST. 07.16.16	1" 5/16	33x2	46	53	15,5	33	41	280
30	-	● ST. 07.20.20	1" 5/8	42x2	52,3	58	15,5	41	50	210
32	1" 1/4	● ST. 07.20.20	1" 5/8	42x2	52,3	58	15,5	41	50	210
38	1" 1/2	● ST. 07.24.24	1" 7/8	48x2	59,2	63,5	17	48	55	140

1) - 2) AISI 316L CH = 14 B = 26,9 B2 = 31,5/34



- CORPO: GOMITO MASCHIO 90° METRICO -
RONDELLA TENUTA O-RING
- CORPS: COUDE MALE 90° METRIQUE -
RONDELLE D'ETANCHEITE O-RING
- BODY: ELBOW MALE COUPLING 90° METRIC -
O-RING SEAL RING
- KÖRPER: WINKELEINSCHRAUBVERSCHRAUBUNG 90° METRISCH -
BEWEGLICHE UNTERLEGSSCHEIBE F.O-RING
- CUERPO: CODO MACHO 90° METRICO -
ARANDELA DE RETENCION JUNTA TORICA

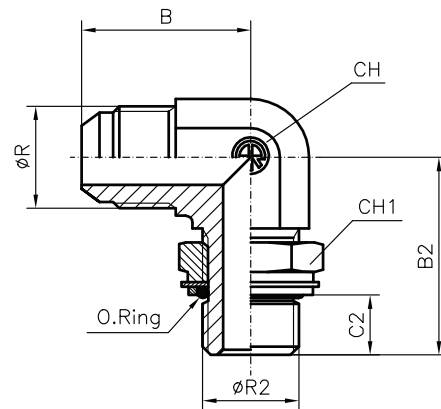

Ø TUBO-TUBE-ROHR		CODICE REFERENCE CODE BEST.-NR. REFERENCIA	Ø R-UNF JIC 37°	Ø R2 Metrico Metrique Metric Metrisch	B	B2	C2	CH	CH1	PN
mm.	Poll.- Pouces Inch.- Zoll Pulgadas									
6	1/4	● ST. 07.04.02 W	7/16	10x1	22,6	27	7,5	11 1)	14	350
6	1/4	● ST. 07.04.03 W	7/16	12x1,5	24,1	29	9,5	11 1)	17	350
8	5/16	● ST. 07.05.02 W	1/2	10x1	26,9	26	7,5	14	14	350
8	5/16	● ST. 07.05.03 W	1/2	12x1,5	24,1	29	9,5	13 2)	17	350
8	5/16	● ST. 07.05.04 W	1/2	14x1,5	26,9	34	9,5	14	19	350
10	3/8	● ST. 07.06.04 W	9/16	14x1,5	26,9	34	9,5	14	19	350
10	3/8	● ST. 07.06.05 W	9/16	16x1,5	26,9	36	10	19	22	350
12	1/2	● ST. 07.08.05 W	3/4	16x1,5	31,8	36	10	19	22	350
12	1/2	● ST. 07.08.06 W	3/4	18x1,5	31,8	38	11	19	24	350
14	-	● ST. 07.10.06 W	7/8	18x1,5	36,8	41,5	11	22	24	350
15	-	● ST. 07.10.06 W	7/8	18x1,5	36,8	41,5	11	22	24	350
16	5/8	● ST. 07.10.06 W	7/8	18x1,5	36,8	41,5	11	22	24	350
14	-	● ST. 07.10.07 W	7/8	20x1,5	36,8	42,5	11	22	27	350
15	-	● ST. 07.10.07 W	7/8	20x1,5	36,8	42,5	11	22	27	350
16	5/8	● ST. 07.10.07 W	7/8	20x1,5	36,8	42,5	11	22	27	350
14	-	● ST. 07.10.08 W	7/8	22x1,5	36,8	42,5	11	22	27	350
15	-	● ST. 07.10.08 W	7/8	22x1,5	36,8	42,5	11	22	27	350
16	5/8	● ST. 07.10.08 W	7/8	22x1,5	36,8	42,5	11	22	27	350
18	-	● ST. 07.12.08 W	1" 1/16	22x1,5	42,2	45	11	27	27	350
20	3/4	● ST. 07.12.08 W	1" 1/16	22x1,5	42,2	45	11	27	27	350
18	-	● ST. 07.12.14 W	1" 1/16	27x2	42,2	51	13,5	27	32	350
20	3/4	● ST. 07.12.14 W	1" 1/16	27x2	42,2	51	13,5	27	32	350
25	1"	● ST. 07.16.14 W	1" 5/16	27x2	46	53	13,5	33	32	250
25	1"	● ST. 07.16.16 W	1" 5/16	33x2	46	53	13,5	33	41	250
30	-	● ST. 07.20.20 W	1" 5/8	42x2	52,3	58	13,5	41	50	210
32	1" 1/4	● ST. 07.20.20 W	1" 5/8	42x2	52,3	58	13,5	41	50	210
38	1" 1/2	● ST. 07.24.24 W	1" 7/8	48x2	59,2	63,5	17	48	55	140

1) - 2) AISI 316L CH = 14 B = 26,9 B2 = 31,5/34



CORPO: UNIONE GOMITO 90°
CON DADO GIREVOLE JIC

CORPS: UNION COUDE 90°
ECROU PIVOTANT JIC

BODY: ELBOW COUPLING 90°
WITH ROTARY NUT JIC

KÖRPER: WINKELEINSCHRAUBVERSCHRAUBUNG 90°
MITDREHMUTTERJIC

CUERPO: CODO MACHO 90°
CON TUERCA LOCA JIC

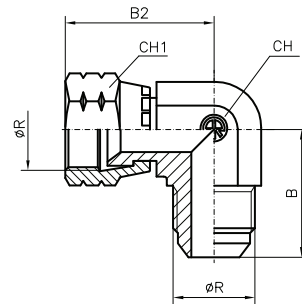

Ø TUBO-TUBE-ROHR		CODICE REFERENCE CODE BEST.-NR. REFERENCIA	Ø R-UNF JIC 37°	B	B2	CH	CH1	PN	
mm.	Poll.- Pouces Inch.- Zoll Pulgadas								
6	1/4	● ST. 09.00.04	7/16	22,6	25,7	11 1)	17	350	
8	5/16	● ST. 09.00.05	1/2	24,1	28	13 2)	19	350	
10	3/8	● ST. 09.00.06	9/16	26,9	32,5	14	19	350	
12	1/2	● ST. 09.00.08	3/4	31,8	36,2	19	24	350	
14	-	● ST. 09.00.10	7/8	36,8	41,2	22	27	350	
15	-	● ST. 09.00.10	7/8	36,8	41,2	22	27	350	
16	5/8	● ST. 09.00.10	7/8	36,8	41,2	22	27	350	
18	-	● ST. 09.00.12	1" 1/16	42,2	46	27	32	350	
20	3/4	● ST. 09.00.12	1" 1/16	42,2	46	27	32	350	
25	1"	● ST. 09.00.16	1" 5/16	46	51,6	33	38 3)	280	
30	-	● ST. 09.00.20	1" 5/8	52,3	59,9	41	50	210	
32	1" 1/4	● ST. 09.00.20	1" 5/8	52,3	59,9	41	50	210	
38	1" 1/2	● ST. 09.00.24	1" 7/8	59,2	63,5	48	60	140	

1) - 2) AISI 316L CH = 14 B = 26,9 B2 = 28,5/30 3) AISI 316L CH1 = 41

CORPO: GOMITO MASCHIO 90°
NPT - LUNGO

CORPS: COUDE MALE 90°
NPT - LONG

BODY: ELBOW MALE COUPLING 90°
NPT - LONG

KÖRPER: WINKELEINSCHRAUBVERSCHRAUBUNG 90°
MIT LANGEM SCHAFT - NPT

CUERPO: CODO MACHO 90°
NPT - PROLONGACIÓN

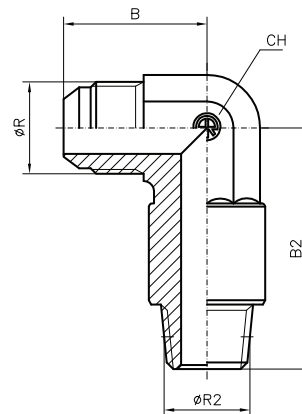

Ø TUBO-TUBE-ROHR		CODICE REFERENCE CODE BEST.-NR. REFERENCIA	Ø R-UNF JIC 37°	Ø R2 NPT	B	B2	CH	PN	
mm.	Poll.- Pouces Inch.- Zoll Pulgadas								
6	1/4	ST. 10.04.04	7/16	1/4	22,6	40,1	14	350	
8	5/16	ST. 10.05.02	1/2	1/8	24,1	30,7	14	350	
10	3/8	ST. 10.06.04	9/16	1/4	26,9	40,1	14	350	
12	1/2	ST. 10.08.06	3/4	3/8	31,8	46,2	19	350	
12	1/2	ST. 10.08.08	3/4	1/2	33,8	55,1	22	350	
14	-	ST. 10.10.08	7/8	1/2	36,8	55,1	22	350	
15	-	ST. 10.10.08	7/8	1/2	36,8	55,1	22	350	
16	5/8	ST. 10.10.08	7/8	1/2	36,8	55,1	22	350	
18	-	ST. 10.12.12	1" 1/16	3/4	42,2	62	27	350	
20	3/4	ST. 10.12.12	1" 1/16	3/4	42,2	62	27	350	
25	1"	ST. 10.16.16	1" 5/16	1"	46	72,5	33	280	



CORPO: GOMITO MASCHIO 90° NPT
 CORPS: COUDE MALE 90° NPT
 BODY: ELBOW MALE COUPLING 90° NPT
 KÖRPER: WINKELEINSCHRAUBVERSCHRAUBUNG 90° NPT
 CUERPO: CODO MACHO 90° NPT

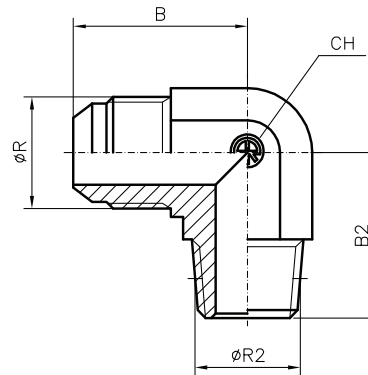

Ø TUBO-TUBE-ROHR		CODICE REFERENCE CODE BEST.-NR. REFERENCIA	Ø R-UNF JIC 37°	Ø R2 NPT	B	B2	CH	PN	
mm.	Poll.- Pouces Inch.- Zoll Pulgadas								
6	1/4	● ST. 11.04.02	7/16	1/8	22,6	19,8	11 1)	350	
6	1/4	● ST. 11.04.04	7/16	1/4	26,9	27,7	14	350	
6	1/4	● ST. 11.04.06	7/16	3/8	28,5	29,7	19	350	
6	1/4	● ST. 11.04.08	7/16	1/2	31	36,5	22	350	
8	5/16	● ST. 11.05.02	1/2	1/8	24,1	19,8	13 2)	350	
8	5/16	● ST. 11.05.04	1/2	1/4	26,9	27,7	14	350	
10	3/8	● ST. 11.06.02	9/16	1/8	26,9	22,8	14	350	
10	3/8	● ST. 11.06.04	9/16	1/4	26,9	27,7	14	350	
10	3/8	● ST. 11.06.06	9/16	3/8	29	31	19	350	
10	3/8	● ST. 11.06.08	9/16	1/2	31,2	37,3	22	350	
12	1/2	● ST. 11.08.04	3/4	1/4	31,8	31	19	350	
12	1/2	● ST. 11.08.06	3/4	3/8	31,8	31	19	350	
12	1/2	● ST. 11.08.08	3/4	1/2	33,7	37,3	22	350	
12	1/2	● ST. 11.08.12	3/4	3/4	36	40,4	27	350	
14	-	● ST. 11.10.06	7/8	3/8	36,8	33	22	350	
15	-	● ST. 11.10.06	7/8	3/8	36,8	33	22	350	
16	5/8	● ST. 11.10.06	7/8	3/8	36,8	37,3	22	350	
14	-	● ST. 11.10.08	7/8	1/2	36,8	37,3	22	350	
15	-	● ST. 11.10.08	7/8	1/2	36,8	37,3	22	350	
16	5/8	● ST. 11.10.08	7/8	1/2	36,8	37,3	22	350	
14	-	● ST. 11.10.12	7/8	3/4	38,9	40,4	27	350	
15	-	● ST. 11.10.12	7/8	3/4	38,9	40,4	27	350	
16	5/8	● ST. 11.10.12	7/8	3/4	42,2	40,4	27	350	
18	-	● ST. 11.12.08	1" 1/16	1/2	42,2	40,4	27	350	
20	3/4	● ST. 11.12.08	1" 1/16	1/2	42,2	40,4	27	350	
18	-	● ST. 11.12.12	1" 1/16	3/4	42,2	40,4	27	350	
20	3/4	● ST. 11.12.12	1" 1/16	3/4	42,2	40,4	27	350	
18	-	● ST. 11.12.16	1" 1/16	1"	44,7	50	33	280	
20	3/4	● ST. 11.12.16	1" 1/16	1"	44,7	50	33	280	
25	1"	● ST. 11.16.12	1" 5/16	3/4	46	45,2	33	280	
25	1"	● ST. 11.16.16	1" 5/16	1"	46	50	33	280	
25	1"	● ST. 11.16.20	1" 5/16	1" 1/4	54	59,6	41	280	
30	-	● ST. 11.20.16	1" 5/8	1"	52,3	59,6	41	210	
32	1" 1/4	● ST. 11.20.16	1" 5/8	1"	52,3	59,6	41	210	
30	-	● ST. 11.20.20	1" 5/8	1" 1/4	52,3	59,6	41	210	
32	1" 1/4	● ST. 11.20.20	1" 5/8	1" 1/4	52,3	59,6	41	210	
30	-	● ST. 11.20.24	1" 5/8	1" 1/2	56	67,1	48	140	
32	1" 1/4	● ST. 11.20.24	1" 5/8	1" 1/2	56	67,1	48	140	
38	1" 1/2	● ST. 11.24.20	1" 7/8	1" 1/4	59,2	57	48	140	
38	1" 1/2	● ST. 11.24.24	1" 7/8	1" 1/2	59,2	67,1	48	140	

1) - 2) AISI 316L CH = 14 B = 26,9



CORPO: GOMITO MASCHIO 90°
BSPT (GAS CONICO)

CORPS: COUDE MALE 90°
BSPT (GAZ CONIQUE)

BODY: ELBOW MALE COUPLING 90°
BSPT (BSP TAPERED)

KÖRPER: WINKELEINSCHRAUBVERSCHRAUBUNG 90°
BSPT

CUERPO: CODO MACHO 90°
BSPT (GAS CONICO)

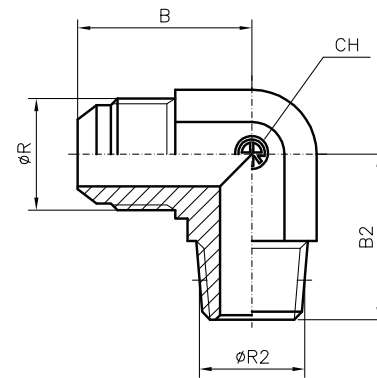

Ø TUBO-TUBE-ROHR		CODICE REFERENCE CODE BEST.-NR. REFERENCIA	Ø R-UNF JIC 37°	Ø R2 BSPT	B	B2	CH	PN	
mm.	Poll.- Pouces Inch.- Zoll Pulgadas								
6	1/4	● ST. 12.04.02	7/16	1/8	22,6	19,8	11 1)	350	
6	1/4	● ST. 12.04.04	7/16	1/4	26,9	27,7	14	350	
8	5/16	● ST. 12.05.02	1/2	1/8	24,1	19,8	13 2)	350	
8	5/16	● ST. 12.05.04	1/2	1/4	26,9	27,7	14	350	
10	3/8	● ST. 12.06.02	9/16	1/8	26,9	22,8	14	350	
10	3/8	● ST. 12.06.04	9/16	1/4	26,9	27,7	14	350	
10	3/8	● ST. 12.06.06	9/16	3/8	29	31	19	350	
10	3/8	● ST. 12.06.08	9/16	1/2	31,2	37,3	22	350	
12	1/2	● ST. 12.08.04	3/4	1/4	31,8	31	19	350	
12	1/2	● ST. 12.08.06	3/4	3/8	31,8	31	19	350	
12	1/2	● ST. 12.08.08	3/4	1/2	33,7	37,3	22	350	
12	1/2	● ST. 12.08.12	3/4	3/4	36	40,4	27	350	
14	-	● ST. 12.10.06	7/8	3/8	36,8	33	22	350	
15	-	● ST. 12.10.06	7/8	3/8	36,8	33	22	350	
16	5/8	● ST. 12.10.06	7/8	3/8	36,8	33	22	350	
14	-	● ST. 12.10.08	7/8	1/2	36,8	37,3	22	350	
15	-	● ST. 12.10.08	7/8	1/2	36,8	37,3	22	350	
16	5/8	● ST. 12.10.08	7/8	1/2	36,8	37,3	22	350	
14	-	● ST. 12.10.12	7/8	3/4	38,9	40,4	27	350	
15	-	● ST. 12.10.12	7/8	3/4	38,9	40,4	27	350	
16	5/8	● ST. 12.10.12	7/8	3/4	38,9	40,4	27	350	
18	-	● ST. 12.12.08	1" 1/16	1/2	42,2	40,4	27	350	
20	3/4	● ST. 12.12.08	1" 1/16	1/2	42,2	40,4	27	350	
18	-	● ST. 12.12.12	1" 1/16	3/4	42,2	40,4	27	350	
20	3/4	● ST. 12.12.12	1" 1/16	3/4	42,2	40,4	27	350	
18	-	● ST. 12.12.16	1" 1/16	1"	44,7	50	33	280	
20	3/4	● ST. 12.12.16	1" 1/16	1"	44,7	50	33	280	
25	1"	● ST. 12.16.12	1" 5/16	3/4	46	45,2	33	280	
25	1"	● ST. 12.16.16	1" 5/16	1"	46	50	33	280	
30	-	● ST. 12.20.16	1" 5/8	1"	52,3	59,6	41	210	
32	1" 1/4	● ST. 12.20.16	1" 5/8	1"	52,3	59,6	41	210	
30	-	● ST. 12.20.20	1" 5/8	1" 1/4	52,3	59,6	41	210	
32	1" 1/4	● ST. 12.20.20	1" 5/8	1" 1/4	52,3	59,6	41	210	
38	1" 1/2	● ST. 12.24.24	1" 7/8	1" 1/2	59,2	67,1	48	140	

1) - 2) AISI 316L CH = 14 B = 26,9



CORPO: UNIONE PASSAPARATIA GOMITO 90°
CORPS: UNION TRAVERSEE COUDE 90°
BODY: BULKHEAD ELBOW 90°
KÖRPER: WINKELSCHOTTVERSCHRAUBUNG 90°
CUERPO: UNION PASATABIQUE CODO 90°

SPESSORE MAX DELLA PARATIA = 5 mm.
EPAISSEUR MAX DE LA CLOISON = 5 mm.
MAXIMUM BULKHEAD THICKNESS = 5 mm.
MAXIMALE SCHOTTWANDDIECKE = 5 mm.
ESPESOR MAXIMO DE PARED = 5 mm.

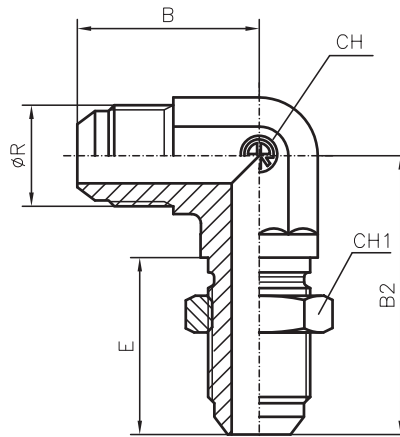

Ø TUBO-TUBE-ROHR		CODICE REFERENCE CODE BEST.-NR. REFERENCIA	Ø R-UNF JIC 37°	B	B2	CH	CH1	E	PN
mm.	Poll.- Pouces Inch.- Zoll Pulgadas								
6	1/4	ST. 13.00.04	7/16	26,9	40,4	14	17	28,3	350
8	5/16	ST. 13.00.05	1/2	27	43,7	14	19	28,3	350
10	3/8	ST. 13.00.06	9/16	27,7	46	14	22	30,1	350
12	1/2	ST. 13.00.08	3/4	34,5	53,6	19	24	35	350
14	-	ST. 13.00.10	7/8	39,6	60,7	22	30	38,5	350
15	-	ST. 13.00.10	7/8	39,6	60,7	22	30	38,5	350
16	5/8	ST. 13.00.10	7/8	39,6	60,7	22	30	38,5	350
18	-	ST. 13.00.12	1" 1/16	45,2	67,8	27	36	42,8	350
20	3/4	ST. 13.00.12	1" 1/16	45,2	67,8	27	36	42,8	350
25	1"	ST. 13.00.16	1" 5/16	49,3	71,1	33	41	42,8	280
30-32	1" 1/4	ST. 13.00.20	1" 5/8	55,1	79,2	41	50	44,1	210
38	1" 1/2	ST. 13.00.24	1" 7/8	59,4	86,9	48	55	44,3	140

CORPO: GOMITO 90° SALDABILE
CORPS: COUDE 90° A SOUDER
BODY: WELDING ELBOW 90°
KÖRPER: ANSCHWEISSWINKEL 90°
CUERPO: CODO 90° SOLDABLE

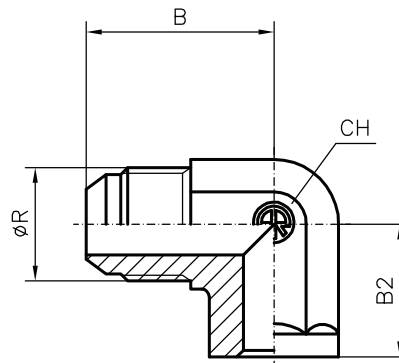

Ø TUBO-TUBE-ROHR		CODICE REFERENCE CODE BEST.-NR. REFERENCIA	Ø R-UNF JIC 37°	B	B2	CH	PN
mm.	Poll.- Pouces Inch.- Zoll Pulgadas						
6	1/4	● ST. 15.00.04	7/16	22,6	20	13/14 1)	350
8	5/16	● ST. 15.00.05	1/2	24,1	20	13 1)	350
10	3/8	● ST. 15.00.06	9/16	26,9	22	14	350
12	1/2	● ST. 15.00.08	3/4	31,8	22	19	350
14	-	● ST. 15.00.10	7/8	36,8	26	22	350
15	-	● ST. 15.00.10	7/8	36,8	26	22	350
16	5/8	● ST. 15.00.10	7/8	36,8	26	22	350
18-20	3/4	● ST. 15.00.12	1" 1/16	42,2	30	27	350
25	1	● ST. 15.00.16	1" 5/16	46	36	33	280
30-32	1" 1/4	● ST. 15.00.20	1" 5/8	52,3	38	41	210
38	1" 1/2	● ST. 15.00.24	1" 7/8	59,2	45	48	140

1) AISI 316L CH = 14 B = 26,9



CORPO: GOMITO 90° FEMMINA NPT
CORPS: COUDE 90° FEMELLE NPT
BODY: ELBOW 90° FEMALE NPT
KÖRPER: WINKELVERSCHRAUBUNG 90° MUTTERSETTING NPT
CUERPO: CODO 90° HEMBRA NPT

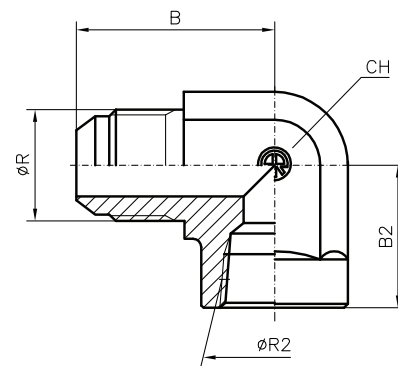

Ø TUBO-TUBE-ROHR		CODICE REFERENCE CODE BEST.-NR. REFERENCIA	Ø R-UNF JIC 37°	Ø R2 NPT	B	B2	CH	PN	
mm.	Poll.-Pouces Inch.- Zoll Pulgadas								
6	1/4	● ST. 17.04.02	7/16	1/8	27,4	16,8	14	350	
6	1/4	● ST. 17.04.04	7/16	1/4	31	22,4	19	350	
8	5/16	● ST. 17.05.02	1/2	1/8	27,4	16,8	14	350	
8	5/16	● ST. 17.05.04	1/2	1/4	28,7	22,4	19	350	
10	3/8	● ST. 17.06.02	9/16	1/8	31,2	17	14	350	
10	3/8	● ST. 17.06.04	9/16	1/4	31,2	22,4	19	350	
10	3/8	● ST. 17.06.06	9/16	3/8	33,3	25,9	22	350	
12	1/2	● ST. 17.08.04	3/4	1/4	36,1	25,9	19	350	
12	1/2	● ST. 17.08.06	3/4	3/8	36,1	25,9	22	350	
12	1/2	● ST. 17.08.08	3/4	1/2	38,7	31,2	27	350	
14-15-16	5/8	● ST. 17.10.08	7/8	1/2	41,7	31,2	27	350	
18-20	3/4	● ST. 17.12.08	1" 1/16	1/2	48	34,5	27	250	
18-20	3/4	● ST. 17.12.12	1" 1/16	3/4	48	34,5	33	350	
25	1"	● ST. 17.16.16	1" 5/16	1"	55,1	41,4	41	250	
30-32	1" 1/4	● ST. 17.20.20	1" 5/8	1" 1/4	59,2	43,2	48	210	



CORPO: GOMITO MASCHIO 45° BSPP
(GAS CILINDRICO)

CORPS: COUDE MALE 45° BSPP
(GAZ CYLINDRIQUE)

BODY: ELBOW MALE COUPLING 45° BSPP
(BSP PARALLEL)

KÖRPER: WINKLEINSCHRAUBVERSCHRAUBUNG 45° BSPP
(BSP ZYLINDRISCH)

CUERPO: CODO MACHO 45° BSPP
(GAS CILINDRICO)

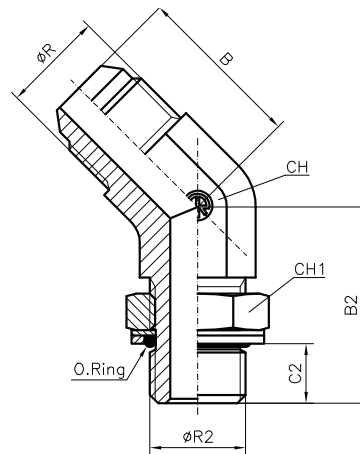

Ø TUBO-TUBE-ROHR		CODICE REFERENCE CODE BEST.-NR. REFERENCIA	Ø R-UNF JIC 37°	Ø R2 BSPP	B	B2	C2	CH	CH1	PN
mm.	Poll.-Pouces Inch.- Zoll Pulgadas									
6	1/4	● ST. 35.04.02	7/16	1/8	18,2	27	6,3	11	14	350
6	1/4	● ST. 35.04.04	7/16	1/4	21,1 2)	29	9,5	14 1)	19	350
6	1/4	● ST. 35.04.06	7/16	3/8	22,3	33	9,5	19	22	350
6	1/4	● ST. 35.04.08	7/16	1/2	22,8	38,5	13	22	27	350
8	5/16	● ST. 35.05.02	1/2	1/8	20,2 2)	27	6,3	14 1)	14	350
8	5/16	● ST. 35.05.04	1/2	1/4	21,1 2)	29	9,5	14 1)	19	350
8	5/16	● ST. 35.05.06	1/2	3/8	22,3	33	9,5	19	22	350
10	3/8	● ST. 35.06.04	9/16	1/4	21,1 2)	29	9,5	14 1)	19	350
10	3/8	● ST. 35.06.06	9/16	3/8	22,3	33	9,5	19	22	350
10	3/8	● ST. 35.06.08	9/16	1/2	22,8	38,5	13	22	27	350
12	1/2	● ST. 35.08.04	3/4	1/4	24,9	30	9,5	19	19	350
12	1/2	● ST. 35.08.06	3/4	3/8	24,9	33	9,5	19	22	350
12	1/2	● ST. 35.08.08	3/4	1/2	26,7	38,5	13	22	27	350
12	1/2	● ST. 35.08.12	3/4	3/4	26,7	44	13	27	36	350
14-15-16	5/8	● ST. 35.10.06	7/8	3/8	28,2	38,5	9,5	22	22	350
14-15-16	5/8	● ST. 35.10.08	7/8	1/2	28,2	38,5	13	22	27	350
14-15-16	5/8	● ST. 35.10.12	7/8	3/4	29,8	44	13	27	36	250
18-20	3/4	● ST. 35.12.08	1" 1/16	1/2	32,5	39,9	13	27	27	250
18-20	3/4	● ST. 35.12.12	1" 1/16	3/4	32,5	44	13	27	36	250
18-20	3/4	● ST. 35.12.16	1" 1/16	1"	36	47,5	16	33	41	250
25	1"	● ST. 35.16.12	1" 5/16	3/4	37,3	47,5	13	33	36	250
25	1"	● ST. 35.16.16	1" 5/16	1"	37,3	47,5	16	33	41	250
25	1"	● ST. 35.16.20	1" 5/16	1" 1/4	37,3	47,5	16	33	50	250
30-32	1" 1/4	● ST. 35.20.16	1" 5/8	1"	40,4	48,5	16	41	41	175
30-32	1" 1/4	● ST. 35.20.20	1" 5/8	1" 1/4	40,4	48,5	16	41	50	175
38	1" 1/2	● ST. 35.24.20	1" 7/8	1" 1/4	45,2	48,5	16	48	50	140
38	1" 1/2	● ST. 35.24.24	1" 7/8	1" 1/2	45,2	48,5	16	48	55	140

1) AISI 316L CH = 19

2) AISI 316L B = 23,5



CORPO: GOMITO MASCHIO 45° UNF 2A
CORPS: COUDE MALE 45° UNF 2A
BODY: ELBOW MALE COUPLING 45° UNF 2A
KÖRPER: WINKELEINSCHRAUBVERSCHRAUBUNG 45° UNF 2A
CUERPO: CODO MACHO 45° UNF 2A

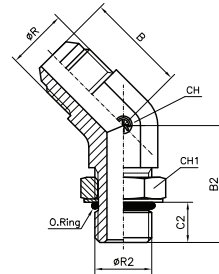

Ø TUBO-TUBE-ROHR		CODICE REFERENCE CODE BEST.-NR. REFERENCIA	Ø R-UNF JIC 37°	Ø R2 UNF	B	B2	C2	CH	CH1	PN
mm.	Poll.-Pouces Inch.- Zoll Pulgadas									
6	1/4	● ST. 36.04.04	7/16	7/16	18,3	26,7	9	11	14	350
6	1/4	● ST. 36.04.05	7/16	1/2	19,6 2)	26,7	9	14 1)	16	350
8	5/16	● ST. 36.05.05	1/2	1/2	19,6 2)	26,7	9	14 1)	16	350
10	3/8	● ST. 36.06.06	9/16	9/16	21,1 2)	29	10	14 1)	17	350
10	3/8	● ST. 36.06.08	9/16	3/4	22,3	33	11	19	22	350
12	1/2	● ST. 36.08.08	3/4	3/4	24,9	33	11	19	22	350
12	1/2	● ST. 36.08.10	3/4	7/8	24,9	38,6	12,5	22	27	350
14-15-16	5/8	● ST. 36.10.08	7/8	3/4	28,2	34,5	11	22	22	350
14-15-16	5/8	● ST. 36.10.10	7/8	7/8	28,2	38,6	12,5	22	27	350
18-20	3/4	● ST. 36.12.08	1" 1/16	3/4	32,5	35,8	11	27	22	350
18-20	3/4	● ST. 36.12.10	1" 1/16	7/8	32,5	39,8	12,5	27	27	350
18-20	3/4	● ST. 36.12.12	1" 1/16	1" 1/16	32,5	43,9	15	27	32	350
18-20	3/4	● ST. 36.12.16	1" 1/16	1" 5/16	36,1	47,2	15	33	38	350
25	1"	● ST. 36.16.12	1" 5/16	1" 1/16	37,3	43,9	15	33	32	350
25	1"	● ST. 36.16.16	1" 5/16	1" 5/16	37,3	47,2	15	33	38	350
25	1"	● ST. 36.16.20	1" 5/16	1" 5/8	39,2	48,5	15	41	50	210
30-32	1" 1/4	● ST. 36.20.20	1" 5/8	1" 5/8	40,4	48,5	15	41	50	210
38	1" 1/2	● ST. 36.24.24	1" 7/8	1" 7/8	45,2	48,5	15	48	55	140

1) AISI 316L CH = 19
2) AISI 316L B = 23,5

CORPO: GOMITO MASCHIO 45°
METRICO - ISO 6149-3
CORPS: COUDE MALE 45°
METRIQUE - ISO 6149-3
BODY: ELBOW MALE COUPLING 45°
METRIC - ISO 6149-3
KÖRPER: WINKELEINSCHRAUBVERSCHRAUBUNG 45°
METRISCH - ISO 6149-3
CUERPO: CODO MACHO 45°
METRICO - ISO 6149-3

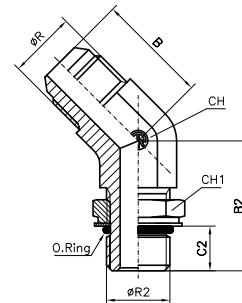

Ø TUBO-TUBE-ROHR		CODICE REFERENCE CODE BEST.-NR. REFERENCIA	Ø R-UNF JIC 37°	Ø R2 Metrico Metrique Metric Metrisch	B	B2	C2	CH	CH1	PN
mm.	Poll.- Pouces Inch.- Zoll Pulgadas									
8	5/16	● ST. 37.05.02	1/2	10x1	21,1 2)	29	8,5	14 1)	14	350
10	3/8	● ST. 37.06.04	9/16	14x1,5	21,1 2)	29	11	14 1)	19	350
10	3/8	● ST. 37.06.06	9/16	18x1,5	22,3	33	12,5	19	24	350
12	1/2	● ST. 37.08.05	3/4	16x1,5	24,9	32	11,5	19	22	350
12	1/2	● ST. 37.08.06	3/4	18x1,5	24,9	36,5	12,5	19	24	350
14-15-16	5/8	● ST. 37.10.06	7/8	18x1,5	28,2	37	12,5	22	24	350
14-15-16	5/8	● ST. 37.10.08	7/8	22x1,5	28,2	37,5	12,5	22	27	350
18-20	3/4	● ST. 37.12.08	1" 1/16	22x1,5	32,5	39	12,5	27	27	350
18-20	3/4	● ST. 37.12.14	1" 1/16	27x2	32,5	46	15,5	27	32	350
25	1"	● ST. 37.16.16	1" 5/16	33x2	37,3	45,5	15,5	33	41	280

1) AISI 316L CH = 19
2) AISI 316L B = 23,5



- CORPO: GOMITO MASCHIO 45° METRICO -
RONDELLA TENUTA O-RING
- CORPS: COUDE MALE 45° METRIQUE -
RONDELLE D'ETANCHEITE O-RING
- BODY: ELBOW MALE COUPLING 45° METRIC-
O-RING SEAL RING
- KÖRPER: WINKELEINSCHRAUBVERSCHRAUBUNG 45° METRISCH -
BEWEGLICHE UNTERLEGSCHIEBE F.O-RING
- CUERPO: CODO MACHO 45° METRICO -
ARANDELA DE RETENCION JUNTA TORICA

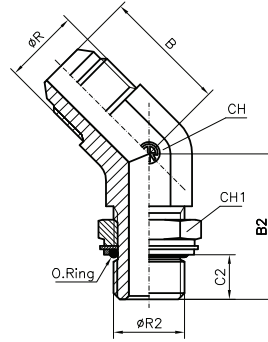

Ø TUBO-TUBE-ROHR		CODICE REFERENCE CODE BEST.-NR. REFERENCIA	Ø R-UNF JIC 37°	Ø R2 Metrico Metrique Metric Metrisch	B	B2	C2	CH	CH1	PN
mm.	Poll.- Pouces Inch.- Zoll Pulgadas									
8	5/16	● ST. 37.05.02 W	1/2	10x1	21,1 2)	29	7,5	14 1)	14	350
10	3/8	● ST. 37.06.04 W	9/16	14x1,5	21,1 2)	29	9,5	14 1)	19	350
10	3/8	● ST. 37.06.06 W	9/16	18x1,5	22,3	33	11	19	24	350
12	1/2	● ST. 37.08.05 W	3/4	16x1,5	24,9	32	10	19	22	350
12	1/2	● ST. 37.08.06 W	3/4	18x1,5	24,9	36,5	11	19	24	350
14	-	● ST. 37.10.06 W	7/8	18x1,5	28,2	37	11	22	24	350
15	-	● ST. 37.10.06 W	7/8	18x1,5	28,2	37	11	22	24	350
16	5/8	● ST. 37.10.06 W	7/8	18x1,5	28,2	37	11	22	24	350
14	-	● ST. 37.10.08 W	7/8	22x1,5	28,2	37,5	11	22	27	350
15	-	● ST. 37.10.08 W	7/8	22x1,5	28,2	37,5	11	22	27	350
16	5/8	● ST. 37.10.08 W	7/8	22x1,5	28,2	37,5	11	22	27	350
18	-	● ST. 37.12.08 W	1" 1/16	22x1,5	32,5	39	11	27	27	350
20	3/4	● ST. 37.12.08 W	1" 1/16	22x1,5	32,5	39	11	27	27	350
18	-	● ST. 37.12.14 W	1" 1/16	27x2	32,5	46	13,5	27	32	350
20	3/4	● ST. 37.12.14 W	1" 1/16	27x2	32,5	46	13,5	27	32	350
25	1"	● ST. 37.16.16 W	1" 5/16	33x2	37,3	45,5	13,5	33	41	250

1) AISI 316L CH = 19
2) AISI 316L B = 23,5

- CORPO: UNIONE GOMITO 45°
CON DADO GIREVOLE JIC
- CORPS: UNION COUDE 45°
ECROU PIVOTANT JIC
- BODY: ELBOW COUPLING 45°
WITH ROTARY NUT JIC
- KÖRPER: WINKELEINSCHRAUBVERSCHRAUBUNG 45°
MIT DREHMUTTER JIC
- CUERPO: UNION CODO 45°
CON TUERCA LOCA JIC

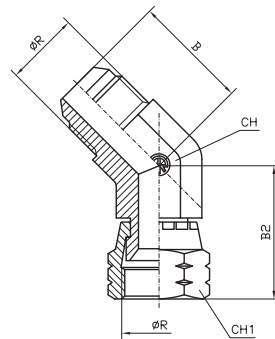

Ø TUBO-TUBE-ROHR		CODICE REFERENCE CODE BEST.-NR. REFERENCIA	Ø R-UNF JIC 37°	B	B2	CH	CH1	PN
mm.	Poll.- Pouces Inch.- Zoll Pulgadas							
6	1/4	● ST. 39.00.04	7/16	18,3	24	11	17	350
8	5/16	● ST. 39.00.05	1/2	19,6 2)	25,4	14 1)	19	350
10	3/8	● ST. 39.00.06	9/16	21,1 2)	27,5	14 1)	19	350
12	1/2	● ST. 39.00.08	3/4	24,9	32,2	19	24	350
14	-	● ST. 39.00.10	7/8	28,2	34,7	22	27	350
15	-	● ST. 39.00.10	7/8	28,2	34,7	22	27	350
16	5/8	● ST. 39.00.10	7/8	28,2	34,7	22	27	350
18	-	● ST. 39.00.12	1" 1/16	32,5	38,1	27	32	350
20	3/4	● ST. 39.00.12	1" 1/16	32,5	38,1	27	32	350
25	1"	● ST. 39.00.16	1" 5/16	37,3	43,6	33	38	350
30	-	● ST. 39.00.20	1" 5/8	40,5	51,6	41	50	210
32	1" 1/4	● ST. 39.00.20	1" 5/8	40,5	51,6	41	50	210
38	1" 1/2	● ST. 39.00.24	1" 7/8	45,2	57,2	48	60	140

1) AISI 316L CH = 19
2) AISI 316L B = 23,5



CORPO: GOMITO MASCHIO 45° NPT
CORPS: COUDE MALE 45° NPT
BODY: ELBOW MALE COUPLING 45° NPT
KÖRPER: WINKELEINSCHRAUBVERSCHRAUBUNG 45° NPT
CUERPO: CODO MACHO 45° NPT

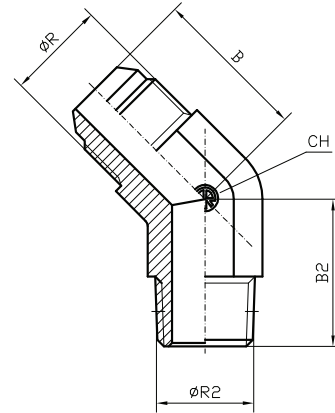

Ø TUBO-TUBE-ROHR		CODICE REFERENCE CODE BEST.-NR. REFERENCIA	Ø R-UNF JIC 37°	Ø R2 NPT	B	B2	CH	PN	
mm.	Poll.- Pouces Inch.- Zoll Pulgadas								
6	1/4	● ST. 41.04.04	7/16	1/4	20,8 2)	21,8	14 1)	350	
8	5/16	● ST. 41.05.04	1/2	1/4	20,8 2)	21,8	14 1)	350	
10	3/8	● ST. 41.06.02	9/16	1/8	21,1 2)	17	14 1)	350	
10	3/8	● ST. 41.06.04	9/16	1/4	21,1 2)	21,8	14 1)	350	
10	3/8	● ST. 41.06.06	9/16	3/8	22,1	24,1	19	350	
10	3/8	● ST. 41.06.08	9/16	1/2	22,4	29,7	22	350	
12	1/2	● ST. 41.08.04	3/4	1/4	24,9	24	19	350	
12	1/2	● ST. 41.08.06	3/4	3/8	24,9	24,1	19	350	
12	1/2	● ST. 41.08.08	3/4	1/2	25,2	29,7	22	350	
12	1/2	● ST. 41.08.12	3/4	3/4	26,5	30,5	27	350	
14	-	● ST. 41.10.06	7/8	3/8	28,2	25	22	350	
15	-	● ST. 41.10.06	7/8	3/8	28,2	25	22	350	
16	5/8	● ST. 41.10.06	7/8	3/8	28,2	25	22	350	
14	-	● ST. 41.10.08	7/8	1/2	28,2	29,7	22	350	
15	-	● ST. 41.10.08	7/8	1/2	28,2	29,7	22	250	
16	5/8	● ST. 41.10.08	7/8	1/2	28,2	29,7	22	350	
14	-	● ST. 41.10.12	7/8	3/4	29,5	30,5	27	350	
15	-	● ST. 41.10.12	7/8	3/4	29,5	30,5	27	350	
16	5/8	● ST. 41.10.12	7/8	3/4	29,5	30,5	27	350	
18	-	● ST. 41.12.08	1" 1/16	1/2	32,5	30,5	27	350	
20	3/4	● ST. 41.12.08	1" 1/16	1/2	32,5	30,5	27	350	
18	-	● ST. 41.12.12	1" 1/16	3/4	32,5	30,5	27	350	
20	3/4	● ST. 41.12.12	1" 1/16	3/4	32,5	30,5	27	350	
25	1"	● ST. 41.16.12	1" 5/16	3/4	37,3	32,5	33	280	
25	1"	● ST. 41.16.16	1" 5/16	1"	37,3	37,6	33	280	
30	-	● ST. 41.20.16	1" 5/8	1"	40,4	42,4	41	210	
32	1" 1/4	● ST. 41.20.16	1" 5/8	1"	40,4	42,4	41	210	
30	-	● ST. 41.20.20	1" 5/8	1" 1/4	40,4	42,4	41	210	
32	1" 1/4	● ST. 41.20.20	1" 5/8	1" 1/4	40,4	42,4	41	210	
38	1" 1/2	● ST. 41.24.24	1" 7/8	1" 1/2	45,2	45	48	140	

1) AISI 316L CH = 19
2) AISI 316L B = 23,5



CORPO: GOMITO MASCHIO 45° BSPT
(GAS CONICO)

CORPS: COUDE MALE 45° BSPT
(GAZ CONIQUE)

BODY: ELBOW MALE COUPLING 45° BSPT
(BSP TAPERED)

KÖRPER: WINKLEINSCHRAUBVERSCHRAUBUNG 45° BSPT
(WITHWORTH-ROHRGEWINDE KEGELIG)

CUERPO: CODO MACHO 45° BSPT
(GAS CONICO)

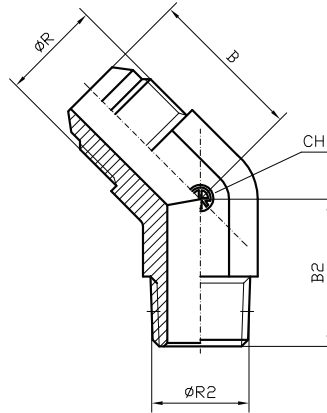

Ø TUBO-TUBE-ROHR		CODICE REFERENCE CODE BEST.-NR. REFERENCIA	Ø R-UNF JIC 37°	Ø R2 BSPT	B	B2	CH	PN	
mm.	Poll.- Pouces Inch.- Zoll Pulgadas								
6	1/4	● ST. 42.04.04	7/16	1/4	20,8 2)	21,8	14 1)	350	
8	5/16	● ST. 42.05.04	1/2	1/4	20,8 2)	21,8	14 1)	350	
10	3/8	● ST. 42.06.04	9/16	1/4	21,1 2)	21,8	14 1)	350	
10	3/8	● ST. 42.06.06	9/16	3/8	22,1	24,1	19	350	
10	3/8	● ST. 42.06.08	9/16	1/2	22,4	29,7	22	350	
12	1/2	● ST. 42.08.06	3/4	3/8	24,9	24,1	19	350	
12	1/2	● ST. 42.08.08	3/4	1/2	25,2	29,7	22	350	
14	-	● ST. 42.10.08	7/8	1/2	28,2	29,7	22	350	
15	-	● ST. 42.10.08	7/8	1/2	28,2	29,7	22	350	
16	5/8	● ST. 42.10.08	7/8	1/2	28,2	29,7	22	350	
18	-	● ST. 42.12.12	1" 1/16	3/4	32,5	30,5	27	350	
20	3/4	● ST. 42.12.12	1" 1/16	3/4	32,5	30,5	27	350	
25	1"	● ST. 42.16.16	1" 5/16	1"	37,3	37,6	33	280	
30	-	● ST. 42.20.20	1" 5/8	1" 1/4	40,4	42,4	41	210	
32	1" 1/4	● ST. 42.20.20	1" 5/8	1" 1/4	40,4	42,4	41	210	
38	1" 1/2	● ST. 42.24.24	1" 7/8	1" 1/2	45,2	45	48	140	

1) AISI 316L CH = 19
2) AISI 316L B = 23,5



CORPO: UNIONE A“T”
CORPS: UNION “T”
BODY: EQUAL TEES
KÖRPER: T-VERSCHRAUBUNG
CUERPO: TE - MACHO MACHO

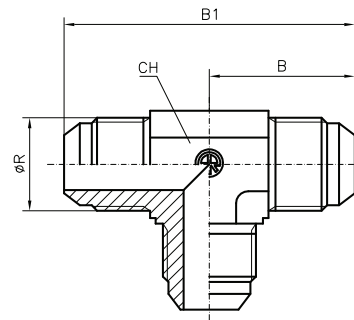

Ø TUBO-TUBE-ROHR		CODICE REFERENCE CODE BEST.-NR. REFERENCIA	Ø R-UNF JIC 37°	B	B1	CH	PN
mm.	Poll.- Pouces Inch.- Zoll Pulgadas						
6	1/4	● ST. 51.00.04	7/16	22,6	45,2	11 1)	350
8	5/16	● ST. 51.00.05	1/2	24,1	48,2	13 2)	350
10	3/8	● ST. 51.00.06	9/16	26,9	53,8	14	350
12	1/2	● ST. 51.00.08	3/4	31,8	63,6	19	350
14	-	● ST. 51.00.10	7/8	36,8	73,6	22	350
15	-	● ST. 51.00.10	7/8	36,8	73,6	22	350
16	5/8	● ST. 51.00.10	7/8	36,8	73,6	22	350
18	-	● ST. 51.00.12	1" 1/16	42,2	84,4	27	350
20	3/4	● ST. 51.00.12	1" 1/16	42,2	84,4	27	350
25	1"	● ST. 51.00.16	1" 5/16	46	92	33	280
30	-	● ST. 51.00.20	1" 5/8	52,3	104,6	41	210
32	1" 1/4	● ST. 51.00.20	1" 5/8	52,3	104,6	41	210
38	1" 1/2	● ST. 51.00.24	1" 7/8	59,2	118,4	48	140

1) - 2) AISI 316L CH = 14 B = 26,9 B1 = 53,8

CORPO: “T” DI LINEA
CON DADO GIREVOLE JIC
CORPS: “T” DE LIGNE
ECROU PIVOTANT JIC
BODY: “T” OF LINE
WITH ROTARY NUT JIC
KÖRPER: LINIEN-T
MIT DREHMUTTER JIC
CUERPO: TE MACHO FIJO
CON TUERCA LOCA CENTRAL JIC

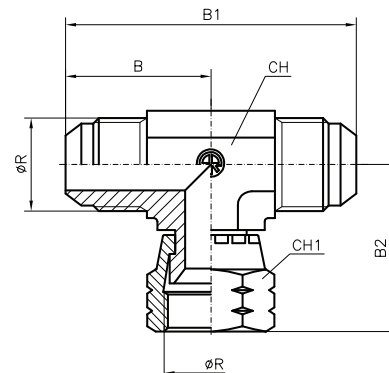

Ø TUBO-TUBE-ROHR		CODICE REFERENCE CODE BEST.-NR. REFERENCIA	Ø R-UNF JIC 37°	B	B1	B2	CH	CH1	PN
mm.	Poll.- Pouces Inch.- Zoll Pulgadas								
6	1/4	● ST. 55.00.04	7/16	22,6	45,2	25,7	11 1)	17	350
8	5/16	● ST. 55.00.05	1/2	24,1	48,2	28	13 2)	19	350
10	3/8	● ST. 55.00.06	9/16	26,9	53,8	32,5	14	19	350
12	1/2	● ST. 55.00.08	3/4	31,8	63,6	36,2	19	24	350
14	-	● ST. 55.00.10	7/8	36,8	73,6	41,2	22	27	350
15	-	● ST. 55.00.10	7/8	36,8	73,6	41,2	22	27	350
16	5/8	● ST. 55.00.10	7/8	36,8	73,6	41,2	22	27	350
18	-	● ST. 55.00.12	1" 1/16	42,2	84,4	45,8	27	32	350
20	3/4	● ST. 55.00.12	1" 1/16	42,2	84,4	45,8	27	32	350
25	1"	● ST. 55.00.16	1" 5/16	46	92	51,6	33	38	280
30	-	● ST. 55.00.20	1" 5/8	52,3	104,6	59,9	41	50	210
32	1" 1/4	● ST. 55.00.20	1" 5/8	52,3	104,6	59,9	41	50	210
38	1" 1/2	● ST. 55.00.24	1" 7/8	59,2	118,4	63,5	48	60	140

1) - 2) AISI 316L CH = 14 B = 26,9 B1 = 53,8 B2 = 28,5/30



CORPO: "T" DI DERIVAZIONE
CON DADO GIREVOLE JIC

CORPS: "T" DE DERIVATION
ECROU PIVOTANT JIC

BODY: DERIVATING "T"
WITH ROTARY NUT JIC

KÖRPER: ABLEITUNG "T"
MIT DREHMUTTER JIC

CUERPO: TE MACHO FIJO
CON TUERCA LOCA LATERAL JIC

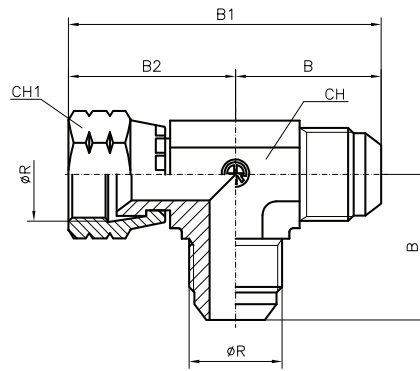

Ø TUBO-TUBE-ROHR		CODICE REFERENCE CODE BEST.-NR. REFERENCIA	Ø R-UNF JIC 37°	B	B1	B2	CH	CH1	PN
mm.	Poll.- Pouces Inch.- Zoll Pulgadas								
6	1/4	● ST. 59.00.04	7/16	22,6	48,3	25,7	11 1)	17	350
8	5/16	● ST. 59.00.05	1/2	24,1	53,6	28	13 2)	19	350
10	3/8	● ST. 59.00.06	9/16	26,9	59,4	32,5	14	19	350
12	1/2	● ST. 59.00.08	3/4	31,8	69,5	36,2	19	24	350
14	-	● ST. 59.00.10	7/8	36,8	78	41,2	22	27	350
15	-	● ST. 59.00.10	7/8	36,8	78	41,2	22	27	350
16	5/8	● ST. 59.00.10	7/8	36,8	78	41,2	22	27	350
18	-	● ST. 59.00.12	1" 1/16	42,2	89,5	45,8	27	32	350
20	3/4	● ST. 59.00.12	1" 1/16	42,2	89,5	45,8	27	32	350
25	1"	● ST. 59.00.16	1" 5/16	46	97,6	51,6	33	38	280
30	-	● ST. 59.00.20	1" 5/8	52,3	112,2	59,9	41	50	210
32	1" 1/4	● ST. 59.00.20	1" 5/8	52,3	112,2	59,9	41	50	210
38	1" 1/2	● ST. 59.00.24	1" 7/8	59,2	125	63,5	48	60	140

1) - 2) AISI 316L CH = 14 B = 26,9 B1 = 53,8 B2 = 28,5/30

CORPO: "T" MASCHIO DI LINEA UNF 2A

CORPS: "T" MALE DE LIGNE UNF 2A

BODY: "T" MALE LINE UNF 2A

KÖRPER: LINIEN EINSCHRAUß-T UNF 2A

CUERPO: TE-ORIENTABLE CENTRAL UNF 2A

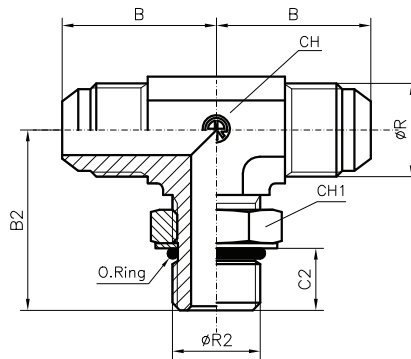

Ø TUBO-TUBE-ROHR		CODICE REFERENCE CODE BEST.-NR. REFERENCIA	Ø R-UNF JIC 37°	Ø R2 UNF	B	B2	C2	CH	CH1	PN
mm.	Poll.- Pouces Inch.- Zoll Pulgadas									
6	1/4	● ST. 60.04.04	7/16	7/16	22,6	26,2	9	11 1)	14	350
8	5/16	● ST. 60.05.05	1/2	1/2	24,1	27,7	9	13 2)	16 3)	350
10	3/8	● ST. 60.06.06	9/16	9/16	26,9	31,8	10	14	17	350
12	1/2	● ST. 60.08.08	3/4	3/4	31,8	36,8	11	19	22	350
14	-	● ST. 60.10.10	7/8	7/8	36,8	43,2	12,7	22	27	350
15	-	● ST. 60.10.10	7/8	7/8	36,8	43,2	12,7	22	27	350
16	5/8	● ST. 60.10.10	7/8	7/8	36,8	43,2	12,7	22	27	350
18	-	● ST. 60.12.12	1" 1/16	1" 1/16	42,2	49,3	15	27	32	350
20	3/4	● ST. 60.12.12	1" 1/16	1" 1/16	42,2	49,3	15	27	32	350
25	1"	● ST. 60.12.16	1" 5/16	1" 5/16	46	52,1	15	33	38	280
30	-	● ST. 60.20.20	1" 5/8	1" 5/8	52,3	57,2	15	41	50	210
32	1" 1/4	● ST. 60.20.20	1" 5/8	1" 5/8	52,3	57,2	15	41	50	210
38	1" 1/2	● ST. 60.24.24	1" 7/8	1" 7/8	59,2	60,7	15	48	55	140

1) - 2) AISI 316 L CH = 14 B = 26,9 B2 = 26,9 B2 = 30,8
3) AISI 316 L CH1 = 17



CORPO: "T" MASCHIO DI LINEA BSPP
(GAS CILINDRICO)

CORPS: "T" MALE DE LIGNE BSPP
(GAZ CYLINDRIQUE)

BODY: "T" MALE LINE BSPP
(BSP PARALLEL)

KÖRPER: LINIEN EINSCHRAUß-T BSPP
(BSP ZYLINDRISCH)

CUERPO: TE ORIENTABLE CENTRAL BSPP
(GAS CILINDRICO)

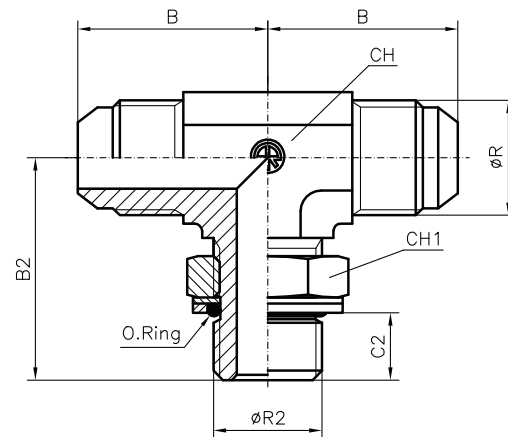

Ø TUBO-TUBE-ROHR		CODICE REFERENCE CODE BEST.-NR. REFERENCIA	Ø R-UNF JIC 37°	Ø R2 BSPP	B	B2	C2	CH	CH1	PN
mm.	Poll.- Pouces Inch.- Zoll Pulgadas									
6	1/4	● ST. 61.04.02	7/16	1/8	22,6	26	6,3	11 1)	14	350
6	1/4	● ST. 61.04.04	7/16	1/4	26,7	31,8	9,5	14	19	350
6	1/4	● ST. 61.04.06	7/16	3/8	28,5	37	9,5	19	22	350
6	1/4	● ST. 61.04.08	7/16	1/2	30,7	43	13	22	27	350
8	5/16	● ST. 61.05.02	1/2	1/8	24,1	26	6,3	13 2)	14	350
8	5/16	● ST. 61.05.04	1/2	1/4	26,7	31,8	9,5	14	19	350
8	5/16	● ST. 61.05.06	1/2	3/8	28,7	36,8	9,5	19	22	350
10	3/8	● ST. 61.06.04	9/16	1/4	26,9	32,5	9,5	14	19	350
10	3/8	● ST. 61.06.06	9/16	3/8	29	37,5	9,5	19	22	350
10	3/8	● ST. 61.06.08	9/16	1/2	31,1	43	13	22	27	350
12	1/2	● ST. 61.08.04	3/4	1/4	31,8	33,5	9,5	19	19	350
12	1/2	● ST. 61.08.06	3/4	3/8	31,8	37,5	9,5	19	22	350
12	1/2	● ST. 61.08.08	3/4	1/2	33,7	43	13	22	27	350
12	1/2	● ST. 61.08.12	3/4	3/4	36	49,5	13	27	36	350
14	-	● ST. 61.10.06	7/8	3/8	36,8	39,1	9,5	22	22	350
15	-	● ST. 61.10.06	7/8	3/8	36,8	39,1	9,5	22	22	350
16	5/8	● ST. 61.10.06	7/8	3/8	36,8	39,1	9,5	22	22	350
14	-	● ST. 61.10.08	7/8	1/2	36,8	43	13	22	27	350
15	-	● ST. 61.10.08	7/8	1/2	36,8	43	13	22	27	350
16	5/8	● ST. 61.10.08	7/8	1/2	36,8	43	13	22	27	350
14	-	● ST. 61.10.12	7/8	3/4	38,9	49,5	13	27	36	350
15	-	● ST. 61.10.12	7/8	3/4	38,9	49,5	13	27	36	350
16	5/8	● ST. 61.10.12	7/8	3/4	38,9	49,5	13	27	36	350
18	-	● ST. 61.12.08	1" 1/16	1/2	42,2	49,5	13	27	27	250
20	3/4	● ST. 61.12.08	1" 1/16	1/2	42,2	49,5	13	27	27	250
18	-	● ST. 61.12.12	1" 1/16	3/4	42,2	49,5	13	27	36	250
20	3/4	● ST. 61.12.12	1" 1/16	3/4	42,2	49,5	13	27	36	250
18	-	● ST. 61.12.16	1" 1/16	1"	44,8	52	16	33	41	250
20	3/4	● ST. 61.12.16	1" 1/16	1"	44,8	52	16	33	41	250
25	1"	● ST. 61.16.12	1" 5/16	3/4	46	52	13	33	36	250
25	1"	● ST. 61.16.16	1" 5/16	1"	46	52	16	33	41	250
25	1"	● ST. 61.16.20	1" 5/16	1" 1/4	51	57	16	41	50	250
30	-	● ST. 61.20.16	1" 5/8	1"	52,3	57	16	41	41	175
32	1" 1/4	● ST. 61.20.16	1" 5/8	1"	52,3	57	16	41	41	175
30	-	● ST. 61.20.20	1" 5/8	1" 1/4	52,3	57	16	41	50	175
32	1" 1/4	● ST. 61.20.20	1" 5/8	1" 1/4	52,3	57	16	41	50	175
38	1" 1/2	● ST. 61.24.20	1" 7/8	1" 1/4	59,2	60,5	16	48	50	140
38	1" 1/2	● ST. 61.24.24	1" 7/8	1" 1/2	59,2	60,5	16	48	55	140

1)-2) AISI 316 L CH = 14 B = 26,9 B2 = 28,5



CORPO: "T" MASCHIO DI LINEA METRICO - ISO 6149-3
 CORPS: "T" MALE DE LIGNE METRIQUE - ISO 6149-3
 BODY: "T" MALE LINE METRIC - ISO 6149-3
 KÖRPER: LINIEN EINSCHRAUß-T METRISCH - ISO 6149-3
 CUERPO: TE ORIENTABLE CENTRAL METRICO - ISO 6149-3

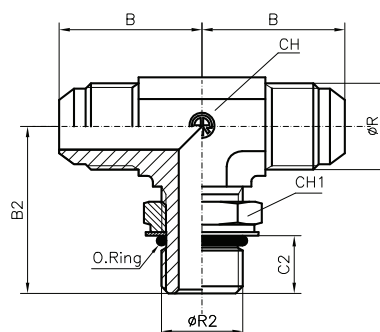

Ø TUBO-TUBE-ROHR		CODICE REFERENCE CODE BEST.-NR. REFERENCIA	Ø R-UNF JIC 37°	Ø R2 Metrico Metrique Metric Metrisch	B	B2	C2	CH	CH1	PN
mm.	Poll.- Pouces Inch.- Zoll Pulgadas									
6	1/4	● ST. 62.04.02	7/16	10x1	22,6	27	8,5	11 1)	14	350
8	5/16	● ST. 62.05.03	1/2	12x1,5	24,1	29	11	13 2)	17	350
10	3/8	● ST. 62.06.04	9/16	14x1,5	26,9	34	11	14	19	350
12	1/2	● ST. 62.08.05	3/4	16x1,5	31,8	36	11,5	19	22	350
12	1/2	● ST. 62.08.06	3/4	18x1,5	31,8	38	12,5	19	24	350
14	-	● ST. 62.10.06	7/8	18x1,5	36,8	41,5	12,5	22	24	350
15	-	● ST. 62.10.06	7/8	18x1,5	36,8	41,5	12,5	22	24	350
16	5/8	● ST. 62.10.06	7/8	18x1,5	36,8	41,5	12,5	22	24	350
14	-	● ST. 62.10.08	7/8	22x1,5	36,8	42,5	12,5	22	27	350
15	-	● ST. 62.10.08	7/8	22x1,5	36,8	42,5	12,5	22	27	350
16	5/8	● ST. 62.10.08	7/8	22x1,5	36,8	42,5	12,5	22	27	350
18	-	● ST. 62.12.08	1" 1/16	22x1,5	42,2	45	12,5	27	27	350
20	3/4	● ST. 62.12.08	1" 1/16	22x1,5	42,2	45	12,5	27	27	350
18	-	● ST. 62.12.14	1" 1/16	27x2	42,2	51	15,5	27	32	350
20	3/4	● ST. 62.12.14	1" 1/16	27x2	42,2	51	15,5	27	32	350
25	1"	● ST. 62.16.14	1" 5/16	27x2	46	53	15,5	33	32	280

1) - 2) AISI 316L CH = 14 B = 26,9 B2 = 31,5/34

CORPO: "T" MASCHIO DI LINEA METRICO - RONDELLA TENUTA O-RING
 CORPS: "T" MALE DE LIGNE METRIQUE - RONDELLE D'ETANCHEITE O-RING
 BODY: "T" MALE LINE METRIC - O-RING SEAL RING
 KÖRPER: LINIEN EINSCHRAUß-T METRISCH - BEWEGLICHE UNTERLEGSCHIBE F.O-RING
 CUERPO: TE ORIENTABLE CENTRAL METRICO - ARANDELA DE RETENCION JUNTA TORICA

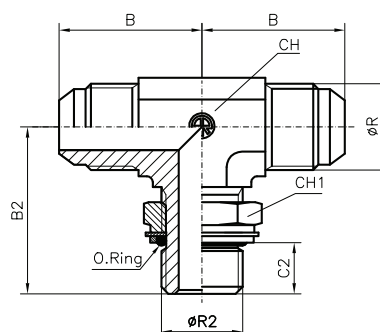

Ø TUBO-TUBE-ROHR		CODICE REFERENCE CODE BEST.-NR. REFERENCIA	Ø R-UNF JIC 37°	Ø R2 Metrico Metrique Metric Metrisch	B	B2	C2	CH	CH1	PN
mm.	Poll.- Pouces Inch.- Zoll Pulgadas									
6	1/4	● ST. 62.04.02 W	7/16	10x1	22,6	27	7,5	11 1)	14	350
8	5/16	● ST. 62.05.03 W	1/2	12x1,5	24,1	29	9,5	13 2)	17	350
10	3/8	● ST. 62.06.04 W	9/16	14x1,5	26,9	34	9,5	14	19	350
12	1/2	● ST. 62.08.05 W	3/4	16x1,5	31,8	36	10	19	22	350
12	1/2	● ST. 62.08.06 W	3/4	18x1,5	31,8	38	11	19	24	350
14	-	● ST. 62.10.06 W	7/8	18x1,5	36,8	41,5	11	22	24	350
15	-	● ST. 62.10.06 W	7/8	18x1,5	36,8	41,5	11	22	24	350
16	5/8	● ST. 62.10.06 W	7/8	18x1,5	36,8	41,5	11	22	24	350
14	-	● ST. 62.10.08 W	7/8	22x1,5	36,8	42,5	11	22	27	350
15	-	● ST. 62.10.08 W	7/8	22x1,5	36,8	42,5	11	22	27	350
16	5/8	● ST. 62.10.08 W	7/8	22x1,5	36,8	42,5	11	22	27	350
18	-	● ST. 62.12.08 W	1" 1/16	22x1,5	42,2	45	11	27	27	350
20	3/4	● ST. 62.12.08 W	1" 1/16	22x1,5	42,2	45	11	27	27	350
18	-	● ST. 62.12.14 W	1" 1/16	27x2	42,2	51	13,5	27	32	350
20	3/4	● ST. 62.12.14 W	1" 1/16	27x2	42,2	51	13,5	27	32	350
25	1"	● ST. 62.16.14 W	1" 5/16	27x2	46	53	13,5	33	32	250

1) - 2) AISI 316 L CH = 14 B = 26,9 B2 = 31,5/34



CORPO: "T" MASCHIO DI DERIVAZIONE BSPP
(GAS CILINDRICO)
CORPS: "T" MALE DE DERIVATION BSPP
(GAZ CYLINDRIQUE)
BODY: DERIVATING "T" BSPP
(BSP PARALLEL)
KÖRPER: ABLEITUNG "T" BSPP
(BSP ZYLINDRISCH)
CUERPO: TE ORIENTABLE LATERAL BSPP
(GAS CILINDRICO)

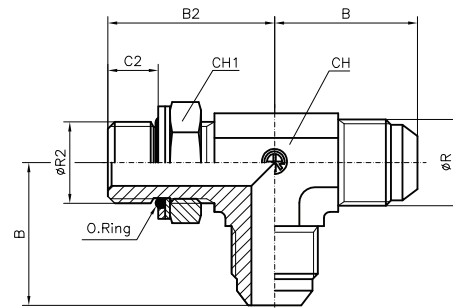

Ø TUBO-TUBE-ROHR		CODICE REFERENCE CODE BEST.-NR. REFERENCIA	Ø R-UNF JIC 37°	Ø R2 BSPP	B*	B2*	C2	CH	CH1	PN
mm.	Poll.- Pouces Inch.- Zoll Pulgadas									
6	1/4	● ST. 63.04.02	7/16	1/8	22,6	26	6,3	11 1)	14	350
6	1/4	● ST. 63.04.04	7/16	1/4	26,7	31,8	9,5	14	19	350
6	1/4	● ST. 63.04.06	7/16	3/8	28,5	37	9,5	19	22	350
6	1/4	● ST. 63.04.08	7/16	1/2	26,9	43	13	22	27	350
8	5/16	● ST. 63.05.02	1/2	1/8	24,1	26	6,3	13 2)	14	350
8	5/16	● ST. 63.05.04	1/2	1/4	26,7	31,8	9,5	14	19	350
8	5/16	● ST. 63.05.06	1/2	3/8	28,7	36,8	9,5	19	22	350
10	3/8	● ST. 63.06.04	9/16	1/4	26,9	32,5	9,5	14	19	350
10	3/8	● ST. 63.06.06	9/16	3/8	29	37,5	9,5	19	22	350
10	3/8	● ST. 63.06.08	9/16	1/2	31,1	43	13	22	27	350
12	1/2	● ST. 63.08.04	3/4	1/4	31,8	33,5	9,5	19	19	350
12	1/2	● ST. 63.08.06	3/4	3/8	31,8	37,5	9,5	19	22	350
12	1/2	● ST. 63.08.08	3/4	1/2	33,7	43	13	22	27	350
12	1/2	● ST. 63.08.12	3/4	3/4	36	49,5	13	27	36	350
14-15-16	5/8	● ST. 63.10.06	7/8	3/8	36,8	39,1	9,5	22	22	350
14-15-16	5/8	● ST. 63.10.08	7/8	1/2	36,8	43	13	22	27	350
14-15-16	5/8	● ST. 63.10.12	7/8	3/4	38,9	49,5	13	27	36	350
18-20	3/4	● ST. 63.12.08	1" 1/16	1/2	42,2	45,2	13	27	27	250
18-20	3/4	● ST. 63.12.12	1" 1/16	3/4	42,2	49,5	13	27	36	250
18-20	3/4	● ST. 63.12.16	1" 1/16	1"	44,8	52	16	33	41	250
25	1"	● ST. 63.16.12	1" 5/16	3/4	46	52	13	33	36	250
25	1"	● ST. 63.16.16	1" 5/16	1"	46	52	16	33	41	250
25	1"	● ST. 63.16.20	1" 5/16	1" 1/4	51	57	16	41	50	250
30-32	1" 1/4	● ST. 63.20.16	1" 5/8	1"	52,3	57	16	41	41	175
30-32	1" 1/4	● ST. 63.20.20	1" 5/8	1" 1/4	52,3	57	16	41	50	175
38	1" 1/2	● ST. 63.24.20	1" 7/8	1" 1/4	59,2	60,5	16	48	50	140
38	1" 1/2	● ST. 63.24.24	1" 7/8	1" 1/2	59,2	60,5	16	48	55	140

1) - 2) AISI 316L CH = 14

*Quote non valide per AISI 316L



CORPO: "T" MASCHIO DI DERIVAZIONE
METRICO - ISO 6149-3

CORPS: "T" MALE DE DERIVATION
METRIQUE - ISO 6149-3

BODY: DERIVATING "T"
METRIC - ISO 6149-3

KÖRPER: ABLEITUNG "T"
METRISCH - ISO 6149-3

CUERPO: TE ORIENTABLE LATERAL
METRICO - ISO 6149-3

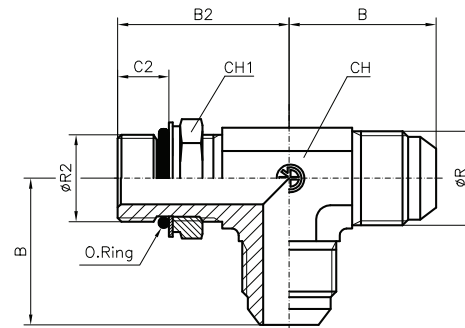

Ø TUBO-TUBE-ROHR		CODICE REFERENCE CODE BEST.-NR. REFERENCIA	Ø R-UNF JIC 37°	Ø R2 Metrico Metric Metric	B	B2	C2	CH	CH1	PN
mm.	Poll.- Pouces Inch.- Zoll Pulgadas									
6	1/4	● ST. 64.04.02	7/16	10x1	22,6	27	8,5	11 1)	14	350
8	5/16	● ST. 64.05.03	1/2	12x1,5	24,1	29	11	13 2)	17	350
10	3/8	● ST. 64.06.04	9/16	14x1,5	26,9	34	11	14	19	350
12	1/2	● ST. 64.08.05	3/4	16x1,5	31,8	36	11,5	19	22	350
12	1/2	● ST. 64.08.06	3/4	18x1,5	31,8	38	12,5	19	24	350
14-15-16	5/8	● ST. 64.10.06	7/8	18x1,5	36,8	41,5	12,5	22	24	350
14-15-16	5/8	● ST. 64.10.08	7/8	22x1,5	36,8	42,5	12,5	22	27	350
18-20	3/4	● ST. 64.12.08	1" 1/16	22x1,5	42,2	45	12,5	27	27	350
18-20	3/4	● ST. 64.12.14	1" 1/16	27x2	42,2	51	15,5	27	32	350
25	1"	● ST. 64.16.14	1" 5/16	27x2	46	53	15,5	33	32	280

1) - 2) AISI 316L CH = 14 B = 26,9 B2 = 31,5/34

CORPO: "T" MASCHIO DI DERIVAZIONE METRICO -
RONDELLA TENUTA O-RING

CORPS: "T" MALE DE DERIVATION METRIQUE -
RONDELLE D'ETANCHEITE O-RING

BODY: DERIVATING "T" METRIC -
O-RING SEAL RING

KÖRPER: ABLEITUNG "T" METRISCH -
BEWEGLICHE UNTERLEGSSCHEIBE F.O-RING

CUERPO: TE ORIENTABLE LATERAL METRICO -
ARANDELA DE RETENCION JUNTA TORICA

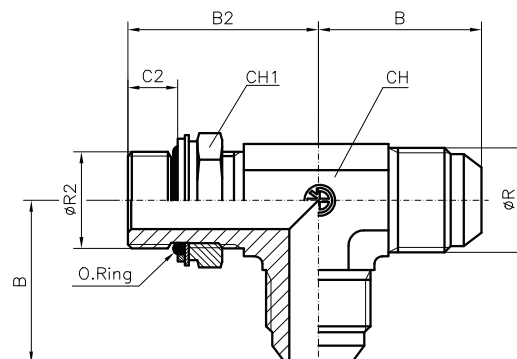

Ø TUBO-TUBE-ROHR		CODICE REFERENCE CODE BEST.-NR. REFERENCIA	Ø R-UNF JIC 37°	Ø R2 Metrico Metric Metric	B	B2	C2	CH	CH1	PN
mm.	Poll.- Pouces Inch.- Zoll Pulgadas									
6	1/4	● ST. 64.04.02 W	7/16	10x1	22,6	27	7,5	11 1)	14	350
8	5/16	● ST. 64.05.03 W	1/2	12x1,5	24,1	29	9,5	13 2)	17	350
10	3/8	● ST. 64.06.04 W	9/16	14x1,5	26,9	34	9,5	14	19	350
12	1/2	● ST. 64.08.05 W	3/4	16x1,5	31,8	36	10	19	22	350
12	1/2	● ST. 64.08.06 W	3/4	18x1,5	31,8	38	11	19	24	350
14-15-16	5/8	● ST. 64.10.06 W	7/8	18x1,5	36,8	41,5	11	22	24	350
14-15-16	5/8	● ST. 64.10.08 W	7/8	22x1,5	36,8	42,5	11	22	27	350
18-20	3/4	● ST. 64.12.08 W	1" 1/16	22x1,5	42,2	45	11	27	27	350
18-20	3/4	● ST. 64.12.14 W	1" 1/16	27x2	42,2	51	13,5	27	32	350
25	1"	● ST. 64.16.14 W	1" 5/16	27x2	46	53	13,5	33	32	250

1) - 2) AISI 316L CH = 14 B = 26,9 B2 = 31,5/34



CORPO: "T" MASCHIO DI DERIVAZIONE UNF 2A
CORPS: "T" MALE DE DERIVATION UNF 2A
BODY: DERIVATING "T" UNF 2A
KÖRPER: ABLEITUNG "T" UNF 2A
CUERPO: TE ORIENTABLE LATERAL UNF 2A

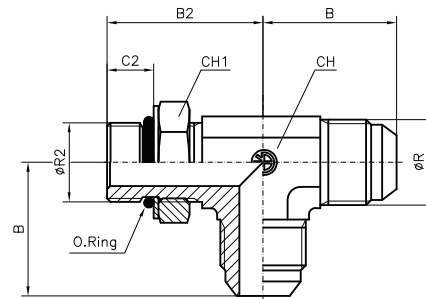

Ø TUBO-TUBE-ROHR		CODICE REFERENCE CODE BEST.-NR. REFERENCIA	Ø R-UNF JIC 37°	Ø R2 UNF	B	B2	C2	CH	CH1	PN
mm.	Poll.- Pouces Inch.- Zoll Pulgadas									
6	1/4	● ST. 65.04.04	7/16	7/16	22,6	26,2	9	11 1)	14	350
8	5/16	● ST. 65.05.05	1/2	1/2	24,1	27,7	9	13 2)	16 3)	350
10	3/8	● ST. 65.06.06	9/16	9/16	26,9	31,8	10	14	17	350
12	1/2	● ST. 65.08.08	3/4	3/4	31,8	36,8	11	19	22	350
14	-	● ST. 65.10.10	7/8	7/8	36,8	43,2	12,7	22	27	350
15	-	● ST. 65.10.10	7/8	7/8	36,8	43,2	12,7	22	27	350
16	5/8	● ST. 65.10.10	7/8	7/8	36,8	43,2	12,7	22	27	350
18	-	● ST. 65.12.12	1" 1/16	1" 1/16	42,2	49,3	15	27	32	350
20	3/4	● ST. 65.12.12	1" 1/16	1" 1/16	42,2	49,3	15	27	32	350
25	1"	● ST. 65.16.16	1" 5/16	1" 5/16	46	52,1	15	33	38	280
30	-	● ST. 65.20.20	1" 5/8	1" 5/8	52,3	57,2	15	41	50	210
32	1" 1/4	● ST. 65.20.20	1" 5/8	1" 5/8	52,3	57,2	15	41	50	210
38	1" 1/2	● ST. 65.24.24	1" 7/8	1" 7/8	59,2	60,7	15	48	55	140

1) - 2) AISI 316L CH = 14 B = 26,9 B2 = 30,8 3) AISI 316L CH1 = 17

CORPO: "T" MASCHIO DI LINEA NPT
CORPS: "T" MALE DE LIGNE NPT
BODY: "T" MALE LINE NPT
KÖRPER: LINIEN EINSCHRAUB-T NPT
CUERPO: TE MACHO CÓNICO NPT

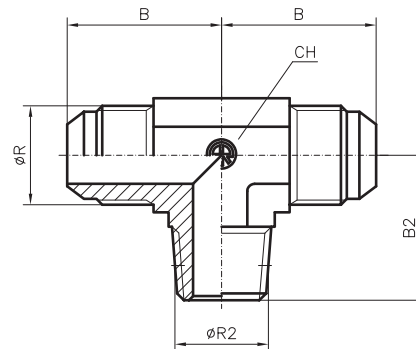

Ø TUBO-TUBE-ROHR		CODICE REFERENCE CODE BEST.-NR. REFERENCIA	Ø R-UNF JIC 37°	Ø R2 NPT	B	B2	CH	PN
mm.	Poll.- Pouces Inch.- Zoll Pulgadas							
6	1/4	● ST. 66.04.02	7/16	1/8	22,6	19,8	11 1)	350
6	1/4	● ST. 66.04.04	7/16	1/4	26,9	27,7	14	350
8	5/16	● ST. 66.05.02	1/2	1/8	24,1	19,8	13 2)	350
10	3/8	● ST. 66.06.04	9/16	1/4	26,9	27,7	14	350
10	3/8	● ST. 66.06.06	9/16	3/8	29	31	19	350
12	1/2	● ST. 66.08.06	3/4	3/8	31,8	31	19	350
12	1/2	● ST. 66.08.08	3/4	1/2	33,7	37,3	22	350
14	-	● ST. 66.10.08	7/8	1/2	36,8	37,3	22	350
15	-	● ST. 66.10.08	7/8	1/2	36,8	37,3	22	350
16	5/8	● ST. 66.10.08	7/8	1/2	36,8	37,3	22	350
18	-	● ST. 66.12.12	1" 1/16	3/4	42,2	40,4	27	350
20	3/4	● ST. 66.12.12	1" 1/16	3/4	42,2	40,4	27	350
25	1"	● ST. 66.16.16	1" 5/16	1"	46	50	33	280
30	-	● ST. 66.20.20	1" 5/8	1" 1/4	52,3	59,6	41	210
32	1" 1/4	● ST. 66.20.20	1" 5/8	1" 1/4	52,3	59,6	41	210
38	1" 1/2	● ST. 66.24.24	1" 7/8	1" 1/2	59,2	67,1	48	140

1) - 2) AISI 316L CH = 14 B = 26,9



CORPO: "T" MASCHIO DI LINEA BSPT
(GAS CONICO)

CORPS: "T" MALE DE LIGNE BSPT
(GAZ CONIQUE)

BODY: "T" MALE LINE BSPT
(BSP TAPERED)

KÖRPER: LINIEN EINSCHRAUB-T BSPT
(WITHWORTROHRGEWINDE KEGELIG)

CUERPO: TE MACHO CÓNICO BSPT
(GAS CONICO)

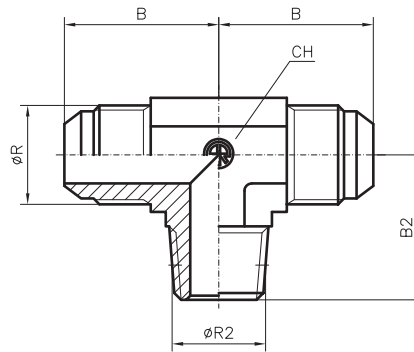

Ø TUBO-TUBE-ROHR		CODICE REFERENCE CODE BEST.-NR. REFERENCIA	Ø R-UNF JIC 37°	Ø R2 BSPT	B	B2	CH	PN
mm.	Poll.- Pouces Inch.- Zoll Pulgadas							
6	1/4	● ST. 67.04.02	7/16	1/8	22,6	19,8	11 1)	350
8	5/16	● ST. 67.05.02	1/2	1/8	24,1	19,8	13 2)	350
10	3/8	● ST. 67.06.04	9/16	1/4	26,9	27,7	14	350
12	1/2	● ST. 67.08.06	3/4	3/8	31,8	31	19	350
14	-	● ST. 67.10.08	7/8	1/2	36,8	37,3	22	350
15	-	● ST. 67.10.08	7/8	1/2	36,8	37,3	22	350
16	5/8	● ST. 67.10.08	7/8	1/2	36,8	37,3	22	350
18	-	● ST. 67.12.12	1" 1/16	3/4	42,2	40,4	27	350
20	3/4	● ST. 67.12.12	1" 1/16	3/4	42,2	40,4	27	350
25	1"	● ST. 67.16.16	1" 5/16	1"	46	50	33	280

1) - 2) AISI 316L CH = 14 B = 26,9

CORPO: T" MASCHIO DI DERIVAZIONE NPT

CORPS: "T" MALE DE DERIVATION NPT

BODY: DERIVATING "T" NPT

KÖRPER: ABLEITUNG "T" NPT

CUERPO: TE MACHO DERIVACION NPT

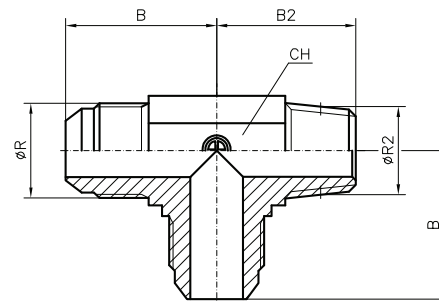

Ø TUBO-TUBE-ROHR		CODICE REFERENCE CODE BEST.-NR. REFERENCIA	Ø R-UNF JIC 37°	Ø R2 NPT	B	B2	CH	PN
mm.	Poll.- Pouces Inch.- Zoll Pulgadas							
6	1/4	● ST. 68.04.02	7/16	1/8	22,6	19,8	11 1)	350
6	1/4	● ST. 68.04.04	7/16	1/4	26,9	27,7	14	350
8	5/16	● ST. 68.05.02	1/2	1/8	24,1	19,8	13 2)	350
10	3/8	● ST. 68.06.04	9/16	1/4	26,9	27,7	14	350
10	3/8	● ST. 68.06.06	9/16	3/8	29	31	19	350
12	1/2	● ST. 68.08.06	3/4	3/8	31,8	31	19	350
12	1/2	● ST. 68.08.08	3/4	1/2	33,7	37,3	22	350
14	-	● ST. 68.10.08	7/8	1/2	36,8	37,3	22	350
15	-	● ST. 68.10.08	7/8	1/2	36,8	37,3	22	350
16	5/8	● ST. 68.10.08	7/8	1/2	36,8	37,3	22	350
18	-	● ST. 68.12.12	1" 1/16	3/4	42,2	40,4	27	350
20	3/4	● ST. 68.12.12	1" 1/16	3/4	42,2	40,4	27	350
25	1"	● ST. 68.16.16	1" 5/16	1"	46	50	33	280
30	-	● ST. 68.20.20	1" 5/8	1" 1/4	52,3	59,6	41	210
32	1" 1/4	● ST. 68.20.20	1" 5/8	1" 1/4	52,3	59,6	41	210
38	1" 1/2	● ST. 68.24.24	1" 7/8	1" 1/2	59,2	67,1	48	140

1) - 2) AISI 316L CH = 14 B = 26,9



CORPO: "T" MASCHIO DI DERIVAZIONE BSPT
(GAS CONICO)

CORPS: "T" MALE DE DERIVATION BSPT
(GAZ CONIQUE)

BODY: DERIVATING "T" BSPT
(BSP TAPERED)

KÖRPER: ABLEITUNG-T BSPT
(WITHWORTH-ROHRGEWINDE KEGELIG)

CUERPO: TE MACHO DERIVACION BSPT
(GAS CONICO)

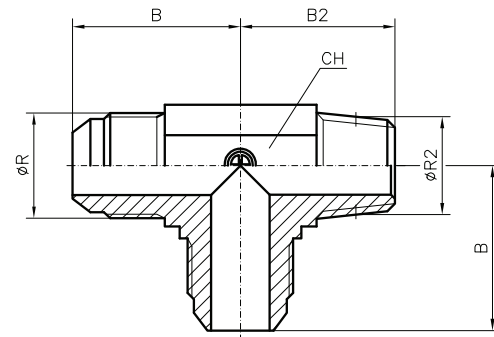

Ø TUBO-TUBE-ROHR		CODICE REFERENCE CODE BEST.-NR. REFERENCIA	Ø R-UNF JIC 37°	Ø R2 BSPT	B	B2	CH	PN	
mm.	Poll.- Pouces Inch.- Zoll Pulgadas								
6	1/4	● ST. 69.04.02	7/16	1/8	22,6	19,8	11 1)	350	
8	5/16	● ST. 69.05.02	1/2	1/8	24,1	19,8	13 2)	350	
10	3/8	● ST. 69.06.04	9/16	1/4	26,9	27,7	14	350	
12	1/2	● ST. 69.08.06	3/4	3/8	31,8	31	19	350	
14	-	● ST. 69.10.08	7/8	1/2	36,8	37,3	22	350	
15	-	● ST. 69.10.08	7/8	1/2	36,8	37,3	22	350	
16	5/8	● ST. 69.10.08	7/8	1/2	36,8	37,3	22	350	
18	-	● ST. 69.12.12	1" 1/16	3/4	42,2	40,4	27	350	
20	3/4	● ST. 69.12.12	1" 1/16	3/4	42,2	40,4	27	350	
25	1"	● ST. 69.16.16	1" 5/16	1"	46	50	33	280	

1) - 2) AISI 316L CH = 14 B = 26,9

CORPO: "T" DI LINEA FEMMINA NPT

CORPS: "T" MALE DE LIGNE FEMELLE NPT

BODY: "T" MALE LINE FEMALE NPT

KÖRPER: LINIEN EINSCHRAUß-T MUTTERSETTING NPT

CUERPO: TE HEMBRA CENTRAL NPT

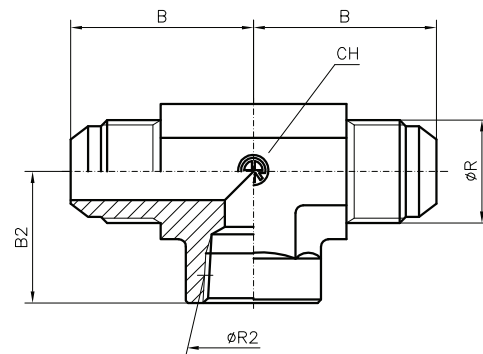

Ø TUBO-TUBE-ROHR		CODICE REFERENCE CODE BEST.-NR. REFERENCIA	Ø R-UNF JIC 37°	Ø R2 NPT	B	B2	CH	PN	
mm.	Poll.- Pouces Inch.- Zoll Pulgadas								
6	1/4	● ST. 71.04.02	7/16	1/8	27,4	16,8	14	350	
6	1/4	● ST. 71.04.04	7/16	1/4	31	22,4	19	350	
8	5/16	● ST. 71.05.02	1/2	1/8	27,4	16,8	14	350	
10	3/8	● ST. 71.06.04	9/16	1/4	31,2	22,4	19	350	
12	1/2	● ST. 71.08.06	3/4	3/8	36,1	25,9	22	350	
14	-	● ST. 71.10.08	7/8	1/2	41,7	31,2	27	350	
15	-	● ST. 71.10.08	7/8	1/2	41,7	31,2	27	350	
16	5/8	● ST. 71.10.08	7/8	1/2	41,7	31,2	27	350	
18	-	● ST. 71.12.12	1" 1/16	3/4	48	34,5	33	350	
20	3/4	● ST. 71.12.12	1" 1/16	3/4	48	34,5	33	350	
25	1"	● ST. 71.16.16	1" 5/16	1"	55,1	41,4	41	250	
30	-	● ST. 71.20.20	1" 5/8	1" 1/4	59,2	43,2	48	210	
32	1" 1/4	● ST. 71.20.20	1" 5/8	1" 1/4	59,2	43,2	48	210	



CORPO: "T" DI DERIVAZIONE FEMMINA NPT
 CORPS: "T" MALE DE DERIVATION FEMELLE NPT
 BODY: DERIVATING "T" FEMALE NPT
 KÖRPER: ABLEITUNG "T" MUTTERSETTING NPT
 CUERPO: "T" DERIVACION HEMBRA NPT

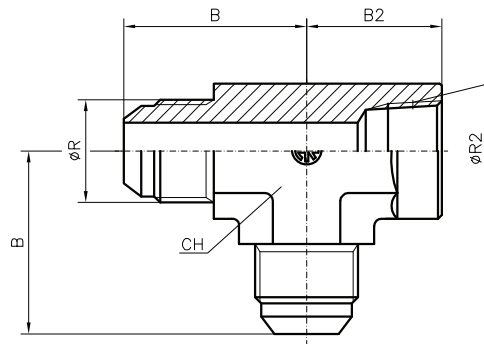

Ø TUBO-TUBE-ROHR		CODICE REFERENCE CODE BEST.-NR. REFERENCIA	Ø R-UNF JIC 37°	Ø R2 NPT	B	B2	CH	PN	
mm.	Poll.- Pouces Inch.- Zoll Pulgadas								
6	1/4	● ST. 73.04.02	7/16	1/8	27,4	16,8	14	350	
6	1/4	● ST. 73.04.04	7/16	1/4	31	22,4	19	350	
8	5/16	● ST. 73.05.02	1/2	1/8	27,4	16,8	14	350	
10	3/8	● ST. 73.06.04	9/16	1/4	31,2	22,4	19	350	
12	1/2	● ST. 73.08.06	3/4	3/8	36,1	25,9	22	350	
14	-	● ST. 73.10.08	7/8	1/2	41,7	31,2	27	350	
15	-	● ST. 73.10.08	7/8	1/2	41,7	31,2	27	350	
16	5/8	● ST. 73.10.08	7/8	1/2	41,7	31,2	27	350	
18	-	● ST. 73.12.12	1" 1/16	3/4	48	34,5	33	350	
20	3/4	● ST. 73.12.12	1" 1/16	3/4	48	34,5	33	350	
25	1"	● ST. 73.16.16	1" 5/16	1"	55,1	41,4	41	250	
30	-	● ST. 73.20.20	1" 5/8	1" 1/4	59,2	43,2	48	210	
32	1" 1/4	● ST. 73.20.20	1" 5/8	1" 1/4	59,2	43,2	48	210	



UTENSILI PER SVASARE: PUNZONI E SERRATUBI

Questi attrezzi vengono usati sulla morsa per la svasatura dei tubi di acciaio da Ø 6 a Ø 38.
Dal tubo Ø 20 occorre l'impiego del punzone presvasatore.

- Sistemare il tubo nel serratubo, in modo che sia allineato alla faccia superiore di questo.
- Procedere alla svasatura battendo col martello sul punzone.
- Capacità: tubi in millimetri da Ø 6x1 a Ø 38x4 mm.
tubi in pollici da 1/4 a 1" 1/2 Ø est.

OUTILS A EVASER: POINÇONS ET BLOQUE-TUBES

Ces outils sont utilisés sur l'étau, pour évasement des tubes en acier de Ø 6 à Ø 38.

Du tube Ø 20, il faut employer le poinçon pré-évasement.

- Arranger le tube dans le bloque-tube de manière que il soit aligné à la face supérieure de ce là.
- Procéder à l'évasement en battant avec le marteau sur le poinçon.
- Capacité: tubes en millimètres de Ø 6x1 à Ø 38 mm.
tubes en pouces Ø 1/4 à Ø 1" 1/2.

FLARING TOOLS: PUNCHES AND PIPE TONGS

These tools are used on the vice for flaring dia. 6 to dia. 38 steel pipes.

From dia. 20 pipes upwards it is necessary to use a preflaring punch.

- Put the pipe in the pipe tongs so that it is flush with their upper surface.
- Start flaring by striking the punch with a hammer.
- Capacities: pipes in millimetres from Ø 6x1 to Ø 38x4 mm.
pipes in inches from 1/4 to 1" 1/2 outside Ø.

BÖRDELWERKZEUGE: BÖRDELDORN UND BÖRDELBLOCK

Diese Werkzeuge werden an dem Schraubstock zur Bördelung von Stahlrohren Ø 6 bis Ø 38 verwendet.

Ab Rohrgröße Ø 20 bedarf es eines Vorbördeldorns.

- Das Rohr in den Bördelblock einsetzen, so daß es auf gleicher Höhe mit dessem obrem Teil ist.
- Durch Schlagen mit einem Hammer auf den Bördeldorn die Bördelung vornehmen
- Anwendungsbereich: Rohre Ø 6x1 bis 38x4 mm.
Rohre von 1/4 bis 1" 1/2 Aussen Ø

UTILES PARA ABOCARDAR: PUNZONES Y MORDAZAS

Estas herramientas son utilizadas para el abocardado de los tubos de acero de Ø 6 a Ø 38.

Para el tubo Ø 20 se necesita el punzon preabocardador.

- Colocar el tubo entre las mordazas de forma que resulte alineado con la parte superior de ellas.
- Proceder al abocardado golpeando con el martillo el punzon.
- Capacidad: tubos en milímetros de 6x1 a 38x4 mm.
tubos en pulgadas de 1/4 a 1" 1/2 Ø ext.

TN 352



TN 353



TN 354 - TN 355



Ø E TUBO Ø E TUBE Ø E TUBE Ø A ROHR mm.	PUNZONEPRESVASATORE POINÇON PREEVASEMENT PRE-FLARING PUNCH VORBÖRDELDORN PUNZON PREABOCARDADOR	PUNZONE POINÇON PUNCH BÖRDELDORN PUNZON	SERRATUBO BLOQUE TUBE TUBE TONGS BÖRDELBLOCK MORZADA	Ø E TUBO Ø E TUBE Ø E TUBE Ø A ROHR mm.	PUNZONE PRESVASATORE POINÇON PREEVASEMENT PRE-FLARING PUNCH VORBÖRDELDORN PUNZON PREABOCARDADOR	PUNZONE POINÇON PUNCH BÖRDELDORN PUNZON	SERRATUBO BLOQUE TUBE TUBE TONGS BÖRDELBLOCK MORZADA
6	-	TN 353-08	TN 354-06	1/4	-	TN 353-08	TN 355-04
8	-	TN 353-08	TN 354-08	5/16	-	TN 353-08	TN 354-08
10	-	TN 353-08	TN 354-10	3/8	-	TN 353-08	TN 355-06
12	-	TN 353-14	TN 354-12	1/2	-	TN 353-14	TN 355-08
14	-	TN 353-14	TN 354-14	-	-	-	-
15	-	TN 353-14	TN 354-15	-	-	-	-
16	-	TN 353-14	TN 354-16	5/8	-	TN 353-14	TN 355-10
18	-	TN 353-18	TN 354-18	-	-	-	-
20	TN 352-1	TN 353-18	TN 354-20	3/4	TN 352-1	TN 353-18	TN 355-12
25	TN 352-1	TN 353-22	TN 354-25	1"	TN 352-1	TN 353-22	TN 355-16
30	TN 352-1	TN 353-32	TN 354-30	-	TN 352-1	-	-
32	TN 352-1	TN 353-32	TN 354-32	1" 1/4	TN 352-1	TN 353-32	TN 355-20
38	TN 352-1	TN 353-38	TN 354-38	1" 1/2	TN 352-1	TN 353-38	TN 355-24



RACCORDI PER ALTA PRESSIONE FILETTATURA GAS

Il sistema di filettatura di questo tipo di raccordi viene impiegato dalla BRITISH STANDARD PIPE (FILETTATURA GAS WHITWORTH B.S.P.).

L'unione ai tubi della condotta verrà realizzata mediante saldatura in acciaio, autogena o ad arco. Dopo la saldatura dei pezzi, il raffreddamento deve essere graduale.

I tubi normalmente utilizzati sono in acciaio trafilato a freddo senza saldatura per condutture idrauliche.

Nella seguente tabella vengono riportate le sezioni delle condutture per ciascun diametro di filettatura.

RACCORDS POUR HAUTE PRESSION FILETAGE GAZ

Le système de filetage de ce type de raccord est utilisé par BRITISH STANDARD PIPE (FILETAGE GAS WHITWORTH B.S.P.).

L'accouplement des tubes de la conduite se fera par soudure en acier, autogène et à arc.

Après soudage des pièces, le refroidissement doit être progressif.

Les tubes utilisés normalement sont en acier tréfilé à froid sans soudures pour conduites hydrauliques.

Dans les tables suivantes figurent les sections des conduites pour chaque diamètre de filetage.

FITTINGS FOR HIGH PRESSURE GAS THREAD

The thread system in this type of fitting is used by BRITISH STANDARD PIPE (B.S.P. WHITWORTH GAS THREAD).

The pipe/duct joint is effected through autogenous or arc welding with steel. After the pieces have been welded, cooling must be gradual.

Pipes generally used are made out of weldless cold-drawn steel for hydraulic ducts.

The following table shows the duct cross-section each thread diameter.

HOCHDRUCKVERSCHRAUBUNGEN MIT GAS-GEWINDE

Das Gewindesystem dieser Verschraubungen wird von BRITISH STANDARD PIPE (WHITWORTH GAS-GEWINDE B.S.P.) verwendet. Die Verbindung mit den Leitungsrohren erfolgt mit Stahl-, autogen-oder mit Bogenschweißverfahren.

Nach dem Verschweißen der Stücke hat eine stufenweise Kühlung zu erfolgen.

Die in der Regel verwendeten Rohre bestehen aus kaltgezogenem Stahl ohne Schweißstellen für Wasserleitungen.

In der folgenden Tabelle sind die Querschnitte der Leitungen für jeden Gewindedurchmesser aufgeführt.

RACORERIA PARA ALTA PRESIÓN ROSCA GAS

El sistema de rosca de este tipo de racores es el empleado por la BRITISH STANDARD PIPE (ROSCA GAS WHITWORTH B.S.P.).

La unión a los tubos de conducción se realizará soldándolos con acero, a la autógena o al arco; una vez realizada la soldadura no se deberá enfriar bruscamente.

Los tubos que normalmente se utilizarán serán los de conducciones hidráulicas de acero estirado en frío y sin soldadura.

En la tabla adjunta se anotan las secciones de conducción para cada diámetro de rosca:

FILETTATURA DEL RACCORDO FILETAGE DU RACCORD FITTING THREAD ANSCHLUSSGEWINDE ROSCA DEL RACOR	SEZIONE MINIMA CONDUTTURA (cm ²) SECTION MINIMUM CONDUITE (cm ²) MINIMUM DUCT CROSS SECTION (cm ²) MIN. QUERSCHNITT D. LEITUNG (cm ²) SECCIÓN MÍNIMA DE CONDUCCIÓN (cm ²)	a 1,5 m/s	PORTATA MASSIMA I/M	a 4 m/s
		à 1,5 m/s	DEBIT MAXIMUM I/M	à 4 m/s
		at 1,5 m/s	MAXIMUM CAPACITY I/M	at 4 m/s
		bei 1,5 m/s	MAX. FÖRDERLEISTUNG I/min	bei 4 m/s
		a 1,5 m/seg.	CAUDAL MAXIMO I/M DE PASO	a 4 m/seg.
1/4"	0,28		2,52	6,72
3/8"	0,63		5,70	15,10
1/2"	1,13		10,20	27,10
3/4"	1,76		15,80	42,20
1"	3,14		28,20	75,30
1" 1/4	5,30		47,70	127,00
1" 1/2	8,55		77,00	205,00



ADATTATORI - BSPP
ADAPTATEURS - BSPP
ADAPTORS - BSPP
ADAPTER - BSPP
ADAPTADORES - BSPP

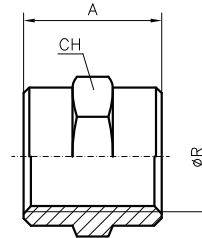

Ø TUBO-TUBE-ROHR		CODICE REFERENCE CODE BEST.-NR. REFERENCIA	Ø R-BSPP femmina femelle female mutterseiting hembra	A	CH	PN	
mm	Poll.- Pouces Inch.- Zoll Pulgadas						
-	-	● 34. 00.02.02	1/8	18	17	350	
-	-	● 34. 00.04.04	1/4	26	19	350	-
-	-	● 34. 00.06.06	3/8	27	24	315	
-	-	● 34. 00.08.08	1/2	31	30	210	
-	-	● 34. 00.12.12	3/4	35	36	210	
-	-	● 34. 00.16.16	1"	41	41	120	
-	-	● 34. 00.20.20	1" 1/4	45	55	105	
-	-	● 34. 00.24.24	1" 1/2	45	60	105	

ADATTATORI RIDOTTI - BSPT
ADAPTATEURS DE REDUCTION - BSPT
REDUCED ADAPTORS - BSPT
ADAPTER REDUZIERUNG - BSPT
ADAPTADORES REDUCIDO - BSPT

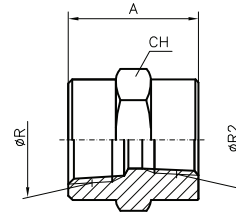

Ø TUBO-TUBE-ROHR		CODICE REFERENCE CODE BEST.-NR. REFERENCIA	Ø R-BSPT femmina femelle female mutterseiting hembra	Ø R2-BSPT femmina femelle female mutterseiting hembra	A	CH	PN	
mm	Poll.- Pouces Inch.- Zoll Pulgadas							
-	-	● 34. 01.04.02	1/4	1/8	24,2	19	420	
-	-	● 34. 01.06.02	3/8	1/8	24,2	22	420	
-	-	● 34. 01.06.04	3/8	1/4	28,7	22	420	
-	-	● 34. 01.08.04	1/2	1/4	34,8	30	350	
-	-	● 34. 01.08.06	1/2	3/8	34,8	30	350	
-	-	● 34. 01.12.04	3/4	1/4	35,6	36	280	
-	-	● 34. 01.12.08	3/4	1/2	38,9	36	280	

ADATTATORI - BSPT
ADAPTATEURS - BSPT
ADAPTORS - BSPT
ADAPTER - BSPT
ADAPTADORES - BSPT

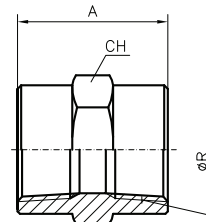

Ø TUBO-TUBE-ROHR		CODICE REFERENCE CODE BEST.-NR. REFERENCIA	Ø R-BSPT femmina femelle female mutterseiting hembra	A	CH	PN	
mm	Poll.-Pouces Inch.- Zoll Pulgadas						
-	-	● 34. 02.02.02	1/8	19	16 1)	420	
-	-	● 34. 02.04.04	1/4	28,7	19	420	
-	-	● 34. 02.06.06	3/8	28,7	22	420	
-	-	● 34. 02.08.08	1/2	38,1	30	350	
-	-	● 34. 02.12.12	3/4	38,9	36	280	
-	-	● 34. 02.16.16	1"	48	41	210	
-	-	● 34. 02.20.20	1" 1/4	49	50	175	
-	-	● 34. 02.24.24	1" 1/2	49	60	140	

1) AISI 316L CH = 17



ADATTATORI RIDOTTI NPT
ADAPTATEURS DE REDUCTION NPT
REDUCED ADAPTORS NPT
ADAPTER REDUZIERUNG NPT
ADAPTADORES REDUCIDO NPT

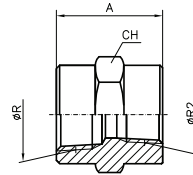

Ø TUBO-TUBE-ROHR		CODICE REFERENCE CODE BEST.-NR. REFERENCIA	Ø R-NPT femmina femelle female mutterseiting hembra	Ø R2-NPT femmina femelle female mutterseiting hembra	A	CH	PN
mm.	Poll.- Pouces Inch.- Zoll Pulgadas						
-	-	● 34. 03.04.02	1/4	1/8	24,2	19	420
-	-	● 34. 03.06.02	3/8	1/8	24,2	22	420
-	-	● 34. 03.06.04	3/8	1/4	28,7	22	420
-	-	● 34. 03.08.04	1/2	1/4	34,8	30	350
-	-	● 34. 03.08.06	1/2	3/8	34,8	30	350
-	-	● 34. 03.12.04	3/4	1/4	35,6	36	280
-	-	● 34. 03.12.08	3/4	1/2	38,9	36	280

ADATTATORI - NPT
ADAPTATEURS - NPT
ADAPTORS - NPT
ADAPTER - NPT
ADAPTADORES - NPT

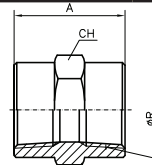

Ø TUBO-TUBE-ROHR		CODICE REFERENCE CODE BEST.-NR. REFERENCIA	Ø R-NPT femmina femelle female mutterseiting hembra	A	CH	PN
mm.	Poll.- Pouces Inch.- Zoll Pulgadas					
-	-	● 34. 04.02.02	1/8	19	16 1)	420
-	-	● 34. 04.04.04	1/4	28,7	19	420
-	-	● 34. 04.06.06	3/8	28,7	22	420
-	-	● 34. 04.08.08	1/2	38,1	30	350
-	-	● 34. 04.12.12	3/4	38,9	36	280
-	-	● 34. 04.16.16	1"	48	41	210
-	-	● 34. 04.20.20	1" 1/4	49	50	175
-	-	● 34. 04.24.24	1" 1/2	49	60	140

1) AISI 316L CH = 17

ADATTATORE DIRITTO FEMMINA / FEMMINA DADO GIREVOLE
ADAPTATEURS FEMELLE / FEMELLE ECROU PIVOTANT
ADAPTORS - FEMALE / FEMALE WITH ROTARY NUT
ADAPTER MUTTERSETTING MIT DREHMUTTER
ADAPTADORES HEMBRA / HEMBRA CON TUERCA LOCA

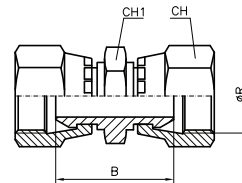

Ø TUBO-TUBE-ROHR		CODICE REFERENCE CODE BEST.-NR. REFERENCIA	Ø R BSPP	B	CH	CH1	PN
mm.	Poll.- Pouces Inch.- Zoll Pulgadas						
-	-	● 34. 11.02.02	1/8	31	14	14	350
-	-	● 34. 11.04.04	1/4	31	19	19	350
-	-	● 34. 11.06.06	3/8	35	22	22	350
-	-	● 34. 11.08.08	1/2	39,5	27	27	200
-	-	● 34. 11.10.10	5/8	42,5	28 1)	30	200
-	-	● 34. 11.12.12	3/4	43,5	32	32	200
-	-	● 34. 11.16.16	1"	47,5	38 2)	41	120
-	-	● 34. 11.20.20	1" 1/4	56,5	50	50	105
-	-	● 34. 11.24.24	1" 1/2	66,5	55	55	105

1) AISI 316L CH = 30 2) AISI 316L CH = 41

ADATTATORE DIRITTO RIDOTTO FEMMINA / FEMMINA DADO GIREVOLE
ADAPTATEURS DE REDUCTION FEMELLE / FEMELLE ECROU PIVOTANT
REDUCED ADAPTORS - FEMALE / FEMALE WITH ROTARY NUT
ADAPTER REDUZIERUNG MUTTERSETTING MIT DREHMUTTER
ADAPTADORES REDUCIDO HEMBRA / HEMBRA CON TUERCA LOCA

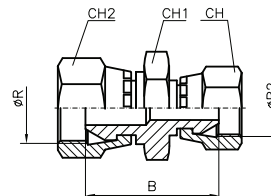

Ø TUBO-TUBE-ROHR		CODICE REFERENCE CODE BEST.-NR. REFERENCIA	Ø R BSPP	Ø R2 BSPP	B	CH	CH1	CH2	PN
mm.	Poll.- Pouces Inch.- Zoll Pulgadas								
-	-	● 34. 12.06.04	3/8	1/4	33	22	22	19	350
-	-	● 34. 12.08.04	1/2	1/4	35,5	27	27	19	200
-	-	● 34. 12.08.06	1/2	3/8	37,5	27	27	22	200
-	-	● 34. 12.12.08	3/4	1/2	42	32	32	27	200



NIPPLO MASCHIO RIDOTTO
FILETTATURA NPT/NPT
UNION DOUBLE DE REDUCTION NPT/NPT
REDUCED MALE NIPPLE
NPT/NPT THREAD
GEWINDE ZAPFEN REDUZIERUNG
NPT/NPT GEWINDE
ENLACE MACHO - REDUCIDO
RECTO ROSCA NPT/NPT

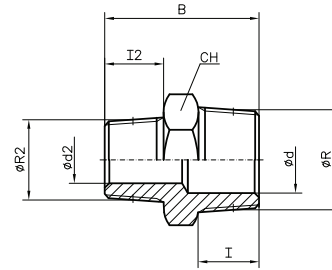

Ø TUBO-TUBE-ROHR		CODICE REFERENCE CODE BEST.-NR. REFERENCIA	Ø R NPT	Ø R2 NPT	Ø d	Ø d2	I	I2	B	CH	PN
mm.	Poll.- Pouces Inch.- Zoll Pulgadas										
-	-	● 34. 57.04.02	1/4	1/8	7	4,5	14,2	9,7	32,3	16 1)	420
-	-	● 34. 57.06.02	3/8	1/8	10	4,5	14,2	9,7	32,3	19	420
-	-	● 34. 57.06.04	3/8	1/4	10	7	14,2	14,2	36,8	19	420
-	-	● 34. 57.08.04	1/2	1/4	13,5	7	19	14,2	43,2	22	420
-	-	● 34. 57.08.06	1/2	3/8	13,5	10	19	14,2	43,2	22	420
-	-	● 34. 57.12.04	3/4	1/4	18	7	19	14,2	45	30	420
-	-	● 34. 57.12.08	3/4	1/2	18	13,5	19	19	49,8	30	420
-	-	● 34. 57.16.12	1"	3/4	23	18	23,9	19	54,5	36	420
-	-	● 34. 57.20.16	1" 1/4	1"	31	23	24,6	23,9	62,3	46	350

1) AISI 316L CH = 17

NIPPLO MASCHIO DI ESTREMITÀ DIRITTO
FILETTATURA NPT/NPT
UNION SIMPLE NPT/NPT
MALE NIPPLE STUD COUPLING
NPT/NPT THREAD
GEWINDE ZAPFEN
NPT/NPT GEWINDE
ENLACE MACHO - RECTO
ROSCA NPT/NPT

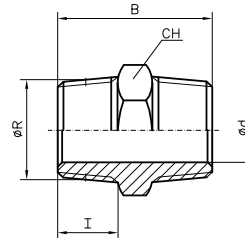

Ø TUBO-TUBE-ROHR		CODICE REFERENCE CODE BEST.-NR. REFERENCIA	Ø R NPT	Ø d	B	I	CH	PN
mm.	Poll.- Pouces Inch.- Zoll Pulgadas							
-	-	● 34. 58.02.02	1/8	4,5	26,9	9,7	11 1)	420
-	-	● 34. 58.04.04	1/4	7	36,8	14,2	16 2)	420
-	-	● 34. 58.06.06	3/8	10	36,8	14,2	19	420
-	-	● 34. 58.08.08	1/2	13,5	48	19	22	420
-	-	● 34. 58.12.12	3/4	18	49,8	19	30	420
-	-	● 34. 58.16.16	1"	23	59,4	23,9	36	420
-	-	● 34. 58.20.20	1" 1/4	31	63	24,6	46	350
-	-	● 34. 58.24.24	1" 1/2	38	66,3	25,4	50	210
-	-	● 34. 58.32.32	2"	49	71,6	26,2	65	210

1) AISI 316L CH = 12 2) AISI 316L CH = 17

NIPPLO MASCHIO RIDOTTO
FILETTATURA GAS CONICA BSPT
UNION DOUBLE DE REDUCTION BSPT
REDUCED MALE NIPPLE - STRAIGHT COUPLING
BSPT TAPARED THREAD
GEWINDE ZAPFEN REDUZIERUNG
BSPT KONISCH GEWINDE
ENLACE MACHO - REDUCIDO RECTO ROSCA
GAS CONICA BSPT

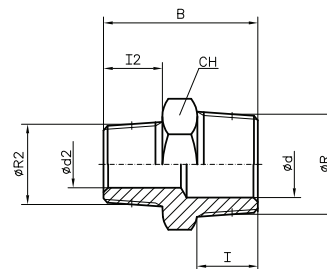

Ø TUBO-TUBE-ROHR		CODICE REFERENCE CODE BEST.-NR. REFERENCIA	Ø R BSPT	Ø R2 BSPT	Ø d	Ø d2	I	I2	B	CH	PN
mm.	Poll.- Pouces Inch.- Zoll Pulgadas										
-	-	● 34. 59.04.02	1/4	1/8	7	4,5	13	10	32,3	14	420
-	-	● 34. 59.06.02	3/8	1/8	10	4,5	13	10	33,8	17	420
-	-	● 34. 59.06.04	3/8	1/4	10	7	13	13	36,8	17	420
-	-	● 34. 59.08.04	1/2	1/4	13,5	7	16	13	43,2	22	420
-	-	● 34. 59.08.06	1/2	3/8	13,5	10	16	13	43,2	22	420
-	-	● 34. 59.12.04	3/4	1/4	18	7	18	13	46,8	27	420
-	-	● 34. 59.12.08	3/4	1/2	18	13,5	18	16	49,8	27	420
-	-	● 34. 59.16.12	1"	3/4	23	18	20	18	54,5	36	420
-	-	● 34. 59.20.16	1" 1/4	1"	31	23	21	20	62	46	350



NIPPO MASCHIO DI ESTREMITÀ DIRITTO
FILETTATURA GAS CONICA BSPT
UNION SIMPLE BSPT
MALE NIPPLE STUD COUPLING BSPT THREAD
GEWINDEZAPFEN BSPT GEWINDE
ENLACE MACHO - RECTO ROSCA BSPT

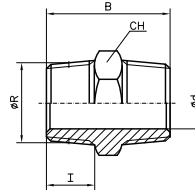

Ø TUBO-TUBE-ROHR		CODICE REFERENCE CODE BEST.-NR. REFERENCIA	Ø R BSPT	Ø d	B	I	CH	PN	
mm.	Poll.- Pouces Inch.- Zoll Pulgadas								
-	-	● 34. 60.02.02	1/8	4,5	26,9	10	11 1)	420	
-	-	● 34. 60.04.04	1/4	7	36,8	13	14	420	
-	-	● 34. 60.06.06	3/8	10	36,8	13	17	420	
-	-	● 34. 60.08.08	1/2	13,5	48	16	22	420	
-	-	● 34. 60.12.12	3/4	18	49,8	18	27	420	
-	-	● 34. 60.16.16	1"	23	59,4	20	36	420	
-	-	● 34. 60.20.20	1" 1/4	31	63	21	46	350	
-	-	● 34. 60.24.24	1" 1/2	38	66,3	22	50	210	
-	-	● 34. 60.32.32	2"	49	71,6	25	65	210	

1) AISI 316L CH = 12

NIPPO MASCHIO RIDOTTO
FILETTATURA GAS CILINDRICA BSPP/NPT
UNION DOUBLE DE REDUCTION BSPP/NPT
REDUCED MALE NIPPLE STRAIGHT
COUPLING BSPP PARALLEL THREAD/NPT
GEWINDEZAPFEN REDUZIERUNG BSPP
GEWINDE ZYLINDRISCH/NPT
ENLACE MACHO - REDUCIDO RECTO
ROSCA GAS CILINDRICA BSPP/NPT

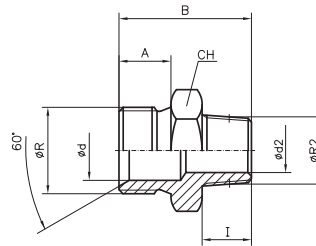

Ø TUBO-TUBE-ROHR		CODICE REFERENCE CODE BEST.-NR. REFERENCIA	Ø R BSPP	Ø R2 NPT	Ø d	Ø d2	B	A	I	CH	PN
mm.	Poll.- Pouces Inch.- Zoll Pulgadas										
-	-	● 34. 64.02.04	1/8	1/4	4	4	32,2	10	14,2	17	350
-	-	● 34. 64.04.02	1/4	1/8	6	4	28,7	11	9,7	17	350
-	-	● 34. 64.04.06	1/4	3/8	6	6	34,7	11	14,2	19	350
-	-	● 34. 64.06.04	3/8	1/4	8	6	36,7	13	14,2	19	350
-	-	● 34. 64.06.08	3/8	1/2	8	8	42	13	19	24	350
-	-	● 34. 64.08.06	1/2	3/8	11	8	38,2	14	14,2	24	200
-	-	● 34. 64.08.12	1/2	3/4	11	11	43	14	19	32	200
-	-	● 34. 64.12.08	3/4	1/2	17	11	46	17	19	32	200
-	-	● 34. 64.12.16	3/4	1"	17	17	52,9	17	23,9	41	200
-	-	● 34. 64.16.12	1"	3/4	23	17	51	20	19	41	120
-	-	● 34. 64.16.20	1"	1" 1/4	23	31	56,6	20	24,6	46	120
-	-	● 34. 64.20.24	1" 1/4	1" 1/2	30	38	60	21	25,4	50	105

NIPPO MASCHIO DI ESTREMITÀ DIRITTO
FILETTATURA GAS CILINDRICA BSPP/NPT
UNION SIMPLE BSPP/NPT
MALE NIPPLE STUD COUPLING
BSPP PARALLEL/NPT
GEWINDEZAPFEN BSPP GEWINDE
ZYLINDRISCH/NPT
ENLACE MACHO - RECTO
ROSCA GAS CILINDRICA BSPP/NPT

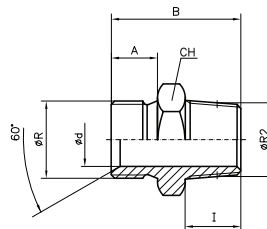

Ø TUBO-TUBE-ROHR		CODICE REFERENCE CODE BEST.-NR. REFERENCIA	Ø R BSPP	Ø R2 NPT	Ø d	B	A	I	CH	PN	
mm.	Poll.- Pouces Inch.- Zoll Pulgadas										
-	-	● 34. 65.02.02	1/8	1/8	4	25,7	10	9,7	12	350	
-	-	● 34. 65.04.04	1/4	1/4	6	33,2	11	14,2	17	350	
-	-	● 34. 65.06.06	3/8	3/8	8	36,7	13	14,2	19	350	
-	-	● 34. 65.08.08	1/2	1/2	11	43	14	19	24	200	
-	-	● 34. 65.12.12	3/4	3/4	17	46	17	19	32	200	
-	-	● 34. 65.16.16	1"	1"	23	55,9	20	23,9	41	120	
-	-	● 34. 65.20.20	1" 1/4	1" 1/4	31	58,6	20	24,6	50	105	
-	-	● 34. 65.24.24	1" 1/2	1" 1/2	38	63,4	22	25,4	55	105	
-	-	● 34. 65.32.32	2"	2"	49	68,2	25	26,2	65	70	



NIPPLIO MASCHIO RIDOTTO
FILETTATURA GAS CILINDRICA - GAS CONICA
UNION DOUBLE DE REDUCTION
BSPP/BSPT
REDUCED MALE NIPPLE STRAIGHT COUPLING
BSPP PARALLEL - BSP TAPERED THREAD
GEWINDEZAPFEN REDUZIERUNG BSPP
GEWINDE ZYLINDRISCH BSP KONISCH
ENLACE MACHO - REDUCIDO RECTO
ROSCA GAS CILINDRICA - GAS CONICA

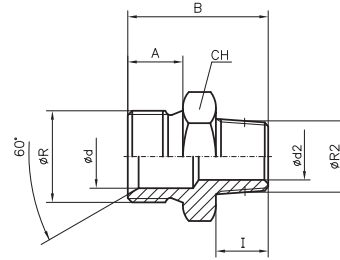

Ø TUBO-TUBE-ROHR		CODICE REFERENCE CODE BEST.-NR. REFERENCIA	Ø R BSPP	Ø R2 BSPT	Ø d	Ø d2	B	A	I	CH	PN
mm.	Poll.- Pouces Inch.- Zoll Pulgadas										
-	-	● 34. 66.02.04	1/8	1/4	4	4	31	10	13	17	350
-	-	● 34. 66.04.02	1/4	1/8	6	4	29	11	10	17	350
-	-	● 34. 66.04.06	1/4	3/8	6	6	33,5	11	13	19	350
-	-	● 34. 66.06.04	3/8	1/4	8	6	35,5	13	13	19	350
-	-	● 34. 66.06.08	3/8	1/2	8	8	39	13	16	24	200
-	-	● 34. 66.08.06	1/2	3/8	11	8	37	14	13	24	200
-	-	● 34. 66.08.12	1/2	3/4	11	14	42	14	18	27	200
-	-	● 34. 66.10.08	5/8	1/2	14	11	41	15	16	27	200
-	-	● 34. 66.10.12	5/8	3/4	14	14	43	15	18	32	200
-	-	● 34. 66.12.08	3/4	1/2	17	11	43	17	16	32	200
-	-	● 34. 66.12.16	3/4	1"	17	17	49	17	20	41	120
-	-	● 34. 66.16.12	1"	3/4	23	17	50	20	18	41	120
-	-	● 34. 66.16.20	1"	1" 1/4	23	31	53	20	21	46	120
-	-	● 34. 66.20.24	1" 1/4	1" 1/2	30	35	56	20	22	50	105

NIPPLIO MASCHIO RIDOTTO - INTERMEDIO DIRITTO
FILETTATURA GAS CILINDRICA BSP
UNION DOUBLE
DE REDUCTION BSPP
REDUCED MALE NIPPLE STRAIGHT COUPLING
BSP PARALLEL THREAD
GEWINDEZAPFEN REDUZIERUNG BSP
GEWINDE ZYLINDRISCH
ENLACE MACHO - REDUCIDO RECTO
ROSCA GAS CILINDRICA BSP

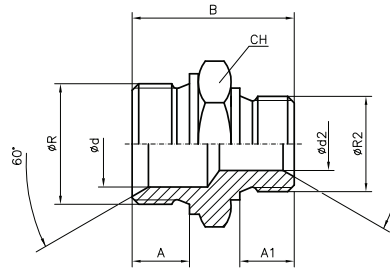

Ø TUBO-TUBE-ROHR		CODICE REFERENCE CODE BEST.-NR. REFERENCIA	Ø R BSPP	Ø R2 BSPP	Ø d	Ø d2	B	A	A1	CH	PN
mm.	Poll.- Pouces Inch.- Zoll Pulgadas										
-	-	● 34. 67.04.02	1/4	1/8	6	4	28,5	11	8	19	350
-	-	● 34. 67.06.02	3/8	1/8	8	4	30,5	12	8	22	350
-	-	● 34. 67.06.04	3/8	1/4	8	6	33,5	12	11	22	350
-	-	● 34. 67.08.02	1/2	1/8	11	4	36,5	14	8	27	200
-	-	● 34. 67.08.04	1/2	1/4	11	6	36,5	14	11	27	200
-	-	● 34. 67.08.06	1/2	3/8	11	8	38	14	12	27	200
-	-	● 34. 67.10.04	5/8	1/4	14	6	39	16	11	30	200
-	-	● 34. 67.10.06	5/8	3/8	14	8	40	16	12	30	200
-	-	● 34. 67.10.08	5/8	1/2	14	11	42	16	14	30	200
-	-	● 34. 67.12.04	3/4	1/4	17	6	40	16	11	32	200
-	-	● 34. 67.12.06	3/4	3/8	17	8	41	16	12	32	200
-	-	● 34. 67.12.08	3/4	1/2	17	11	43,5	16	14	32	200
-	-	● 34. 67.12.10	3/4	5/8	17	14	45,5	16	16	32	200
-	-	● 34. 67.16.04	1"	1/4	23	6	44,5	19	11	41	120
-	-	● 34. 67.16.06	1"	3/8	23	8	45,5	19	12	41	120
-	-	● 34. 67.16.08	1"	1/2	23	11	47,5	19	14	41	120
-	-	● 34. 67.16.10	1"	5/8	23	14	49,5	19	16	41	120
-	-	● 34. 67.16.12	1"	3/4	23	17	49,5	19	16	41	120
-	-	● 34. 67.20.08	1" 1/4	1/2	30	11	51,5	20	14	50	105
-	-	● 34. 67.20.10	1" 1/4	5/8	30	14	53,5	20	16	50	105
-	-	● 34. 67.20.12	1" 1/4	3/4	30	17	53,5	20	16	50	105
-	-	● 34. 67.20.16	1" 1/4	1"	30	23	56,5	20	19	50	105
-	-	● 34. 67.24.08	1" 1/2	1/2	35	11	53,5	22	14	55	105
-	-	● 34. 67.24.12	1" 1/2	3/4	35	17	55,5	22	16	55	105
-	-	● 34. 67.24.16	1" 1/2	1"	35	23	58,5	22	19	55	105
-	-	● 34. 67.24.20	1" 1/2	1" 1/4	35	30	59,5	22	20	55	105
-	-	● 34. 67.32.16	2"	1"	46	23	62	25	19	70	70
-	-	● 34. 67.32.20	2"	1" 1/4	46	30	63	25	20	70	70
-	-	● 34. 67.32.24	2"	1" 1/2	46	35	65	25	22	70	70



NIPPLO MASCHIO - DI ESTREMITÀ DIRITTO
FILETTATURA GAS CILINDRICA - GAS CONICA

UNION SIMPLE
BSPP/BSPT

MALE NIPPLE STUD COUPLING
BSP PARALLEL - BSP TAPERED THREAD

GEWINDEZAPFEN BSP
ZYLINDRISCH BSP KONISCH

ENLACE MACHO - RECTO ROSCA
GAS CILINDRICA - GAS CONICA

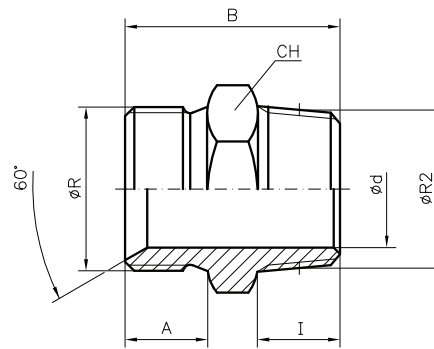

Ø TUBO-TUBE-ROHR		CODICE REFERENCE CODE BEST.-NR. REFERENCIA	Ø R BSPP	Ø R2 BSPT	Ø d	B	A	I	CH	PN
mm.	Poll.- Pouces Inch.- Zoll Pulgadas									
-	-	● 34. 68.02.02	1/8	1/8	4	26	10	10	12	350
-	-	● 34. 68.04.04	1/4	1/4	6	32	11	13	17	350
-	-	● 34. 68.06.06	3/8	3/8	8	35,5	13	13	19	350
-	-	● 34. 68.08.08	1/2	1/2	11	40	14	16	24	200
-	-	● 34. 68.12.12	3/4	3/4	17	45	17	18	32	200
-	-	● 34. 68.16.16	1"	1"	23	52	20	20	41	120
-	-	● 34. 68.20.20	1" 1/4	1" 1/4	30	55	21	21	46	105
-	-	● 34. 68.24.24	1" 1/2	1" 1/2	35	58	22	22	55	105
-	-	● 34. 68.32.32	2"	2"	46	66	25	25	65	70

NIPPLO MASCHIO - INTERMEDIO DIRITTO
FILETTATURA GAS CILINDRICA

UNION DOUBLE
BSPP

MALE NIPPLE STRAIGHT COUPLING
BSP PARALLEL THREAD

GEWINDEZAPFEN BSPP

ENLACE MACHO - RECTO ROSCA
GAS CILINDRICO

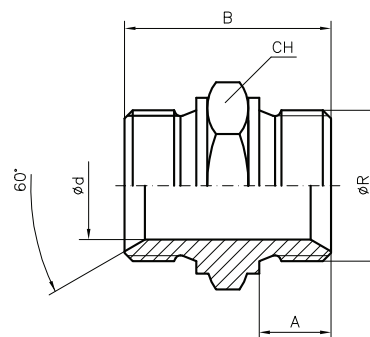

Ø TUBO-TUBE-ROHR		CODICE REFERENCE CODE BEST.-NR. REFERENCIA	Ø R BSPP	Ø d	B	A	CH	PN
mm.	Poll.- Pouces Inch.- Zoll Pulgadas							
-	-	● 34. 69.02.02	1/8	4	26,5	9	14	350
-	-	● 34. 69.04.04	1/4	6	32	11	19	350
-	-	● 34. 69.06.06	3/8	8	35	12	22	350
-	-	● 34. 69.08.08	1/2	11	40,5	14	27	200
-	-	● 34. 69.10.10	5/8	14	44,5	16	30	200
-	-	● 34. 69.12.12	3/4	17	45,5	16	32	200
-	-	● 34. 69.16.16	1"	23	52,5	19	41	120
-	-	● 34. 69.20.20	1" 1/4	30	57,5	20	50	105
-	-	● 34. 69.24.24	1" 1/2	35	61,5	22	55	105
-	-	● 34. 69.32.32	2"	46	68,5	25	70	70



RIDUZIONE BSPP
CONO 60°
INTERMEDIAIRE DE REDUCTION BSPP
SURFACE 60°
STUD ADAPTORS BSPP
CONED 60°
BSPP REDUZIERUNG / ERWEITERUNG
MIT 60°- KONUS
RACOR DE REDUCCIÓN ROSCADO BSPP
ASIENTO 60°

TIPO "A"
TYPE "A"
TYP "A"

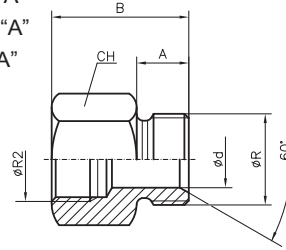

TIPO "B"
TYPE "B"
TYP "B"

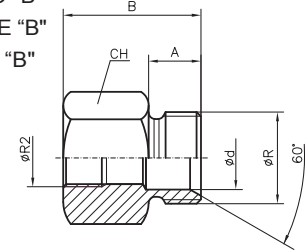

Ø TUBO-TUBE-ROHR		CODICE REFERENCE CODE BEST.-NR. REFERENCIA	Ø R BSPP	Ø R2 BSPP	Ø d	B	A	CH	PN	Tipo Type Typ
mm.	Poll.- Pouces Inch.- Zoll Pulgadas									
-	-	● 34. 73.06.04	3/8	1/4	8	37	12	22	350	B
-	-	● 34. 73.08.04	1/2	1/4	11	38	14	27	200	A
-	-	● 34. 73.08.06	1/2	3/8	11	45	14	30	200	B
-	-	● 34. 73.12.06	3/4	3/8	17	41,5	16	32	200	A
-	-	● 34. 73.12.08	3/4	1/2	17	47	16	32	200	B
-	-	● 34. 73.16.04	1"	1/4	23	43	19	41	120	A
-	-	● 34. 73.16.06	1"	3/8	23	44,5	19	41	120	A
-	-	● 34. 73.16.08	1"	1/2	23	50	19	41	120	A
-	-	● 34. 73.16.12	1"	3/4	23	52	19	41	120	B

TAPPO MASCHIO
OBTURATEUR MALE
MALE PLUG
VERSCHLUSS BUTZEN
TAPÓN MACHO

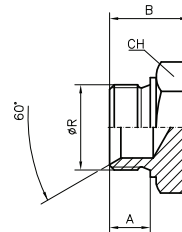

Ø TUBO-TUBE-ROHR		CODICE REFERENCE CODE BEST.-NR. REFERENCIA	Ø R BSPP	B	A	CH	PN
mm.	Poll.- Pouces Inch.- Zoll Pulgadas						
-	-	● 34. 75.00.02	1/8	14,5	9	14	350
-	-	● 34. 75.00.04	1/4	19	11	19	350
-	-	● 34. 75.00.06	3/8	20,5	12	22	350
-	-	● 34. 75.00.08	1/2	24	14	27	200
-	-	● 34. 75.00.10	5/8	26	16	30	200
-	-	● 34. 75.00.12	3/4	26,5	16	32	200
-	-	● 34. 75.00.16	1"	30,5	19	41	120
-	-	● 34. 75.00.20	1" 1/4	39	20	50	105
-	-	● 34. 75.00.24	1" 1/2	43	22	55	105
-	-	● 34. 75.00.32	2"	48,5	25	70	70

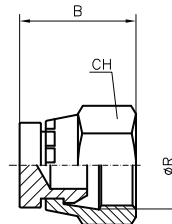

TAPPO FEMMINA
OBTURATEUR FEMELLE
FEMALE PLUG
VERSCHLUSS KAPPE
TAPÓN HEMBRA

Ø TUBO-TUBE-ROHR		CODICE REFERENCE CODE BEST.-NR. REFERENCIA	Ø R BSPP	B	CH	PN
mm.	Poll.- Pouces Inch.- Zoll Pulgadas					
-	-	● 34. 76.00.02	1/8	19,6	14	350
-	-	● 34. 76.00.04	1/4	20,7	19	350
-	-	● 34. 76.00.06	3/8	24,3	22	350
-	-	● 34. 76.00.08	1/2	26,4	27	200
-	-	● 34. 76.00.10	5/8	28,5	28 1)	200
-	-	● 34. 76.00.12	3/4	30,5	32	200
-	-	● 34. 76.00.16	1"	34,5	38 2)	120
-	-	● 34. 76.00.20	1" 1/4	42,5	50	105
-	-	● 34. 76.00.24	1" 1/2	45	55	105

1) AISI 316L CH = 30 2) AISI 316L CH = 41



ADATTATORE DIRITTO MASCHIO GAS CIL.
SVASATO 60° - FEMMINA GIREVOLE OGIVA 60°

ADAPTEUR DROIT FBSPP 60°
HBSPP 60°

STRAIGHT ADAPTER MALE BSPP CONED 60°
FEMALE CAP SURFACE 60°

AUSSENGEWINDE ÜBERWURFMUTTER
BSPP ADAPTER

ADAPTADOR MACHO TUERCA ROSCA
GAS ASIEN TO 60°

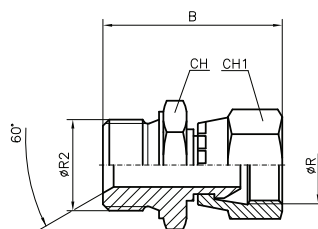

Ø TUBO-TUBE-ROHR		CODICE REFERENCE CODE BEST.-NR. REFERENCIA	Ø R BSPP	Ø R2 BSPP	B	CH1	CH	PN	
mm.	Poll.- Pouces Inch.- Zoll Pulgadas								
-	-	● 600.01.02.02	1/8	1/8	33	14	14	350	
-	-	● 600.01.04.04	1/4	1/4	36	19	19	350	
-	-	● 600.01.06.06	3/8	3/8	41	22	22	350	
-	-	● 600.01.08.08	1/2	1/2	46	27	27	200	
-	-	● 600.01.10.10	5/8	5/8	50	28 1)	30	200	
-	-	● 600.01.12.12	3/4	3/4	52	32	32	200	
-	-	● 600.01.16.16	1"	1"	60	38/41	41	120	
-	-	● 600.01.20.20	1" 1/4	1" 1/4	69	50	50	105	
-	-	● 600.01.24.24	1" 1/2	1" 1/2	75	55	55	70	

1) AISI 316L CH = 30

ADATTATORE DIRITTO RIDOTTO MASCHIO GAS CIL.
SVASATO 60° - FEMMINA GIREVOLE OGIVA 60°

ADAPTEUR DE REDUCTION DROIT FBSPP 60°
HBSPP 60°

REDUCED STRAIGHT ADAPTER MALE BSPP CONED 60°
FEMALE CAP SURFACE 60°

AUSSENGEWINDE ÜBERWURFMUTTER
BSPP ADAPTER REDUZIERUNG

ADAPTADOR REDUCIDO MACHO TUERCA ROSCA
GAS ASIEN TO 60°

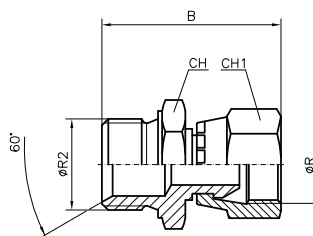

Ø TUBO-TUBE-ROHR		CODICE REFERENCE CODE BEST.-NR. REFERENCIA	Ø R2 BSPP	Ø R BSPP	B	CH1	CH	PN	
mm.	Poll.- Pouces Inch.- Zoll Pulgadas								
-	-	● 600.02.04.06	1/4	3/8	39,5	22	22	350	
-	-	● 600.02.06.04	3/8	1/4	38	19	22	350	
-	-	● 600.02.06.08	3/8	1/2	43	27	27	200	
-	-	● 600.02.08.04	1/2	1/4	41	19	27	200	
-	-	● 600.02.08.06	1/2	3/8	44	22	27	200	
-	-	● 600.02.08.12	1/2	3/4	49	32	32	200	
-	-	● 600.02.12.08	3/4	1/2	49	27	32	200	
-	-	● 600.02.16.12	1"	3/4	56	32	41	120	

CORPO: UNIONE GOMITO 90°

CORPS: UNIONE CODE 90°

BODY: ELBOW COUPLING 90°

KÖRPER: WINKELVERSCHRAUBUNG 90°

CUERPO: UNION CODO MACHO 90°

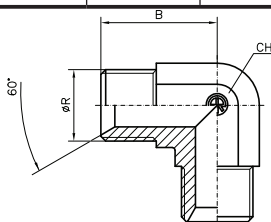

Ø TUBO-TUBE-ROHR		CODICE REFERENCE CODE BEST.-NR. REFERENCIA	Ø R BSPP	B	CH	PN	
mm.	Poll.- Pouces Inch.- Zoll Pulgadas						
-	-	● 60. 01.02.02	1/8	21 1)	11 1)	350	
-	-	● 60. 01.04.04	1/4	27	14	350	
-	-	● 60. 01.06.06	3/8	29	19	350	
-	-	● 60. 01.08.08	1/2	35	22	200	
-	-	● 60. 01.10.10	5/8	38	27	200	
-	-	● 60. 01.12.12	3/4	43	27	200	
-	-	● 60. 01.16.16	1"	45,5	33	120	
-	-	● 60. 01.20.20	1" 1/4	52	41	105	
-	-	● 60. 01.24.24	1" 1/2	59	48	105	

1) AISI 316L CH = 14, B = 25



CORPO: UNIONE GOMITO 90° BSPP/BSPT
CORPS: UNIONE CODE 90° BSPP/BSPT
BODY: ELBOW COUPLING 90° BSPP/BSPT
KÖRPER: WINKELVERSCHRAUBUNG 90° BSPP/BSPT
CUERPO: UNION CODO MACHO 90° BSPP/BSPT

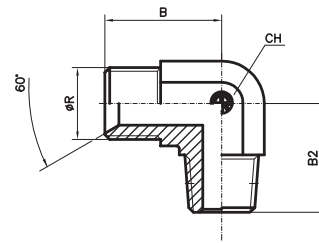

Ø TUBO-TUBE-ROHR		CODICE REFERENCE CODE BEST.-NR. REFERENCIA	Ø R BSPP	Ø R2 BSPT	B	B2	CH	PN	
mm.	Poll.- Pouces Inch.- Zoll Pulgadas								
-	-	● 60. 02.02.02	1/8	1/8	21	19.8	11 ¹⁾	350	
-	-	● 60. 02.04.04	1/4	1/4	27	27.7	14	350	
-	-	● 60. 02.06.06	3/8	3/8	29	31	19	350	
-	-	● 60. 02.08.08	1/2	1/2	35	37.3	22	200	
-	-	● 60. 02.10.10	5/8	5/8	38	40	27	200	
-	-	● 60. 02.12.12	3/4	3/4	43	40.4	27	200	
-	-	● 60. 02.16.16	1"	1"	45.5	50	33	120	
-	-	● 60. 02.20.20	1" 1/4	1" 1/4	52	59.6	41	105	
-	-	● 60. 02.24.24	1" 1/2	1" 1/2	59	67.1	48	105	

1) AISI 316L CH = 14, B = 25, B2 = 25

● Disponibile dopo esaurimento TN155 - Disponible apres apuisement TN155 - After exhausting of TN155 available -
Nach Ausverkauf von TN155 verfügbar - Disponible después finalización existencias TN155

GOMITO MASCHIO 45°
GAS CILINDRICO - GAS CONICO
COUDE MALE 45°
GAZ CYLINDRIQUE - GAZ CONIQUE
ELBOW MALE COUPLING 45°
BSPP - BSPT
WINKLEINSCHRAUBVERSCHRAUBUNG 45°
BSPP - BSPT
CODO MACHO 45°
BSPP - BSPT

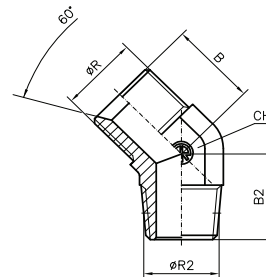

Ø TUBO-TUBE-ROHR		CODICE REFERENCE CODE BEST.-NR. REFERENCIA	Ø R BSPP	Ø R2 BSPT	B	B2	CH	PN	
mm.	Poll.- Pouces Inch.- Zoll Pulgadas								
-	-	● 60. 03.04.04	1/4	1/4	22	21,8	14 ¹⁾	350	
-	-	● 60. 03.06.06	3/8	3/8	23,5	24,1	19	350	
-	-	● 60. 03.08.08	1/2	1/2	28,5	29,7	22	200	
-	-	● 60. 03.12.12	3/4	3/4	31,5	30,5	27	200	
-	-	● 60. 03.16.16	1"	1"	37	37,6	33	120	

1) AISI 316L CH = 19



CORPO: ADATTATORE ORIENTABILE 45°
MASCHIO-MASCHIO CON O.RING
CORPS: COUDE ORIENTABLE 45° MALE-MALE
AVEC O.RING
BODY: 45° MALE-MALE O.RING
ADJUSTABLE ADAPTOR
STUTZEN: 45° EINSTELLBARER EINSCHRAUBADAPTER
MIT O.RING
CUERPO: ADAPTADOR ORIENTABLE 45° MACHO-MACHO
CON JUNTA TORICA

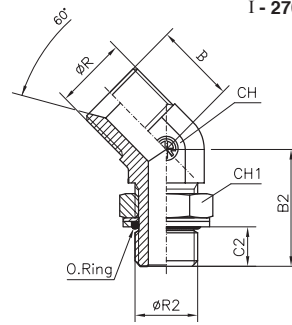

Ø TUBO-TUBE-ROHR		CODICE REFERENCE CODE BEST.-NR. REFERENCIA	Ø R BSPP	Ø R2 BSPP	B	B2	C2	CH	CH1	PN
mm.	Poll.- Pouces Inch.- Zoll Pulgadas									
-	-	● 60.04.02.02	1/8	1/8	20	26	6.3	14	14	350
-	-	● 60.04.04.02	1/4	1/8	22	27	6.3	14	14	350
-	-	● 60.04.04.04	1/4	1/4	22	29	9.5	14	19	350
-	-	● 60.04.06.04	3/8	1/4	23.5	29.5	9.5	19	19	350
-	-	● 60.04.06.06	3/8	3/8	23.5	33	9.5	19	22	350
-	-	● 60.04.06.08	3/8	1/2	28.5	38.5	13.0	22	27	200
-	-	● 60.04.08.06	1/2	3/8	28.5	34.5	9.5	22	22	200
-	-	● 60.04.08.08	1/2	1/2	28.5	38.5	13.0	22	27	200
-	-	● 60.04.12.08	3/4	1/2	31.5	40	13.0	27	27	200
-	-	● 60.04.12.12	3/4	3/4	31.5	44	13.0	27	36	200
-	-	● 60.04.16.12	1"	3/4	37	47.5	13.0	33	36	120
-	-	● 60.04.16.16	1"	1"	37	47.5	16.0	33	41	120
-	-	● 60.04.20.16	1"1/4	1"	39	48.5	16.0	41	41	105
-	-	● 60.04.20.20	1"1/4	1"1/4	39	48.5	16.0	41	50	105
-	-	● 60.04.24.20	1"1/2	1"1/4	46	48.5	16.0	48	50	105
-	-	● 60.04.24.24	1"1/2	1"1/2	46	48.5	16.0	48	55	105

CORPO: ADATTATORE ORIENTABILE 90°
MASCHIO-MASCHIO CON O.RING
CORPS: COUDE ORIENTABLE 90° MALE-MALE
AVEC O.RING
BODY: 90° MALE-MALE O.RING
ADJUSTABLE ADAPTOR
STUTZEN: 90° EINSTELLBARER EINSCHRAUBADAPTER
MIT O.RING
CUERPO: ADAPTADOR ORIENTABLE 90° MACHO-MACHO
CON JUNTA TORICA

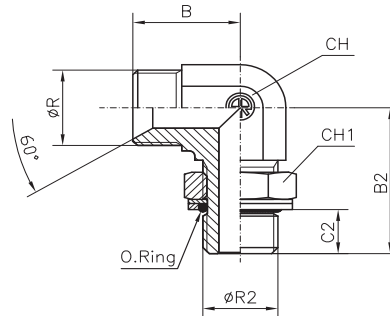

Ø TUBO-TUBE-ROHR		CODICE REFERENCE CODE BEST.-NR. REFERENCIA	Ø R BSPP	Ø R2 BSPP	B	B2	C2	CH	CH1	PN
mm.	Poll.- Pouces Inch.- Zoll Pulgadas									
-	-	● 60.05.02.02	1/8	1/8	21 ¹⁾	26 ¹⁾	6.3	11 ¹⁾	14	350
-	-	● 60.05.04.02	1/4	1/8	27	30	6.3	14	14	350
-	-	● 60.05.04.04	1/4	1/4	27	32	9.5	14	19	350
-	-	● 60.05.06.04	3/8	1/4	29	33.5	9.5	19	19	350
-	-	● 60.05.06.06	3/8	3/8	29	37	9.5	19	22	350
-	-	● 60.05.06.08	3/8	1/2	35	43	13.0	22	27	200
-	-	● 60.05.08.06	1/2	3/8	35	39.5	9.5	22	22	200
-	-	● 60.05.08.08	1/2	1/2	35	43	13.0	22	27	200
-	-	● 60.05.12.08	3/4	1/2	43	45.5	13.0	27	27	200
-	-	● 60.05.12.12	3/4	3/4	43	49.5	13.0	27	36	200
-	-	● 60.05.16.12	1"	3/4	45.5	50.5	13.0	33	36	120
-	-	● 60.05.16.16	1"	1"	45.5	52.5	16.0	33	41	120
-	-	● 60.05.20.16	1"1/4	1"	52	57	16.0	41	41	105
-	-	● 60.05.20.20	1"1/4	1"1/4	52	57	16.0	41	50	105
-	-	● 60.05.24.20	1"1/2	1"1/4	59	60.5	16.0	48	50	105
-	-	● 60.05.24.24	1" 1/2	1"1/2	59	60.5	16.0	48	55	105

1) AISI 316L CH = 14 B = 25 B2 = 29



CORPO: UNIONE GOMITO 90°
CON DADO GIREVOLE

CORPS: UNION COUDE 90°
ECROU PIVOTANT

BODY: ELBOW COUPLING 90°
WITH ROTARY NUT

KÖRPER: WINKELVERSCHRAUBUNG 90°
MIT DREHMUTTER

CUERPO: UNION CODO 90°
CON TUERCA LOCA

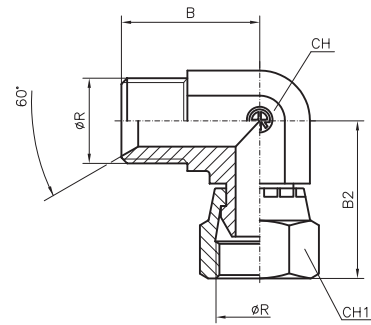

Ø TUBO-TUBE-ROHR		CODICE REFERENCE CODE BEST.-NR. REFERENCIA	Ø R BSPP	B	B2	CH	CH1	PN	
mm.	Poll.- Pouces Inch.- Zoll Pulgadas								
-	-	● 60. 09.02.02	1/8	17 2)	22 2)	11 2)	14	350	
-	-	● 60. 09.04.04	1/4	27	26	14	19	350	
-	-	● 60. 09.06.06	3/8	29	31	19	22	350	
-	-	● 60. 09.08.08	1/2	35	36	22	27	200	
-	-	● 60. 09.10.10	5/8	38	40	27	30	200	
-	-	● 60. 09.12.12	3/4	43	40	27	32	200	
-	-	● 60. 09.16.16	1"	45,5	53	33	38 1)	120	
-	-	● 60. 09.20.20	1" 1/4	52	57	41	50	105	
-	-	● 60. 09.24.24	1" 1/2	59	65,5	48	55	105	

1) AISI 316L CH = 41

2) AISI 316L CH = 14 B = 25 B2 = 28,5

UNIONE GOMITO 90° CON DADO GIREVOLE

UNION COUDE 90° ECROU PIVOTANT

ELBOW COUPLING 90° WITH ROTARY NUT

WINKELVERSCHRAUBUNG 90° MIT DREHMUTTER

UNION CODO 90° CON TUERCA LOCA

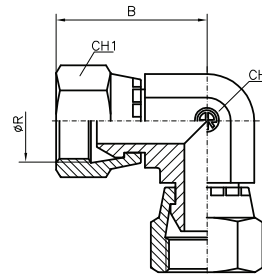

Ø TUBO-TUBE-ROHR		CODICE REFERENCE CODE BEST.-NR. REFERENCIA	Ø R BSPP	B	CH	CH1	PN	
mm.	Poll.- Pouces Inch.- Zoll Pulgadas							
-	-	● 60. 10.02.02	1/8	22 2)	11 2)	14	350	
-	-	● 60. 10.04.04	1/4	27,2	14	19	350	
-	-	● 60. 10.06.06	3/8	32,3	19	22	350	
-	-	● 60. 10.08.08	1/2	36,4	22	27	200	
-	-	● 60. 10.10.10	5/8	39	27	30	200	
-	-	● 60. 10.12.12	3/4	42,5	27	32	200	
-	-	● 60. 10.16.16	1"	53	33	38 1)	120	
-	-	● 60. 10.20.20	1" 1/4	58	41	50	105	
-	-	● 60. 10.24.24	1" 1/2	68,5	48	55	105	

1) AISI 316L CH = 41

2) AISI 316L CH = 14 B = 28,5



UNIONE GOMITO 90° FEMMINA NPT
UNION COUDE 90° FEMELLE NPT
ELBOW FEMALE COUPLING 90° NPT
WINKELAUFSCRAUBVERSCHRAUBUNG 90° NPT
UNION CODO 90° HEMBRA NPT

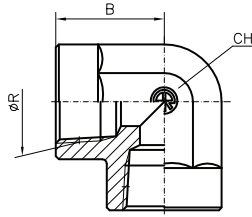

Ø TUBO-TUBE-ROHR		CODICE REFERENCE CODE BEST.-NR. REFERENCIA	Ø R NPT	B	CH	PN	
mm.	Poll.- Pouces Inch.- Zoll Pulgadas						
-	-	● 60. 14.02.02	1/8	16,8	14	350	
-	-	● 60. 14.04.04	1/4	22,4	19	350	
-	-	● 60. 14.06.06	3/8	25,9	22	315	
-	-	● 60. 14.08.08	1/2	31,2	27	210	
-	-	● 60. 14.12.12	3/4	34,5	33	210	
-	-	● 60. 14.16.16	1"	41,4	41	120	
-	-	● 60. 14.20.20	1" 1/4	43,2	48	105	
-	-	● 60. 14.24.24	1" 1/2	62	64	105	

UNIONE GOMITO 90° FEMMINA BSPP
UNION COUDE 90° FEMELLE BSPP
ELBOW FEMALE COUPLING 90° BSPP
WINKELVERSCHRAUBVERSCHRAUBUNG 90° BSPP
UNION CODO 90° HEMBRA BSPP

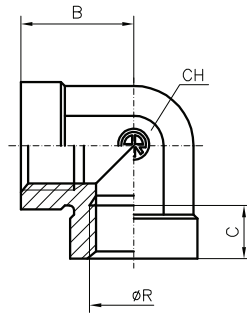

Ø TUBO-TUBE-ROHR		CODICE REFERENCE CODE BEST.-NR. REFERENCIA	Ø R BSPP	B	C	CH	PN	
mm.	Poll.- Pouces Inch.- Zoll Pulgadas							
-	-	● 60. 15.02.02	1/8	16,8	10	14	350	
-	-	● 60. 15.04.04	1/4	23	13	19	350	
-	-	● 60. 15.06.06	3/8	26	13	22	315	
-	-	● 60. 15.08.08	1/2	31	15	27	210	
-	-	● 60. 15.12.12	3/4	36	17	33	210	
-	-	● 60. 15.16.16	1"	42,5	20	41	120	
-	-	● 60. 15.20.20	1" 1/4	47	22	48	105	
-	-	● 60. 15.24.24	1" 1/2	62	24	64	105	

UNIONE GOMITO 45° FEMMINA NPT
UNION COUDE 45° FEMELLE NPT
ELBOW FEMALE COUPLING 45° NPT
WINKELVERSCHRAUBVERSCHRAUBUNG 45° NPT
UNION CODO 45° HEMBRA NPT

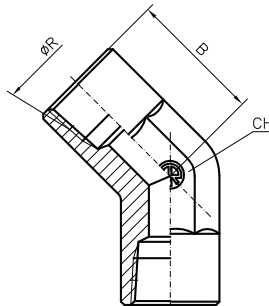

Ø TUBO-TUBE-ROHR		CODICE REFERENCE CODE BEST.-NR. REFERENCIA	Ø R NPT	B	CH	PN	
mm.	Poll.- Pouces Inch.- Zoll Pulgadas						
-	-	● 60. 16.04.04	1/4	17,5	19	350	
-	-	● 60. 16.06.06	3/8	19	22	315	
-	-	● 60. 16.08.08	1/2	23,9	27	210	
-	-	● 60. 16.12.12	3/4	25,4	33	210	
-	-	● 60. 16.16.16	1"	30,2	41	120	



GOMITO MASCHIO RIDOTTO 90° BSPT
COUDE MALE DE REDUCTION 90° BSPT
REDUCED ELBOW MALE COUPLING 90° BSPT
WINKELVERSCHRAUBVERSCHRAUBUNG 90° BSPT
CODO MACHO REDUCIDO 90° BSPT

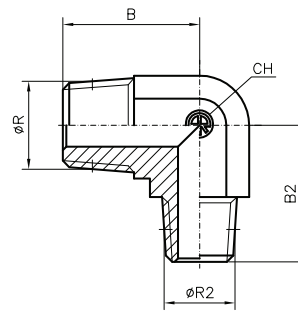

Ø TUBO-TUBE-ROHR		CODICE REFERENCE CODE BEST.-NR. REFERENCIA	Ø R BSPT	Ø R2 BSPT	B	B2	CH	PN
mm.	Poll.- Pouces Inch.- Zoll Pulgadas							
-	-	● 60. 19.06.04	3/8	1/4	31	31	19	420
-	-	● 60. 19.08.06	1/2	3/8	37,3	32,5	22	420
-	-	● 60. 19.12.08	3/4	1/2	40,4	40,4	27	280

GOMITO MASCHIO 90° BSPT
COUDE MALE 90° BSPT
MALE COUPLING 90° BSPT
WINKELVERSCHRAUBVERSCHRAUBUNG 90° BSPT
CODO MACHO 90° BSPT

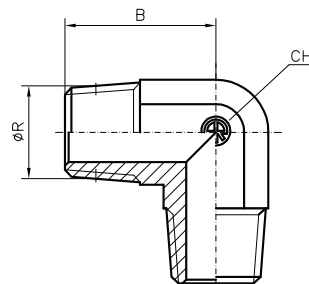

Ø TUBO-TUBE-ROHR		CODICE REFERENCE CODE BEST.-NR. REFERENCIA	Ø R BSPT	B	CH	PN
mm.	Poll.- Pouces Inch.- Zoll Pulgadas					
-	-	● 60. 20.02.02	1/8	19,8 ¹⁾	11 ¹⁾	420
-	-	● 60. 20.04.04	1/4	27,7	14	420
-	-	● 60. 20.06.06	3/8	31	19	420
-	-	● 60. 20.08.08	1/2	37,3	22	420
-	-	● 60. 20.12.12	3/4	40,4	27	280
-	-	● 60. 20.16.16	1"	50	33	210
-	-	● 60. 20.20.20	1" 1/4	59,6	41	210
-	-	● 60. 20.24.24	1" 1/2	67,1	48	210

1) AISI 316L CH = 14 B = 23,5

GOMITO MASCHIO RIDOTTO 90° NPT
COUDE MALE DE REDUCTION 90° NPT
REDUCED ELBOW MALE COUPLING 90° NPT
WINKELVERSCHRAUBVERSCHRAUBUNG 90° NPT
CODO MACHO REDUCIDO 90° NPT

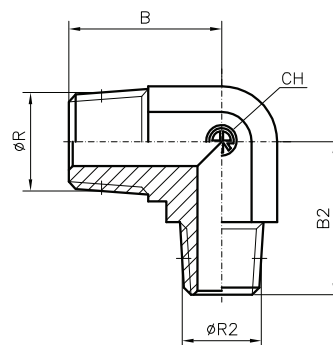

Ø TUBO-TUBE-ROHR		CODICE REFERENCE CODE BEST.-NR. REFERENCIA	Ø R NPT	Ø R2 NPT	B	B2	CH	PN
mm.	Poll.- Pouces Inch.- Zoll Pulgadas							
-	-	● 60. 21.06.04	3/8	1/4	31	31	19	420
-	-	● 60. 21.08.06	1/2	3/8	37,3	32,5	22	420
-	-	● 60. 21.12.08	3/4	1/2	40,4	40,4	27	280



GOMITO MASCHIO 90° NPT
COUDE MALE 90° NPT
MALE COUPLING 90° NPT
WINKELVERSCHRAUBVERSCHRAUBUNG 90° NPT
CODO MACHO 90° NPT

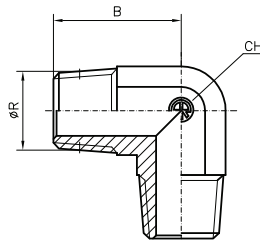

Ø TUBO-TUBE-ROHR		CODICE REFERENCE CODE BEST.-NR. REFERENCIA	Ø R NPT	B	CH	PN	
mm.	Poll.- Pouces Inch.- Zoll Pulgadas						
-	-	● 60. 22.02.02	1/8	19,8 1)	11 1)	420	
-	-	● 60. 22.04.04	1/4	27,7	14	420	
-	-	● 60. 22.06.06	3/8	31	19	420	
-	-	● 60. 22.08.08	1/2	37,3	22	420	
-	-	● 60. 22.12.12	3/4	40,4	27	280	
-	-	● 60. 22.16.16	1"	50	33	210	
-	-	● 60. 22.20.20	1" 1/4	59,6	41	210	
-	-	● 60. 22.24.24	1" 1/2	67,1	48	210.	

1) AISI 316L CH = 14 B = 23,5

GOMITO RIDOTTO MASCHIO
FEMMINA 90° NPT
COUDE DE REDUCTION MALE
FEMELLE 90° NPT
REDUCED ELBOW MALE
FEMALE 90° NPT
WINKELVERSCHRAUBVERSCHRAUBUNG 90° NPT
CODO MACHO
HEMBRA 90° NPT

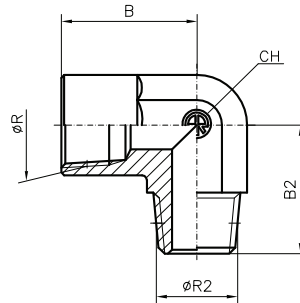

Ø TUBO-TUBE-ROHR		CODICE REFERENCE CODE BEST.-NR. REFERENCIA	Ø R NPT	Ø R2 NPT	B	B2	CH	PN	
mm.	Poll.- Pouces Inch.- Zoll Pulgadas								
-	-	● 60. 25.02.04	1/8	1/4	16,8	27,7	14	350	
-	-	● 60. 25.04.06	1/4	3/8	22,4	31	19	350	
-	-	● 60. 25.06.08	3/8	1/2	31,7	37,3	22	210	
-	-	● 60. 25.08.06	1/2	3/8	31,2	32,5	27	210	
-	-	● 60. 25.08.12	1/2	3/4	31,2	40,4	27	210	
-	-	● 60. 25.12.08	3/4	1/2	34,5	40,4	33	210	

GOMITO MASCHIO
FEMMINA 90° NPT
COUDE MALE
FEMELLE 90° NPT
ELBOW MALE
FEMALE 90° NPT
WINKELVERSCHRAUBVERSCHRAUBUNG 90° NPT
CODO MACHO
HEMBRA 90° NPT

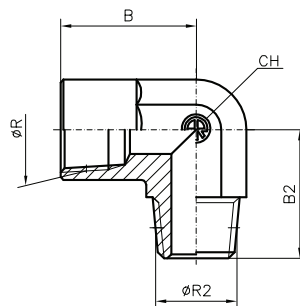

Ø TUBO-TUBE-ROHR		CODICE REFERENCE CODE BEST.-NR. REFERENCIA	Ø R NPT	Ø R2 NPT	B	B2	CH	PN	
mm.	Poll.- Pouces Inch.- Zoll Pulgadas								
-	-	● 60. 26.02.02	1/8	1/8	16,8	19,8	14	350	
-	-	● 60. 26.04.04	1/4	1/4	22,4	27,7	19	350	
-	-	● 60. 26.06.06	3/8	3/8	25,9	31	22	315	
-	-	● 60. 26.08.08	1/2	1/2	31,2	37,3	27	210	
-	-	● 60. 26.12.12	3/4	3/4	34,5	40,4	33	210	
-	-	● 60. 26.16.16	1"	1"	41,4	50	41	120	
-	-	● 60. 26.20.20	1" 1/4	1" 1/4	43,2	60,5	48	105	
-	-	● 60. 26.24.24	1" 1/2	1" 1/2	62	67,1	64	105	



GOMITO MASCHIO
FEMMINA 45°NPT

COUDE MALE
FEMELLE 45° NPT

ELBOW MALE
FEMALE 45° NPT

WINKELVERSCHRAUBVERSCHRAUBUNG
45° NPT

CODO MACHO
HEMBRA 45°NPT

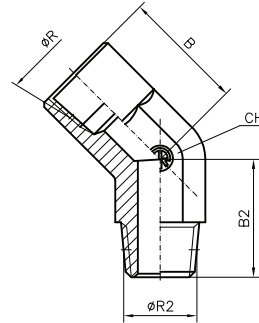

Ø TUBO-TUBE-ROHR		CODICE REFERENCE CODE BEST.-NR. REFERENCIA	Ø R NPT	Ø R2 NPT	B	B2	CH	PN	
mm.	Poll.- Pouces Inch.- Zoll Pulgadas								
-	-	● 60. 27.02.02	1/8	1/8	11,9 ¹⁾	18,3	14 ¹⁾	350	
-	-	● 60. 27.04.04	1/4	1/4	15,7	26,7	19	350	
-	-	● 60. 27.06.06	3/8	3/8	18,3	26,9	22	315	
-	-	● 60. 27.08.08	1/2	1/2	23,1	34	27	210	
-	-	● 60. 27.12.12	3/4	3/4	24,6	35,1	33	210	
-	-	● 60. 27.16.16	1"	1"	28,4	43,7	41	120	

1) AISI 316L CH = 19 B = 13,4

GOMITO RIDOTTO MASCHIO BSPT
FEMMINA BSPP 90°

COUDE DE REDUCTION MALE BSPT
FEMELLE BSPP 90°

REDUCED ELBOW MALE BSPT
FEMALE BSPP 90°

WINKELVERSCHRAUBVERSCHRAUBUNG
90° BSPT/BSPP

CODO MACHO BSPT
HEMBRA BSPP 90°

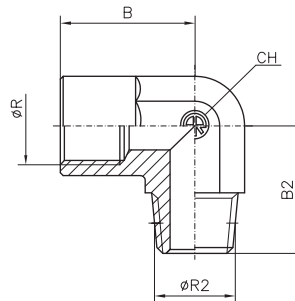

Ø TUBO-TUBE-ROHR		CODICE REFERENCE CODE BEST.-NR. REFERENCIA	Ø R BSPP	Ø R2 BSPT	B	B2	CH	PN	
mm.	Poll.- Pouces Inch.- Zoll Pulgadas								
-	-	● 60. 35.02.04	1/8	1/4	16,8	27,7	14	350	
-	-	● 60. 35.04.06	1/4	3/8	22,4	31	19	350	
-	-	● 60. 35.06.08	3/8	1/2	31,7	37,3	22	210	
-	-	● 60. 35.08.06	1/2	3/8	31,2	32,5	27	210	
-	-	● 60. 35.08.12	1/2	3/4	31,2	40,4	27	210	
-	-	● 60. 35.12.08	3/4	1/2	34,5	40,4	33	210	

GOMITO MASCHIO BSPT
FEMMINA BSPP 90°

COUDE MALE BSPT
FEMELLE BSPP 90°

ELBOW MALE BSPT
FEMALE BSPP 90°

WINKELVERSCHRAUBVERSCHRAUBUNG
90° BSPT/BSPP

CODO MACHO BSPT
HEMBRA BSPP 90°

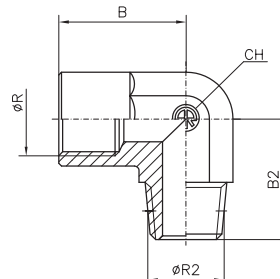

Ø TUBO-TUBE-ROHR		CODICE REFERENCE CODE BEST.-NR. REFERENCIA	Ø R BSPP	Ø R2 BSPT	B	B2	CH	PN	
mm.	Poll.- Pouces Inch.- Zoll Pulgadas								
-	-	● 60. 36.02.02	1/8	1/8	16,8	19,8	14	350	
-	-	● 60. 36.04.04	1/4	1/4	22,4	27,7	19	350	
-	-	● 60. 36.06.06	3/8	3/8	25,9	31	22	315	
-	-	● 60. 36.08.08	1/2	1/2	31,2	37,3	27	210	
-	-	● 60. 36.12.12	3/4	3/4	34,5	40,4	33	210	
-	-	● 60. 36.16.16	1"	1"	41,4	50	41	120	
-	-	● 60. 36.20.20	1" 1/4	1" 1/4	43,2	60,5	48	105	
-	-	● 60. 36.24.24	1" 1/2	1" 1/2	62	67,1	64	105	



GOMITO MASCHIO BSPT FEMMINA BSPP 45°
COUDE MALE BSPT FEMELLE BSPP 45°
ELBOW MALE BSPT FEMALE BSPP 45°
WINKELVERSCHRAUBVERSCHRAUBUNG 45° BSPT/BSPP
CODO MACHO BSPT HEMBRA BSPP 45°

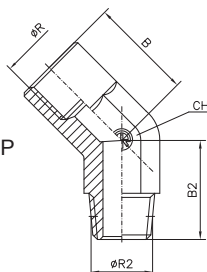

Ø TUBO-TUBE-ROHR		CODICE REFERENCE CODE BEST.-NR. REFERENCIA	Ø R BSPP	Ø R2 BSPT	B	B2	CH	PN
mm.	Poll.- Pouces Inch.- Zoll Pulgadas							
-	-	● 60. 37.02.02	1/8	1/8	11,9 1)	18,3	14 1)	350
-	-	● 60. 37.04.04	1/4	1/4	15,7	26,7	19	350
-	-	● 60. 37.06.06	3/8	3/8	18,3	26,9	22	315
-	-	● 60. 37.08.08	1/2	1/2	23,1	34	27	210
-	-	● 60. 37.12.12	3/4	3/4	24,6	35,1	33	210
-	-	● 60. 37.16.16	1"	1"	28,4	43,7	41	120
-	-	● 60. 37.20.20	1" 1/4	1" 1/4	34,5	45,2	48	105
-	-	● 60. 37.24.24	1" 1/2	1" 1/2	42,2	52,7	64	105

1) AISI 316L CH = 19 B = 13,4

UNIONE GOMITO 45° FEMMINA BSPP
UNION COUDE 45° FEMELLE BSPP
ELBOW FEMALE COUPLING 45° BSPP
WINKELVERSCHRAUBVERSCHRAUBUNG 45° BSPP
UNION CODO 45° HEMBRA BSPP

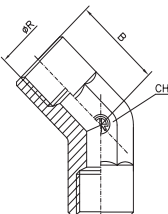

Ø TUBO-TUBE-ROHR		CODICE REFERENCE CODE BEST.-NR. REFERENCIA	Ø R BSPP	B	CH	PN
mm.	Poll.- Pouces Inch.- Zoll Pulgadas					
-	-	● 60. 38.02.02	1/8	11,9 1)	14 1)	350
-	-	● 60. 38.04.04	1/4	17,5	19	350
-	-	● 60. 38.06.06	3/8	19	22	315
-	-	● 60. 38.08.08	1/2	23,9	27	210
-	-	● 60. 38.12.12	3/4	25,4	33	210
-	-	● 60. 38.16.16	1"	30,2	41	120
-	-	● 60. 38.20.20	1" 1/4	37,2	48	105
-	-	● 60. 38.24.24	1" 1/2	42,2	64	105

1) AISI 316L CH = 19 B = 13,4

CORPO: UNIONE GOMITO 45°
CON DADO GIREVOLE
CORPS: UNION COUDE 45°
ECROU PIVOTANT
BODY: ELBOW COUPLING 45°
WITH ROTARY NUT
KÖRPER: WINKELVERSCHRAUBUNG 45°
MIT DREHMÜTTER
CUERPO: UNION CODO 45°
CON TUERCA LOCA

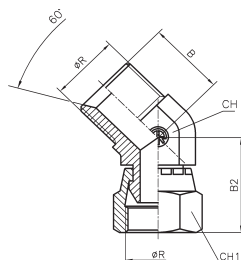

Ø TUBO-TUBE-ROHR		CODICE REFERENCE CODE BEST.-NR. REFERENCIA	Ø R BSPP	B	B2	CH	CH1	PN
mm.	Poll.- Pouces Inch.- Zoll Pulgadas							
-	-	● 60. 39.02.02	1/8	22	26	14 2)	14	350
-	-	● 60. 39.04.04	1/4	22	26	14 2)	19	350
-	-	● 60. 39.06.06	3/8	23,5	30	19	22	350
-	-	● 60. 39.08.08	1/2	28,5	34	22	27	200
-	-	● 60. 39.10.10	5/8	29	41	27	28	200
-	-	● 60. 39.12.12	3/4	31,5	42	27	32	200
-	-	● 60. 39.16.16	1"	37	47	33	38 1)	120
-	-	● 60. 39.20.20	1" 1/4	39	51	41	50	105
-	-	● 60. 39.24.24	1" 1/2	46	60	48	55	105

1) AISI 316L CH = 41 2) AISI 316L CH = 19



UNIONE A "T"
UNION "T"
EQUAL TEES
T-VERSCHRAUBUNG
UNION TE MACHO-MACHO

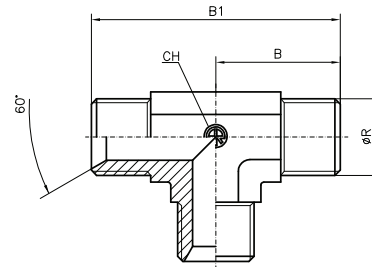

Ø TUBO-TUBE-ROHR		CODICE REFERENCE CODE BEST.-NR. REFERENCIA	Ø R BSPP	B	B1	CH	PN
mm.	Poll.- Pouces Inch.- Zoll Pulgadas						
-	-	● 60. 51.02.02	1/8	17 ¹⁾	34 ¹⁾	11 ¹⁾	350
-	-	● 60. 51.04.04	1/4	27	54	14	350
-	-	● 60. 51.06.06	3/8	29	58	19	350
-	-	● 60. 51.08.08	1/2	35	70	22	200
-	-	● 60. 51.10.10	5/8	38	76	27	200
-	-	● 60. 51.12.12	3/4	43	86	27	200
-	-	● 60. 51.16.16	1"	45,5	91	33	120
-	-	● 60. 51.20.20	1" 1/4	52 ²⁾	104 ²⁾	41	105
-	-	● 60. 51.24.24	1" 1/2	59 ³⁾	118 ³⁾	48 ³⁾	105

1) AISI 316L CH = 14 B = 27 B1 = 54
3) AISI 316L CH = 50 B = 62,5 B1 = 125

2) AISI 316L B = 53,5 B1 = 107

CORPO: ADATTATORE ORIENTABILE A "T"
MASCIO-MASCIO CON O.RING

CORPS: COUDE ORIENTABLE "T" MALE-MALE
AVEC O.RING

BODY: "T" MALE-MALE O.RING
ADJUSTABLE ADAPTOR

STUTZEN: "T" EINSTELLBARER EINSCHRAUBADAPTER
MIT O.RING

CUERPO: ADAPTADOR ORIENTABLE "T" MACHO-MACHO
CON JUNTA TORICA

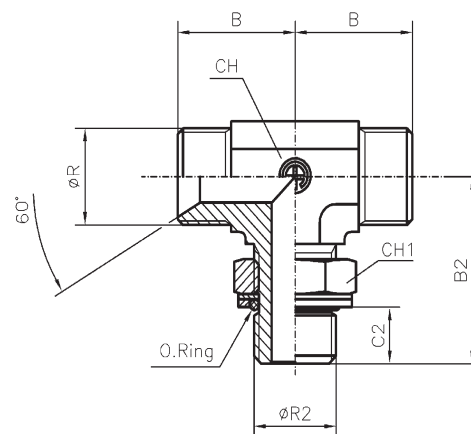

Ø TUBO-TUBE-ROHR		CODICE REFERENCE CODE BEST.-NR. REFERENCIA	Ø R BSPP	Ø R2 BSPP	B	B2	C2	CH	CH1	PN
mm.	Poll.- Pouces Inch.- Zoll Pulgadas									
-	-	● 60.53.02.02	1/8	1/8	21 ¹⁾	26 ¹⁾	6.3	11 ¹⁾	14	350
-	-	● 60.53.04.02	1/4	1/8	27	30	6.3	14	14	350
-	-	● 60.53.04.04	1/4	1/4	27	32	9.5	14	19	350
-	-	● 60.53.06.04	3/8	1/4	29	33.5	9.5	19	19	350
-	-	● 60.53.06.06	3/8	3/8	29	37	9.5	19	22	350
-	-	● 60.53.06.08	3/8	1/2	35	43	13.0	22	27	200
-	-	● 60.53.08.06	1/2	3/8	35	39.5	9.5	22	22	200
-	-	● 60.53.08.08	1/2	1/2	35	43	13.0	22	27	200
-	-	● 60.53.12.08	3/4	1/2	43	45.5	13.0	27	27	200
-	-	● 60.53.12.12	3/4	3/4	43	49.5	13.0	27	36	200
-	-	● 60.53.16.12	1"	3/4	45.5	50.5	13.0	33	36	120
-	-	● 60.53.16.16	1"	1"	45.5	52.5	16.0	33	41	120
-	-	● 60.53.20.16	1"1/4	1"	52	57	16.0	41	41	105
-	-	● 60.53.20.20	1"1/4	1"1/4	52	57	16.0	41	50	105
-	-	● 60.53.24.20	1"1/2	1"1/4	59	60.5	16.0	48	50	105
-	-	● 60.53.24.24	1" 1/2	1"1/2	59	60.5	16.0	48	55	105

1) AISI 316L CH = 14 B = 25 B2 = 29



“T” DI LINEA CON DADO GIREVOLE
“T” DE LIGNE ECROU PIVOTANT
“T” OF LINE WITH ROTARY NUT
LINIEN-T MIT DREHMUTTER
TE MACHO TUERCA LOCA CENTRAL

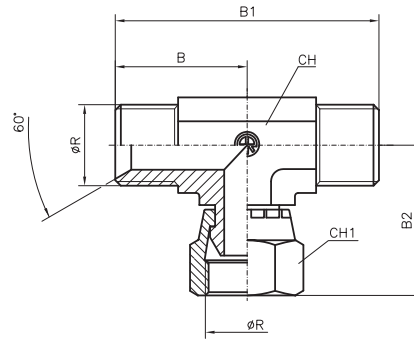

Ø TUBO-TUBE-ROHR		CODICE REFERENCE CODE BEST.-NR. REFERENCIA	Ø R BSPP	B	B1	B2	CH	CH1	PN
mm.	Poll.- Pouces Inch.- Zoll Pulgadas								
-	-	● 60. 55.02.02	1/8	21 ¹⁾	42 ¹⁾	22	11 ¹⁾	14	350
-	-	● 60. 55.04.04	1/4	27	54	26	14	19	350
-	-	● 60. 55.06.06	3/8	29	58	31	19	22	350
-	-	● 60. 55.08.08	1/2	35	70	36	22	27	200
-	-	● 60. 55.10.10	5/8	38	76	41	27	28/30 ²⁾	200
-	-	● 60. 55.12.12	3/4	43	86	40	27	32	200
-	-	● 60. 55.16.16	1"	45,5	91	53	33	38	120
-	-	● 60. 55.20.20	1" 1/4	52 ³⁾	104 ³⁾	58	41	50	105
-	-	● 60. 55.24.24	1" 1/2	59 ⁴⁾	118 ⁴⁾	68,5	48 ⁴⁾	55	105

1) AISI 316L CH = 14 B = 27 B1 = 54
3) AISI 316L B = 53.5 B1 = 107

2) AISI 316L CH = 30
4) AISI 316L CH = 50 B = 62,5 B1 = 125

CORPO: ADATTATORE ORIENTABILE A "L"
MASCHIO-MASCHIO CON O.RING
CORPS: COUDE ORIENTABLE "L" MALE-MALE
AVEC O.RING
BODY: "L" MALE-MALE O.RING
ADJUSTABLE ADAPTOR
STUTZEN: "L" EINSTELLBARER EINSCHRAUBADAPTER
MIT O.RING
CUERPO: ADAPTADOR ORIENTABLE "L" MACHO-MACHO
CON JUNTA TORICA

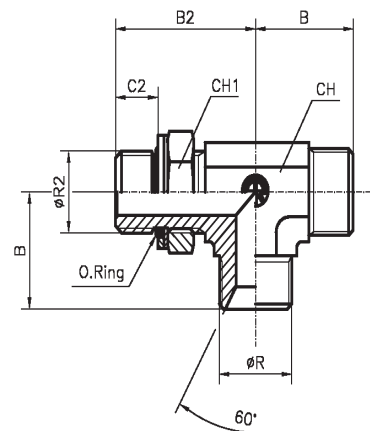

Ø TUBO-TUBE-ROHR		CODICE REFERENCE CODE BEST.-NR. REFERENCIA	Ø R BSPP	Ø R2 BSPP	B	B2	C2	CH	CH1	PN
mm.	Poll.- Pouces Inch.- Zoll Pulgadas									
-	-	● 60.57.02.02	1/8	1/8	21 ¹⁾	26 ¹⁾	6.3	11 ¹⁾	14	350
-	-	● 60.57.04.02	1/4	1/8	27	30	6.3	14	14	350
-	-	● 60.57.04.04	1/4	1/4	27	32	9.5	14	19	350
-	-	● 60.57.06.04	3/8	1/4	29	33.5	9.5	19	19	350
-	-	● 60.57.06.06	3/8	3/8	29	37	9.5	19	22	350
-	-	● 60.57.06.08	3/8	1/2	35	43	13.0	22	27	200
-	-	● 60.57.08.06	1/2	3/8	35	39.5	9.5	22	22	200
-	-	● 60.57.08.08	1/2	1/2	35	43	13.0	22	27	200
-	-	● 60.57.12.08	3/4	1/2	43	45.5	13.0	27	27	200
-	-	● 60.57.12.12	3/4	3/4	43	49.5	13.0	27	36	200
-	-	● 60.57.16.12	1"	3/4	45.5	50.5	13.0	33	36	120
-	-	● 60.57.16.16	1"	1"	45.5	52.5	16.0	33	41	120
-	-	● 60.57.20.16	1"1/4	1"	52	57	16.0	41	41	105
-	-	● 60.57.20.20	1"1/4	1"1/4	52	57	16.0	41	50	105
-	-	● 60.57.24.20	1"1/2	1"1/4	59	60.5	16.0	48	50	105
-	-	● 60.57.24.24	1" 1/2	1"1/2	59	60.5	16.0	48	55	105

1) AISI 316L CH = 14 B = 25 B2 = 29



“T” DERIVAZIONE CON DADO GIREVOLE
“T” DE DERIVATION ECROU PIVOTANT
DERIVATING “T” WITH ROTARY NUT
ABLEITUNG-T MIT DREHMUTTER
TE MACHO TUERCA LOCA LATERAL

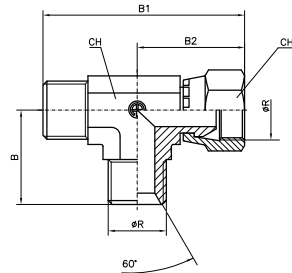

Ø TUBO-TUBE-ROHR		CODICE REFERENCE CODE BEST.-NR. REFERENCIA	Ø R BSPP	B	B1	B2	CH	CH1	PN
mm.	Poll.- Pouces Inch.- Zoll Pulgadas								
-	-	● 60. 59.02.02	1/8	17 ¹⁾	39 ¹⁾	22	11 ¹⁾	14	350
-	-	● 60. 59.04.04	1/4	27	53	26	14	19	350
-	-	● 60. 59.06.06	3/8	29	60	31	19	22	350
-	-	● 60. 59.08.08	1/2	35	71	36	22	27	200
-	-	● 60. 59.10.10	5/8	38	78	40	27	28/30 ²⁾	200
-	-	● 60. 59.12.12	3/4	43	83	40	27	32	200
-	-	● 60. 59.16.16	1"	45,5	98,5	53	33	38	120
-	-	● 60. 59.20.20	1" 1/4	52 ³⁾	110 ³⁾	58	41	50	105
-	-	● 60. 59.24.24	1" 1/2	59 ⁴⁾	127,5 ⁴⁾	68,5	48 ⁴⁾	55	105

1) AISI 316L CH = 14 B = 27 B1 = 54
3) AISI 316L B = 53,5 B1 = 111,5

2) AISI 316L CH = 30
4) AISI 316L CH = 50 B = 62,5 B1 = 131

UNIONE A “T” CON DADO GIREVOLE
UNION “T” ECROU PIVOTANT
EQUAL TEES WITH ROTARY NUT
T-VERSCHRAUBUNG MIT DREHMUTTER
UNION TE CON TUERCA LOCA

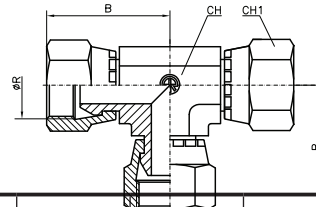

Ø TUBO-TUBE-ROHR		CODICE REFERENCE CODE BEST.-NR. REFERENCIA	Ø R BSPP	B	CH	CH1	PN
mm.	Poll.- Pouces Inch.- Zoll Pulgadas						
-	-	● 60. 60.02.02	1/8	22 ¹⁾	11 ¹⁾	14	350
-	-	● 60. 60.04.04	1/4	27,2	14	19	350
-	-	● 60. 60.06.06	3/8	32,3	19	22	350
-	-	● 60. 60.08.08	1/2	36,4	22	27	200
-	-	● 60. 60.10.10	5/8	38	27	28 ²⁾	200
-	-	● 60. 60.12.12	3/4	42,5	27	32	200
-	-	● 60. 60.16.16	1"	53	33	38	120
-	-	● 60. 60.20.20	1" 1/4	58	41	50	105
-	-	● 60. 60.24.24	1" 1/2	68,5	48 ³⁾	55	105

1) AISI 316L CH = 14 B = 26,7
3) AISI 316L CH = 50

2) AISI 316L CH = 30

“T” FEMMINA NPT
“T” FEMELLE NPT
FEMALE “T” NPT
AUFSCHRAUB-T NPT
TE HEMBRA NPT

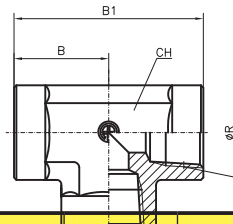

Ø TUBO-TUBE-ROHR		CODICE REFERENCE CODE BEST.-NR. REFERENCIA	Ø R NPT	B	B1	CH	PN
mm.	Poll.- Pouces Inch.- Zoll Pulgadas						
-	-	● 60. 64.02.02	1/8	16,8	33,6	14	350
-	-	● 60. 64.04.04	1/4	22,4	44,8	19	350
-	-	● 60. 64.06.06	3/8	25,9	51,8	22	315
-	-	● 60. 64.08.08	1/2	31,2	62,4	27	210
-	-	● 60. 64.12.12	3/4	34,5	69	33	210
-	-	● 60. 64.16.16	1"	41,4	82,8	41	120
-	-	● 60. 64.20.20	1" 1/4	43,2	86,4	48	105
-	-	● 60. 64.24.24	1" 1/2	62	105,6	64	105



"T" FEMMINA BSPP
"T" FEMELLE BSPP
FEMALE "T" BSPP
AUFSCHRAUB-T BSPP
TE HEMBRA BSPP

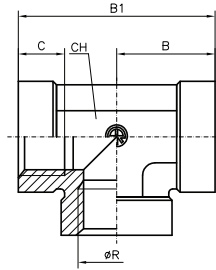

Ø TUBO-TUBE-ROHR		CODICE REFERENCE CODE BEST.-NR. REFERENCIA	Ø R BSPP	B	B1	C	CH	PN
mm.	Poll.- Pouces Inch.- Zoll Pulgadas							
-	-	● 60. 65.02.02	1/8	16,8	33,6	9	14	350
-	-	● 60. 65.04.04	1/4	23	46	13	19	350
-	-	● 60. 65.06.06	3/8	26	52	13	22	315
-	-	● 60. 65.08.08	1/2	31	62	15	27	210
-	-	● 60. 65.12.12	3/4	36	72	17	33	210
-	-	● 60. 65.16.16	1"	42,5	85	20	41	120
-	-	● 60. 65.20.20	1" 1/4	58,5	117	22	48	105
-	-	● 60. 65.24.24	1" 1/2	62	122	24	64	105

"T" DI DERIVAZIONE MASCHIO/FEMMINA NPT
"T" MALE/FEMELLE DE DERIVATION NPT
DERIVATING "T" MALE/FEMALE NPT
ABLEITUNG "T" - NPT
TE MACHO/HEMBRA DERIVACION NPT

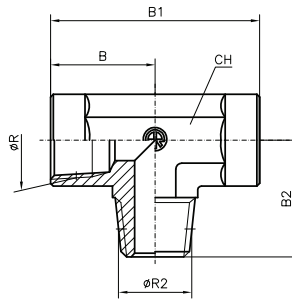

Ø TUBO-TUBE-ROHR		CODICE REFERENCE CODE BEST.-NR. REFERENCIA	Ø R NPT	Ø R2 NPT	B	B1	B2	CH	PN
mm.	Poll.- Pouces Inch.- Zoll Pulgadas								
-	-	● 60. 67.02.02	1/8	1/8	16,8	33,6	19,8	14	350
-	-	● 60. 67.04.04	1/4	1/4	22,4	44,8	27,7	19	350
-	-	● 60. 67.06.06	3/8	3/8	25,9	51,8	31	22	315
-	-	● 60. 67.08.08	1/2	1/2	31,2	62,4	37,3	27	210
-	-	● 60. 67.12.12	3/4	3/4	34,5	69	40,4	33	210
-	-	● 60. 67.16.16	1"	1"	41,4	82,8	50	41	120
-	-	● 60. 67.20.20	1" 1/4	1" 1/4	43,2	86,4	60,5	48	105
-	-	● 60. 67.24.24	1" 1/2	1" 1/2	62	124	67,1	64	105

"L" DI DERIVAZIONE MASCHIO/FEMMINA NPT
"L" MALE/FEMELLE DE DERIVATION NPT
DERIVATING "L" MALE/FEMALE NPT
ABLEITUNG "L" - NPT
TE MACHO/HEMBRA DERIVACION NPT

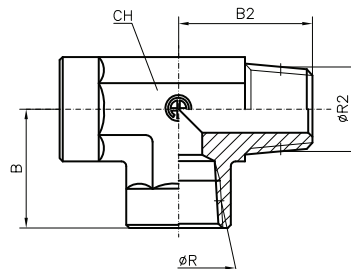

Ø TUBO-TUBE-ROHR		CODICE REFERENCE CODE BEST.-NR. REFERENCIA	Ø R NPT	Ø R2 NPT	B	B2	CH	PN
mm.	Poll.- Pouces Inch.- Zoll Pulgadas							
-	-	● 60. 68.02.02	1/8	1/8	16,8	19,8	14	350
-	-	● 60. 68.04.04	1/4	1/4	22,4	27,7	19	350
-	-	● 60. 68.06.06	3/8	3/8	25,9	31	22	315
-	-	● 60. 68.08.08	1/2	1/2	31,2	37,3	27	210
-	-	● 60. 68.12.12	3/4	3/4	34,5	40,4	33	210
-	-	● 60. 68.16.16	1"	1"	41,4	50	41	120
-	-	● 60. 68.20.20	1" 1/4	1" 1/4	43,2	60,5	48	105
-	-	● 60. 68.24.24	1" 1/2	1" 1/2	52,8	67,1	64	105



"T" DI DERIVAZIONE MASCHIO BSPT FEMMINA BSPP
 "T" MALE BSPT FEMELLE BSPP DE DERIVATION
 DERIVATING "T" MALE BSPT FEMALE BSPP
 ABLEITUNG "T" - BSPT/BSPP
 TE MACHO BSPT HEMBRA BSPP DERIVACION

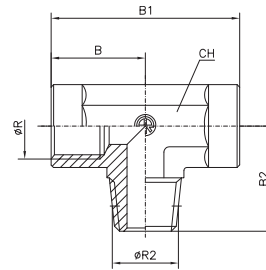

Ø TUBO-TUBE-ROHR		CODICE REFERENCE CODE BEST.-NR. REFERENCIA	Ø R BSPP	Ø R2 BSPT	B	B1	B2	CH	PN
mm.	Poll.- Pouces Inch.- Zoll Pulgadas								
-	-	● 60. 77.02.02	1/8	1/8	16,8	33,6	19,8	14	350
-	-	● 60. 77.04.04	1/4	1/4	22,4	44,8	27,7	19	350
-	-	● 60. 77.06.06	3/8	3/8	25,9	51,8	31	22	315
-	-	● 60. 77.08.08	1/2	1/2	31,2	62,4	37,3	27	210
-	-	● 60. 77.12.12	3/4	3/4	34,5	69	40,4	33	210
-	-	● 60. 77.16.16	1"	1"	41,4	82,8	50	41	120
-	-	● 60. 77.20.20	1" 1/4	1" 1/4	58,5	117	59,6	48	105
-	-	● 60. 77.24.24	1" 1/2	1" 1/2	62	124	67,1	64	105

"L" DI DERIVAZIONE MASCHIO BSPT FEMMINA BSPP
 "L" MALE BSPT FEMELLE BSPP DE DERIVATION
 DERIVATING "L" MALE BSPT FEMALE BSPP
 ABLEITUNG "L" - BSPT/BSPP
 "L" MACHO BSPT HEMBRA BSPP DERIVACION

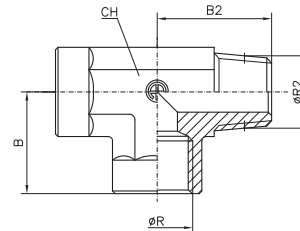

Ø TUBO-TUBE-ROHR		CODICE REFERENCE CODE BEST.-NR. REFERENCIA	Ø R BSPP	Ø R2 BSPT	B	B2	CH	PN
mm.	Poll.- Pouces Inch.- Zoll Pulgadas							
-	-	● 60. 78.02.02	1/8	1/8	16,8	19,8	14	350
-	-	● 60. 78.04.04	1/4	1/4	22,4	27,7	19	350
-	-	● 60. 78.06.06	3/8	3/8	25,9	31	22	315
-	-	● 60. 78.08.08	1/2	1/2	31,2	37,3	27	210
-	-	● 60. 78.12.12	3/4	3/4	34,5	40,4	33	210
-	-	● 60. 78.16.16	1"	1"	41,4	50	41	120
-	-	● 60. 78.20.20	1" 1/4	1" 1/4	43,2	60,5	48	105
-	-	● 60. 78.24.24	1" 1/2	1" 1/2	62	67,1	64	105

CROCE FEMMINA BSPP
 CROIX FEMELLE BSPP
 FEMALE CROSS BSPP
 KREUZ BSPP
 CRUZ HEMBRA BSPP

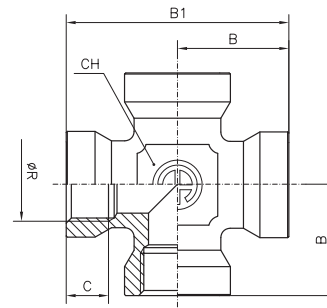

Ø TUBO-TUBE-ROHR		CODICE REFERENCE CODE BEST.-NR. REFERENCIA	Ø R BSPP	B	B1	C	CH	PN
mm.	Poll.- Pouces Inch.- Zoll Pulgadas							
-	-	● 60. 99.02.02	1/8	29	58	9	17	350
-	-	● 60. 99.04.04	1/4	31	62	13	19	350
-	-	● 60. 99.06.06	3/8	33,5	67	13	24	250
-	-	● 60. 99.08.08	1/2	38	76	15	27	225
-	-	● 60. 99.12.12	3/4	43,5	87	17	36	200
-	-	● 60. 99.16.16	1"	50	100	19	41	160
-	-	● 60. 99.20.20	1" 1/4	59	118	22	50	160



UNIONE GOMITO 90° BSPP/BSPT
UNION COUDE 90° BSPP/BSPT
ELBOW COUPLING 90° BSPP/BSPT
WINKELVERSCHRAUBUNG 90° BSPP/BSPT
UNION CODO 90° BSPP/BSPT

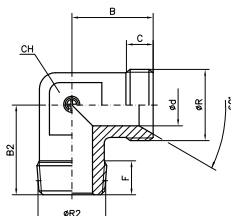

Ø TUBO-TUBE-ROHR		CODICE REFERENCE CODE BEST.-NR. REFERENCIA	Ø R BSPP	Ø R2 BSPT	B	C	F	Ø d	CH	B2	PN
mm.	Poll.- Pouces Inch.- Zoll Pulgadas										
-	-	● TN155 - 1/8	1/8	1/8	21	10,5	13	4	11	19,8	350
-	-	● TN155 - 1/4	1/4	1/4	24,5	11,5	14	6	14	27	350
-	-	● TN155 - 3/8	3/8	3/8	29	12,5	15,5	9	17	30,5	350
-	-	● TN155 - 1/2	1/2	1/2	30,5	13	17,5	11	19	35	200
-	-	● TN155 - 3/4	3/4	3/4	37	14	18,5	16	27	42	200
-	-	● TN155 - 1"	1"	1"	43,5	17	20	21	36	47,5	120
-	-	● TN155 - 1" 1/4	1" 1/4	1" 1/4	50	19	23	26	41	54	105
-	-	● TN155 - 1" 1/2	1" 1/2	1" 1/2	58,5	23	23	32	50	62	105

● Disponibile fino ad esaurimento - Verfügar nur solange vorrätig - Available while stocks last - Disponible jusqu'a epuisement de notre stock -
Disponible mientras haya existencias
Sostituito da 60.02 - Von 60.02 ersetzt - Replaced by 60.02 - Remplace par 60.02 - Sostituido por 60.02

UNIONE A "T"
UNION A "T"
EQUAL TEES
T-VERSCHRAUBUNG
UNION TE MACHO-MACHO

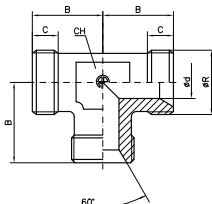

Ø TUBO-TUBE-ROHR		CODICE REFERENCE CODE BEST.-NR. REFERENCIA	Ø R BSPP	B	C	Ø d	CH	PN
mm.	Poll.- Pouces Inch.- Zoll Pulgadas							
-	-	● TN164 - 1/4	1/4	24,5	11,5	6	14	350
-	-	● TN164 - 3/8	3/8	29	12,5	9	17	350
-	-	● TN164 - 1/2	1/2	30,5	13	11	19	200
-	-	● TN164 - 3/4	3/4	37	14	16	27	200
-	-	● TN164 - 1"	1"	43,5	17	21	36	120
-	-	● TN164 - 1" 1/4	1" 1/4	50	19	26	41	105
-	-	● TN164 - 1" 1/2	1" 1/2	58,5	23	32	50	105

● Disponibile fino ad esaurimento - Verfügar nur solange vorrätig - Available while stocks last - Disponible jusqu'a epuisement de notre stock -
Disponible mientras haya existencias
Sostituito da 60.51 - Von 60.51 ersetzt - Replaced by 60.51 - Remplace par 60.51 - Sostituido por 60.51

UNIONE GOMITO 90°
UNION CODE 90°
ELBOW COUPLING 90°
WINKELVERSCHRAUBUNG 90°
UNION CODO MACHO 90°

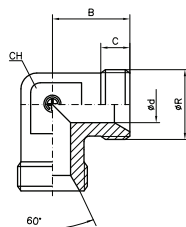

Ø TUBO-TUBE-ROHR		CODICE REFERENCE CODE BEST.-NR. REFERENCIA	Ø R BSPP	B	C	Ø d	CH	PN
mm.	Poll.- Pouces Inch.- Zoll Pulgadas							
-	-	● TN166 - 1/4	1/4	24,5	11,5	6	14	350
-	-	● TN166 - 3/8	3/8	29	12,5	9	17	350
-	-	● TN166 - 1/2	1/2	30,5	13	11	19	200
-	-	● TN166 - 3/4	3/4	37	14	16	27	200
-	-	● TN166 - 1"	1"	43,5	17	21	36	120
-	-	● TN166 - 1" 1/4	1" 1/4	50	19	26	41	105
-	-	● TN166 - 1" 1/2	1" 1/2	58,5	23	32	50	105

● Disponibile fino ad esaurimento - Verfügar nur solange vorrätig - Available while stocks last - Disponible jusqu'a epuisement de notre stock -
Disponible mientras haya existencias
Sostituito da 60.01 - Von 60.01 ersetzt - Replaced by 60.01 - Remplace par 60.01 - Sostituido por 60.01



RESPONSABILITÀ PRODOTTI

La nostra ditta è assicurata da una Polizza di Responsabilità Prodotti per qualsiasi importo, disastri compresi. La legge D.P.R. 224/88 CE/85-374 dice però che "la Responsabilità" sarà imputata alla parte che risulterà essere stata negligente. Il rivenditore a sua volta ha la responsabilità di accertarsi se il cliente sa come deve essere impiegato il prodotto fornendo il catalogo tecnico-commerciale al momento della vendita. L'utente è responsabile se, pur in possesso delle istruzioni di come impiegare il prodotto, non le rispetta, credendole superflue per sua convinzione o superficialità. Quindi la legge prevede che ciascuna delle parti ne prenda responsabilità perché è conveniente per tutti collaborare per evitare casi o disastri. I diritti di garanzia dell'utilizzatore sono validi solo se vengono rispettate tutte le prescrizioni riportate sui Cat. Rastelli. Il mancato rispetto delle stesse può pregiudicare la sicurezza funzionale del prodotto e causare la perdita dei diritti di garanzia.

PRODUKTHAFTPFLICHT

Unsere Firma ist durch eine Produkthaftpflichtpolice für jeglichen Betrag, Unfälle inbegriffen, versichert. Nach dem Gesetz D.P.R. 224/88 EG/85-374 haftet jedoch die Partei, die erwiesenermaßen nachlässig war. Das Produkt kann verantwortlich gemacht werden, wenn der Schaden durch seine Mängel verursacht wurde. Der Verkäufer trägt seinerseits die Verantwortung, sich zu vergewissern, daß der Kunde darüber unterrichtet ist, wie das Produkt einzusetzen ist. Der Anwender haftet, falls er, obwohl in Besitz der Gebrauchsanweisung, sie nicht berücksichtigt, weil er sie aus eigener Überzeugung oder Oberflächlichkeit für überflüssig hält. Das Gesetz sieht vor, daß jede Partei die Verantwortung übernimmt, denn die Zusammenarbeit um Zwischenfälle Oder Unfälle zu vermeiden ist für alle von Vorteil. Die Gewährleistungen können vom Benutzer nur dann in Anspruch genommen werden, wenn alle in den Rastelli-Katalogen enthaltenen Hinweise beobachtet worden sind. Das Versäumnis, das zu tun, kann die Funktionssicherheit des Produktes beeinträchtigen und die Ungültigkeit der Gewährleistungsansprüche verursachen.

LIABILITY FOR PRODUCTS

Our company is insured, for an unlimited figure, by a Policy of Liability for Products, which also covers accidents. The law D.P.R. 224/88 CE/85-374, however, states that "liability" will be attributed to the party which proves to have been negligent. The product is liable if the damage caused proves to be due to a defect in the product itself. The retailer, in turn, is responsible for ascertaining whether his customer is fully aware of how the product should be used giving the commercial technical catalogue in force at the moment of the sale. The user is liable if, despite being in possession of instructions relating to use of the product, he fails to follow these instructions, believing them to be merely a superfluous formality. The law, therefore, prescribes that both parties should accept their due measure of responsibility, as it is better that everyone should make a concerted effort to avoid cases or accidents of this nature. The guarantee rights can be claimed by the user only if all the instructions contained in the RASTELLI Catalogues have been observed. A failure to observe them may impair the functional safety of the product and implicate the loss of the guarantee rights.

RESPONSABILITE PRODUITS

En cas de sinistre notre Société est assurée par une police d'assurance "responsabilité produits" a montant illimité. La loi D.P.R. 224/88 CE/85-374 précise que la responsabilité sera imputée à la partie qui se révélera avoir été négligente. Le produit sera mis en cause si le dommage est du à un défaut de fabrication. Tout utilisateur devra avoir pris connaissance de la notice de montage et de la capacité d'utilisation de nos produits en foumissant du catalogue technique en vigueur au moment de la vente. Dans le cas contraire, l'utilisateur sera tenu pour responsable des risques encourus. La loi prévoit que chacune des parties assume ses responsabilités étant recommandé à tous de collaborer afin d'éviter tout dommage. Des notices d'utilisation de nos produits sont à votre disposition. Les droits de garantie de l'utilisateur ne sont valables que si l'on a observé toutes les prescriptions contenues dans les Catalogues de RASTELLI. Leur inobservance peut compromettre la sécurité fonctionnelle du produit et causer la perte des droits de garantie.

RESPONSABILIDAD DE LOS PRODUCTOS

Nuestra sociedad está asegurada mediante una Póliza de Responsabilidad de los Productos, por cualquier importe, incluyendo posibles desastres. Sin embargo, la ley D.P.R. 224/88 CE/85-374 dice que "la Responsabilidad" se imputará a la parte culpable de negligencia. A su vez, le corresponde al agente revendedor la responsabilidad de cerciorarse de que el cliente sabe cómo tiene que emplear el producto suministrando el catalogo técnico y comercial en uso en el momento de la venta. El usuario será responsable de los posibles daños si, aun conociendo las instrucciones para el uso correcto del producto, no las respeta considerándolas - por propia convicción o superficialidad - superfluas. La ley prevé, entonces, que cada parte asuma su responsabilidad, siendo conveniente para todos colaborar para prevenir todo tipo de accidente. Los derechos que la garantía otorga al usuario valen sólo si se respetan todas las instrucciones que se dan en los Catálogos Rastelli. El incumplimiento de dichas instrucciones puede comprometer la seguridad de funcionamiento del producto y provocar la pérdida de los derechos de garantía.

Le quote ed i dati tecnici riportati in questo catalogo tecnico commerciale sono soltanto a titolo indicativi. La RASTELLI RACCORDI si riserva il diritto di apportare variazioni tecniche, dimensionali ed estetiche ai propri prodotti senza preavviso. Il presente catalogo annulla e sostituisce tutti i precedenti. Testi originali in lingua italiana che fanno testo in caso di differenze interpretative con le versioni estere

Die in den Katalogtabellen angegebenen Maße und Gewichte verstehen sich als hinweisend. RASTELLI RACCORDI behält sich das Recht vor, Änderungen der technischen Eigenschaften, der Abmessungen und der ästhetischen Gestaltung ihrer Produkte vorzunehmen. Dieser Katalog annulliert und ersetzt alle vorherigen. Es gelten die Originaltexte in italienischer Sprache im Falle von Interpretationsunterschieden mit den Versionen in anderen Sprachen.

The figures and technical data set out in the tables in this catalogue are only intended as approximations. RASTELLI RACCORDI reserves the right to make any technical or dimensional variations to its products, or change their appearance, in any way they deem fit without notice. The present catalogue revokes and replaces all former ones. The original texts in italian are authoritative in case of any interpretative differences with the versions in other languages

Les cotes et données techniques reportés dans les tableaux de ce catalogue sont purement indicatifs. La Société RASTELLI RACCORDI se réserve le droit d'apporter des variations techniques, dimensionnelles et esthétiques à ses propres produits sans preavis. Ce catalogue de vente technique annule et remplace toutes les versions précédentes. En cas de divergences ou litiges, les textes originaux en langue italienne seront considérés comme valides et prédominants sur les traductions étrangères.

Las cotas y datos técnicos que se leen en tablas del presente catálogo tienen carácter indicativo. La sociedad RASTELLI RACCORDI se reserva el derecho de efectuar en sus productos toda variación técnica, dimensional o estética que considere necesaria sin previo aviso. El catalogo corriente adroga y reemplaza todos los antecedentes. Los textos en italiano son los que tienen que ser considerados en caso de una interpretación an las versiones en otros idiomas.

- CI RISERVIAMO A TERMINI DI LEGGE LA PROPRIETÀ DI QUESTO CATALOGO CON DIVIETO DI RIPRODURLO E/O COPIARLO SENZA LA NOSTRA AUTORIZZAZIONE.
- WIR BEHALTEN UNS DAS RECHTLICHE EIGENTUM DIESES KATALOGES VOR DAS NACHDRUCKEN UND KOPIEREN DESSELBEN OHNE UNSERE GENEHMIGUNG IST NICHT GESTATTET.
- WE RESERVE THE RIGHT TO OWNERSHIP OF THIS CATALOGUE IN ACCORDANCE WITH THE LAW, REPRODUCTION AND/OR COPIES ARE STRICTLY PROHIBITED WITHOUT OUR PRIOR AUTHORISATION.
- DROITS DE REPRODUCTION RESERVES POUR TOUT PAYS. TOUTE REPRODUCTION, TOTALE OU PARTIELLE, EST INTERDITE SAUF ACCORDS PREALABLE DE LA SOCIETE RASTELLI RACCORDI SRL.
- RESERVADOS TODOS LOS DERECHOS. PROHIBIDA LA REPRODUCCIÓN TOTAL O PARCIAL SIN AUTORIZACIÓN EXPRESA.



TN 285A

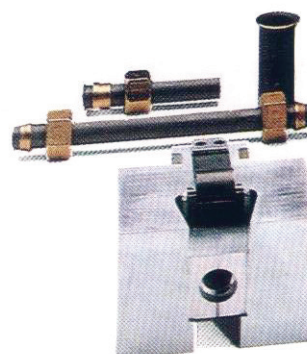

FUNZIONAMENTO IDRAULICO
HYDRAULIKBETRIEB
HYDRAULIC WORKING
FONCTIONNEMENT HYDRAULIQUE
FUNCIONAMIENTO HIDRÁULICO

Attrezzature per il premontaggio degli anelli dei raccordi DIN 2353
Attrezzature per la svasatura a 37° dei tubi d'acciaio

Vorrichtungen zur Vormontage von Schneidringen auf
Verschraubungen nach DIN 2353
Vorrichtungen zum Spitzsenken von Stahlrohren auf 37°

Tools for the pre-fitting of the cutting rings for DIN 2353 fittings
Tools for flaring of steel tubes at 37°

Appareils pour le prémontage des bagues des raccords DIN 2353
Appareils pour l'évasement à 37° des tubes en acier

Equipo para el premontaje de las ojivas de los racores DIN 2353
Equipo para el avellanado en 37° de los tubos de acero



Finitura superficiale dei raccordi in acciaio al carbonio

ZINCATURA BIANCA

Raccordi con zincatura trivalente più fissaggio pellicolare, lubrificante, ecologica, resistenza alla nebbia salina: oltre 400 ore.
(Riferimento Legge Europea 2000/53CE del 18.9.2000).

La Rastelli Raccordi, probabilmente unica casa produttrice di raccordi ad avere nelle proprie officine di produzione impianti di zincatura, ha messo a punto in omaggio alla legge in oggetto, il trattamento sopra descritto.

Ricordiamo che questo trattamento elimina il cromo esavalente, notoriamente pericoloso all'uomo e all'ambiente, inserendo il raccordo Rastelli tra i prodotti ecologici, cioè NON NOCIVI.

Oberflächenbehandlung der Stahlschlußstücke

WEISSE VERZINKUNG

Rohrverschraubungen mit der schmierenden, umweltfreundlichen Chrom³ - Verzinkung plus Filmfixierung, Salznebelwiderstand: über 400 Stunden.
(nach dem EU Gesetz 2000/53 EG vom 18.9.2000).

Rastelli Raccordi, wahrscheinlich der einzige Rohrverschraubungen-Hersteller mit Verzinkungsanlagen in den eigenen Werken, verfügt nun, dem o. g. Gesetz entsprechend, auch über die oben beschriebene Oberflächenbehandlung.

Wir weisen darauf hin, dass für Menschen und Umwelt bekanntlich schädliche Chrom⁶ bei dieser Behandlung ausgeschlossen wird, dadurch zählen die Rastelli Verschraubungen zu den Ökologischen, d. h. UNSCHÄDLICHEN Produkten.

Surface finishes for steel couplings

WHITE GALVANIZATION

Fittings with trivalent galvanization, plus film fixing, lubricant, ecological, resistance to salty mist: over 400 hours.
(Ref.: European law 2000/53 EC of 18.9.2000).

Rastelli Raccordi, probably the only fitting manufacturing company which has also galvanizing equipments installed in its production plants, has adopted - in compliance with the law - the above described treatment.

We should like to underline that this treatment eliminates hexavalent chrome, notoriously dangerous to man and environment, thus putting the Rastelli fittings in the class of ecological products, that is NON-NOXIOUS products.



Finitions superficielles des raccords en acier

ZINGAGE BLANC

Raccords à zingage trivalent plus fixage pelliculaire, lubrifiant, écologique, résistance à la brume saline: plus de 400 heures.

(Réf.: Loi européenne 2000/53 EC du 18.9.2000).

Rastelli Raccordi, probablement la seule maison productrice de raccords qui a, dans ses usines, des installations de zingage des produits, a mis a point - en conformité avec la loi susmentionnée - le traitement décrit plus haut.

On souligne que ce traitement élimine le chrome hexavalent, notoirement dangereux pour l'homme et l'environnement, en mettant ainsi les raccords Rastelli parmi les produits écologiques, c'est -à-dire NON-NOCIFS.

Acabado superficial de los racoreas de acero

CINCADO BLANCO

Racores de cincado trivalente, màs fijaciòn a modo do pelicula, lubrificante, ecològico, resistencia a la bruma salina: màs de 400 horas.

(Ref: Ley europea 2000/53 EG del 18.9.2000).

Rastelli Raccordi, la unica empresa productoria de racores que tiene en sus fàbricas equipos de cincado, a puesto recentemente a punto de conformidad con la mencionada ley, el tratamiento arriba descrito.

Recordamos que este tratamiento elimina el cromo hexavalente, que como es sabido, es peligroso para el hombre y el medio ambiente, situando asi los racores Rastelli entre los productos ecològicos, es decir no NOCIVOS.



PRODOTTI - PRODUKTE - PRODUCTS - PRODUITS - PRODUCTOS

DIN 2353 - ISO 8434-1

RACCORDI AD ANELLO PER ALTE PRESTAZIONI
 HOCHDRUCK - ROHRVERSCHRAUBUNGEN
 RING FITTINGS FOR HIGH PRESSURES
 RACCORDS A BAGUE POUR PRESSIONS ELEVÉES
 RACORES DE ANILLO PARA ALTAS PRESIONES

ACCIAIO AL CARBONIO - ACCIAIO INOX
 KOHLENSTOFF STAHL EDELSTAHL
 CARBON STEEL - STAINLESS STEEL
 ACIER AU CARBONE ACIER INOX
 ACERO AL CARBONO ACERO INOXIDABLE

RINA
CERTIFICAZIONE ISO 9001

Facilità di montaggio
Tenuta assoluta
Nessuna saldatura
Esecuzione perfetta

Leichte Montage
Absolute Dichte
Kein Schweißen
Perfekte Ausführung

Easy mounting
Perfect tight
No welding
Excellent manufacture

Montage aise
Étanchéité absolue
Pas de soudures
Fabrication parfaite

RASTELLI RACCORDI - s.r.l.
27019 VILLANTERIO (PV) - ITALIA
Tel. (+39) 0382 963000 fax (+39) 0382 967007 Fax (+39) 0382 967080 - 962110
e-mail: marketing@rastelliaccordi.it web: www.rastelliaccordi.com
e-mail: administration@rastelliaccordi.it

RACCORDI A TENUTA MORBIDA
 VERSCHRAUBUNGEN MIT WEICHER DICHTUNG
 FITTINGS WITH SUPPLE PACKING
 RACCORDS A JOINT SOUPLE
 RACORES DE CIERRE ESTANCO

AR3/C ANELLO DI SERRAGGIO
A TENUTA ERMETICA PER
RACCORDI DIN 2353
(ISO 8434-1)

RASTELLI RACCORDI - s.r.l.
27019 VILLANTERIO (PV) - ITALIA
Tel. (+39) 0382 963000 fax (+39) 0382 967007 Fax (+39) 0382 967080 - 962110
e-mail: marketing@rastelliaccordi.com

ACCIAIO AL CARBONIO - ACCIAIO INOX
 KOHLENSTOFF STAHL - EDELSTAHL
 CARBON STEEL - STAINLESS STEEL
 ACIER AU CARBONE - ACIER INOX
 ACERO AL CARBONO - ACERO INOXIDABLE

DIN 2353 - ISO 8434-1 - AR3/C

B.S. - SAE - DIN - NF STANDARD

ACCIAIO AL CARBONIO
 KOHLENSTOFF STAHL
 CARBON STEEL
 ACIER AU CARBONE
 ACERO AL CARBONO

RACCORDI TUBO FLESSIBILE
 SCHLAUCHMATUREN
 FLEXIBLE TUBE FITTINGS
 EMBOUT DE FLEXIBLES
 RACOR PARA TUBO FLEXIBLE

RACCORDI TUBO FLESSIBILE
 SCHLAUCHMATUREN
 FLEXIBLE TUBE FITTINGS
 EMBOUTS DE FLEXIBLES
 RACOR PARA TUBO FLEXIBLE

RASTELLI RACCORDI - s.r.l.
27019 VILLANTERIO (PV) - ITALIA
Tel. (+39) 0382 963000 fax (+39) 0382 967007 Fax (+39) 0382 967080 - 962110
web: www.rastelliaccordi.com e-mail: marketing@rastelliaccordi.com

RACCORDI AD ANELLO PER TUBI GAS
 ROHRVERSCHRAUBUNGEN (FR. REIHE GAZ)
 RING FITTINGS (GAZ TYPE)
 RACCORDS A BAGUE POUR TUBES GAZ
 RACORES DE ANILLO PARA TUBOS GAZ

RACCORDI AD ANELLO PER TUBI GAS
 RACCORDS A BAGUE POUR TUBES GAZ

Facilità di montaggio
tenuta assoluta
nessuna saldatura
esecuzione perfetta

montage aise
étanchéité absolue
pas de soudures
fabrication parfaite

RASTELLI RACCORDI - s.r.l.
27019 VILLANTERIO (PV) - ITALIA
Tel. (+39) 0382 963000 fax (+39) 0382 967007 Fax (+39) 0382 967080 - 962110
web: www.rastelliaccordi.com e-mail: marketing@rastelliaccordi.com

ACCIAIO AL CARBONIO
 KOHLENSTOFF STAHL
 CARBON STEEL
 ACIER AU CARBONE
 ACERO AL CARBONO

NF STANDARD

- Gli articoli su fondo colorato sono disponibili su richiesta con consegna da pronta a 60 giorni.
Prezzo: escluso dallo sconto massimo.
- Les articles sur fond coloré sont disponibles sur demande avec livraison d'immédiate jusqu'à 60 jours.
Prix: exclus de l'escompte maximum.
- The articles on a coloured background are available on request with prompt to 60-days delivery.
Price: excluded from maximum discount.
- Die Artikel auf buntem Hintergrund stehen zur Verfügung mit sofortiger bis 60-Tage Lieferzeit.
Preis: ausgeschlossen vom Höchststrabatt.
- Los artículos sobre fondo en color están disponibles a petición con entrega de pronta hasta 60 días.
Precio: excluidos del descuento máximo.

